

## A PUSH PULL ELECTROMETER-VALVE POTENTIOMETER

*By C T Abichandan and S K K Jathar*

The glass electrode in recent years is rapidly replacing the hydrogen and quinhydrone electrodes in pH measurements because it reaches equilibrium in a very short time and does not get poisoned. It is not affected by oxidising or reducing agents and is applicable over a wide range of pH. The only difficulties encountered in the use of a glass electrode are (1) its high electrical resistance, usually of the order of 10–100 megohms, which makes the balancing of the opposite electromotive force from the potentiometer difficult, since the balancing current is reduced to a small value, and (2) the polarization of the electrode due to the continuous drawing of the current, which changes its equilibrium potential. The electrostatic methods such as the use of quadrant electrometer (Mac-Innes and Longworth, *Trans Electrochem Soc*, 1937, **71**, 73) involves many difficulties such as (1) the low voltage sensitivity, (2) temperature fluctuations and (3) lack of zero stability at high sensitivity. The high electrical resistance of the glass electrode can be reduced by decreasing the thickness of the glass membrane and increasing its surface, but these conditions can be satisfied only to a certain limit. All these difficulties can, however, be got rid of by the use of special thermionic valve amplifiers.

The thermionic valves have been used by various workers for measuring the electromotive forces of cells. Goode (*J Amer. Chem Soc*, 1922, **44**, 26, 1925, **47**, 2483) demonstrated that when an unknown electromotive force is placed in the grid circuit of a triode valve, the e.m.f. is determined by the change in anode current. Since the introduction by Goode, of the vacuum tube device for measuring the electromotive force, many battery operated circuits employing this device have been described. In certain cases the single tube circuits have often proved useless due to zero drift and low sensitivity. Dubridge (*Phys. Rev.*, 1931, **37**, 392), Soller (*Rev. Sci. Instruments* 1932, **3**, 416) and Turner and Sieghin (*Ibid*, 1933, **4**, 429) have used a special valve PF 54 and obtained circuits of high

sensitivity. Combining the mu-balance (Turner, *Ibid*, 1933, 4, 665) and conventional bridge circuits, Garman and Diaz (*Ind. Eng. Chem. Anal. Ed*, 1935, 7, 341) have constructed a power operated amplifier, but have not attained any high stability and sensitivity, because of the high line voltage fluctuations. The circuit described by Working (*Ibid*, 1938, 10, 397) is even less sensitive and cannot be used with a glass electrode.

Of the many circuits given by various workers, one described by Morton (*J. Chem. Soc.*, 1931, 2977) is characterized by its zero stability. In this circuit (null ballistic), a high grade condenser is charged with a difference of potential between the potentiometer and the glass electrode. By means of a tapping key this condenser is discharged through a voltage amplifier with a ballistic galvanometer in the circuit of the last stage valve. Hemingway (*Ind. Eng. Chem. Anal. Ed*, 1935, 7, 203) has constructed a direct reading pH meter, depending on the ballistic principle. His instrument when tried was found to be sensitive to about 2 millivolts and hence not suitable for any accurate type of research work.

Mehta and Jatkari (*Proc. Ind. Acad. Sci.*, 1934, 1, 390) have constructed a two stage amplifier, using an electrometer triode in the first stage, and Osram LP<sub>2</sub> valve in the second stage. In this arrangement the drift due to one valve was compensated by drift due to the other. They attained a high sensitivity, but their instrument was not quite free from drifts, and the switch was very complicated, giving an undesirable galvanometer kick due to breaking of the grid circuit.

Many instruments containing an electrometer triode are now on the market, but most of them are quite unsuitable for accurate research work, due to low voltage sensitivity.

One of the most important requirements of an amplifier for use with a glass electrode is that the grid current should be reduced to a minimum. In the ordinary radio tubes a current of the order of  $10^{-9}$  amps flows through the circuit and electromotive force

measured is erroneous by an amount depending on the grid leak used. The valve electrometer used by Mehta and Jatkar is constructed in such a manner that lowest possible grid current ( $10^{-14}$  amps) passes through the system. A sensitive galvanometer cannot, however, be used with this valve, because of its very low mutual conductance and the drift in the anode current. It becomes therefore necessary to couple this valve to another of high mutual conductance to obtain a sufficient voltage sensitivity.

In a thermionic valve circuit the zero drift is of very great consequence, when a series of successive readings are to be taken. It is however not possible to attain a high stability without an accompanying loss of sensitivity, the latter difficulty being overcome by the use of a sensitive mirror galvanometer. The best way to attain zero stability in thermionic valve circuits is to use two identical valves in push-pull. In the present investigation the authors have constructed a two stage amplifier by using two electrometer triodes in push pull in the first stage and two triode valves of high mutual conductance in the second stage. Such an instrument has been used for the measurement of pH and dissociation constants with glass electrode. The circuit diagram of the instrument is given in Fig. 1.

The electrometer triodes (No 4060) supplied by the General Electric Company were considered best suited to minimise the effects caused by the flow of grid current. The electrometer triodes (D) were enclosed in an airtight container, having inside a suitable drying material to prevent leakages over the surface of the tube due to moisture. The connections to the grids of the valves were made through a side tube, insulated with blocks of paraffin. The triodes were operated at 4 volts H.T. potential and the filaments were heated at one volt. The characteristics of the electrometer triodes under operating conditions are given below —

Filament	1.0 Volt.
Anode	.. 1.5 Volts
Grid	.. -2.0 Volts
Filament current	. 0.1 Amp

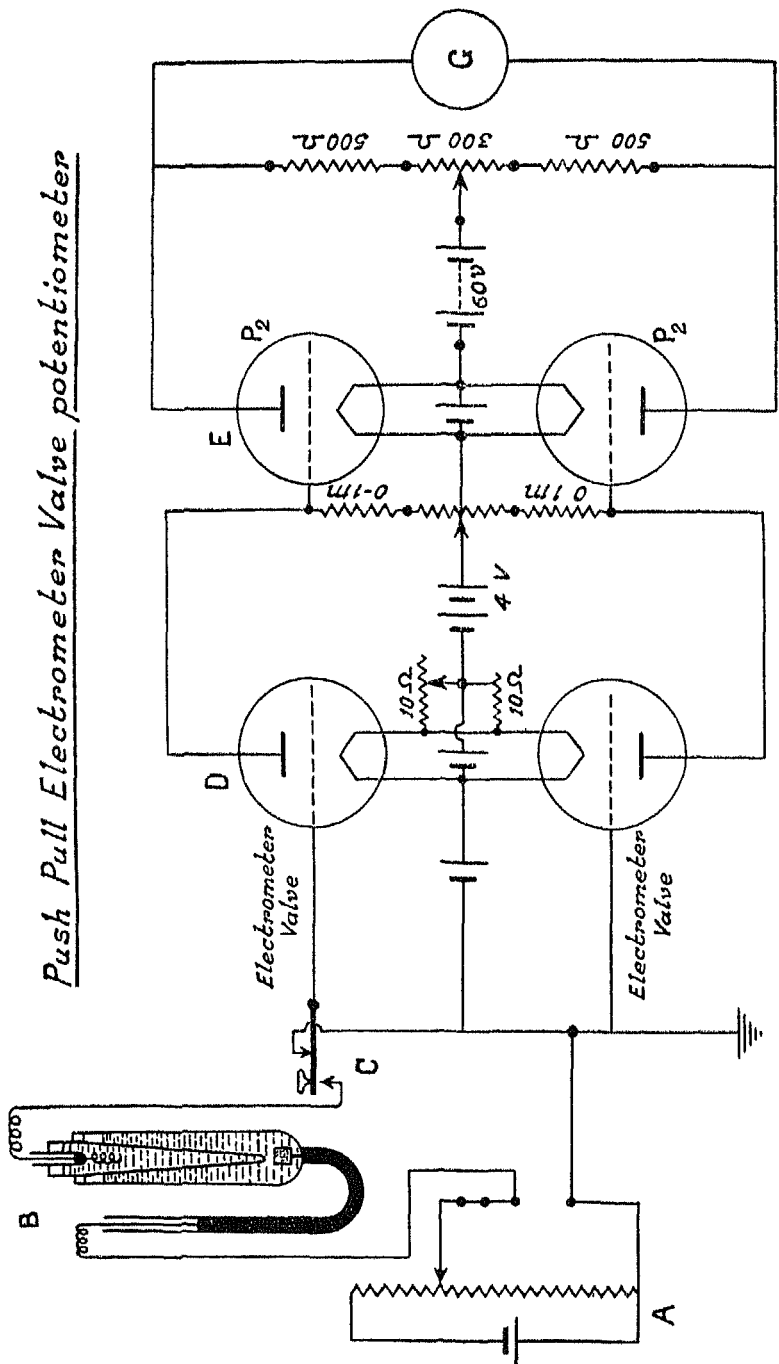

Push Pull Electrometer Valve potentiometer

FIG 1

Mutual conductance	0.001 ma/Volt *
Insulation between grid and electrodes	$10^{16}$ Ohms
Total grid current flowing through the valve	$10^{-14}$ to $10^{-15}$ Amps

A very low plate potential was used for the electrometer valve in order to prevent the increase in the grid current due to photoelectric emission caused by the soft X-rays.

The circuit used for second stage amplification was the same as described by Abichandani and Jatkar (J. Ind. Inst. Sci., 1938, 21A, 363). Two Osram P<sub>2</sub> valves (E, E') having a mutual conductance of 2.0 ma/Volt were used in push-pull. These valves were operated at 50 Volts on the plate and 2 Volts on the filament. The operating conditions were

Filament Voltage	2 Volts
Filament current	0.2 Amp
Anode Voltage	50 Volts
Mutual Conductance	2.0 ma/Volts
Grid Voltage	-2.5 Volts
Plate current	2 millamps

The filaments of the two sets of valves were heated by separate batteries. The electrometer triodes, which were not identical, were matched by regulating the resistance in the filament circuit. Tinsley's Vernier type potentiometer (A) was used for measurements. The galvanometer terminals and the key on the potentiometer were always kept shorted and one of the terminals for the cell was connected to the unknown e.m.f. to be measured, the other being always earthed. The current in the potentiometer was kept steady by floating the supply battery. A unipivot galvanometer (G), having 800 ohms resistance was used as an indicating instrument. Each division of the galvanometer was equal to 0.2 micro-amp. All the valves, resistances and switches were mounted on a paraffined teakwood box.

---

\* Under normal operating condition the mutual conductance of the valve is 0.04 ma/Volt.

and the electrometer key (C) and galvanometer were kept on solid paraffin blocks

The grid of the electrometer valve was connected to the glass electrode (B) through the electrometer key (C), using a highly insulated wire to avoid surface leaks. The key was so adjusted, that the galvanometer needle did not give any kick on pressing and it was possible to use a sensitive mirror galvanometer.

The low mutual conductance of the electrometer valve, owing to the low anode voltage applied, resulted in an overall sensitiveness of 800 microamps per volt, which was found to be quite sufficient for the experiment. One millivolt applied to the grid of the electrometer valve causes a change of 0.004 microamps in the anode current of that valve, so that the potential applied to the second stage is  $(0.004 \times 10^{-6} \times 0.1 \times 10^6)$  0.4 millivolts which in turn will cause a change of 0.8 microamps in the anode of the  $P_2$ , thus resulting in an overall sensitiveness of 0.8 microamps per millivolt. With a plate resistance of 0.5 megohms and 10 volts H.T. in the electrometer valve circuit and 120 volts H.T. on the  $P_2$  valves with a suitable change in grid bias, the sensitiveness of the amplifier could be increased to 100 microamps per millivolt with adequate screening.

The circuit was quite free from drifts and attained equilibrium in about half an hour after it was switched on. By adjusting the various resistances in the filament and the anode circuits of the valves, it was possible to make the drift exceedingly small, the maximum drift observed was 0.2 microamps per hour which was considerably less than 1 microamp per hour claimed by Mehta and Jatkar (loc. cit.). This drift did not affect the readings, as the equipment was used as a null instrument. The high stability of the instrument permitted the use of a sensitive galvanometer and the e.m.f. could be read accurately to about 1/10th of a millivolt, with the use of magnifying lens.

As already mentioned, the sensitivity of the instrument could be increased, but it was observed that by making the instrument more sensitive, various electrical impulses were picked up by the instrument and the stability was disturbed due to the oscillations of the galvano-

meter pointer. It was therefore necessary to construct the instrument in a manner such that a low gain per stage was obtained.

A series of pH measurements have been carried out using a glass electrode along with the above equipment. The glass electrode was made from Corning 015 glass in the shape of a long tapered cone about 15 cm long, with thin walls. A low resistance electrode of the type described by Johnson (*Chemistry and Industry*, 1939, **58**, 573) was tried, but it was found very difficult to cement all the capillaries together with paraffin and fill them with a reference solution. 0.1 N HCl was used as a reference solution along with silver—silver chloride electrode. The electrode system used was  $\text{Hg}|\text{HgCl}_2, \text{KCl} (\text{Satd}) || \text{solution pH}|\text{glass}|0.1 \text{ N HCl}, \text{AgCl}|\text{Ag}$ .

According to Mac-Innes and Dole (*J Amer Chem Soc*, 1930, **52**, 29), if the surface of the glass is reversible to the H-ion concentration, the electromotive force of the above combination is equal to the sum of the two cells,

- (1)  $\text{Hg}|\text{HgCl}_2, \text{KCl} (\text{Satd}) || \text{Solution pH}|\text{H}_2$  and
- (2)  $\text{H}_2|\text{HCl} (0.1 \text{ N}), \text{AgCl}-\text{Ag}$

The potential of the first cell at 25°C is  $E = 0.2452 + 0.05915 \text{ pH}$  and of the second  $-0.3524$  (Harned and co-workers, *J Amer Chem Soc*, 1930, **52**, 5079), therefore the electromotive force of the combination is  $E = -0.1066 + 0.05915 \text{ pH}$  at 25°C.

The cell used for the measurement of pH was of U-type described by Johnson (*loc cit*) and the buffer solutions used were Clerk and Lub's standard buffer mixtures. They were checked either against hydrogen or quinhydrone electrodes. A few measurements at 25°C are given in the following table.

Solution	Hydrogen Electrode pH	Quinhydrone Electrode pH	Glass Electrode	
			E M F	pH
I	2.67	2.67	0.0516	2.67
II	3.96	3.96	1276	3.96
III	5.94	5.94	.2449	5.94
IV	7.21	7.21	3199	7.21
V	8.78		4125	8.78
VI	9.41		4505	9.42

The results for the measurements of dissociation constants of organic acids will be published in future

#### SUMMARY

A two stage valve amplifier has been constructed for use with a glass electrode and consists of two electrometer triodes in push pull in the first stage and two Osram P<sub>2</sub> valves also in push pull in the second stage. The plate currents of valves was adjusted to give minimum drift in the galvanometer, which was 0.2 micro-amps hour. The sensitivity of the instrument was 0.8 microamps per millivolt and no screening was found necessary. With adequate screening and high anode voltages, the sensitivity could be increased to 100 microamps per millivolt. This was, however, not found necessary for present investigations. With Tinsley's Vernier type potentiometer and a sensitive unipivot galvanometer, the potentials could be read to 0.1 of a millivolt.

The equipment has been used for the measurement of pH and dissociation constants of acids.

*Department of Pure and Applied Chemistry,  
Indian Institute of Science,  
Bangalore*

23-9-1940