

# Analysis of an active noise control system with several loudspeakers spread along the axis of the duct

M. L. MUNJAL

Department of Mechanical Engineering, Indian Institute of Science, Bangalore 560 012, India.

Received on May 6, 1994; Revised on September 28, 1995.

## Abstract

In an active noise control system in a duct, often the primary source is so powerful that a single loudspeaker would not suffice for the auxiliary source; use of two, three or four speakers, located around the periphery of the duct, is common for large industrial blowers. However, for ducts of smaller diameter, the speakers have to be arranged along the axis, in which case they may interfere with each other instead of simply adding up. The present paper investigates this interaction analytically. A comprehensive one-dimensional standing-wave analysis is presented and an elegant closed-form expression has been derived for the overall performance (in terms of an 'advantage factor') for an auxiliary source comprising  $n$  identical speakers equi-spaced along the axis of the duct. This expression has been evaluated for two- and three-speaker sources and a design condition for the inter-speaker spacing has been obtained for an anechoic primary source that would ensure that all speakers of the auxiliary source work more or less in unison with each other.

**Keywords:** Noise control, active noise control, duct acoustics, technical acoustics.

## 1. Introduction

In an active noise control system, when the auxiliary source is tuned to the primary source, that is, when acoustic pressure at the error microphone tends to zero, it has been shown through a comprehensive plane wave analysis that at the junction of the auxiliary source and the duct, impedance is zero<sup>1</sup>. In other words, a tuned auxiliary source acts so as to produce an active short circuit in the duct. Acting against this zero impedance, the primary source governs the pressure field upstream of this junction, independent of the auxiliary source, as it were. Tuning is achieved by means of an adaptive controller, with the error microphone signal being used for the adaptation process, which produces the required transfer function<sup>2</sup>,  $H$  (Fig. 1). At this actively produced zero-impedance junction, the volume velocity produced by the primary source is equal and opposite to that produced by the tuned auxiliary source. For a very strong primary source, the maximum volume velocity produced by an ordinary loudspeaker would not be sufficient. Then two, three or four identical speakers are located around the duct. Often, for reasons of logistics, these speakers have to be located in a line along the axis rather than around the periphery of the duct. This would introduce phase differences so that zero impedance generated at the last loudspeaker, located towards the radiation end, would not be realised at the other loudspeakers upstream. This is the problem investigated in this paper.

Making use of Doak's modal model leading to an analytical expression for the three-dimensional pressure field generated by a rectangular constant velocity source in one of

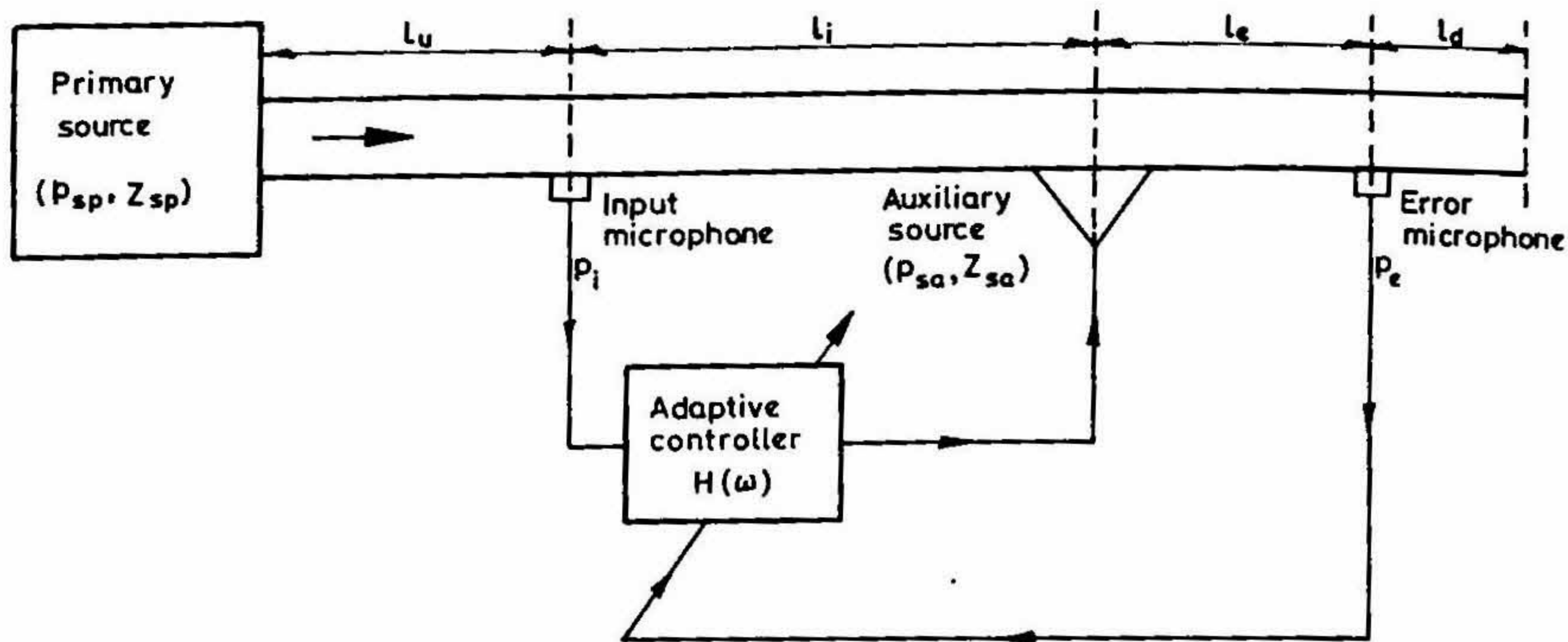

(a)

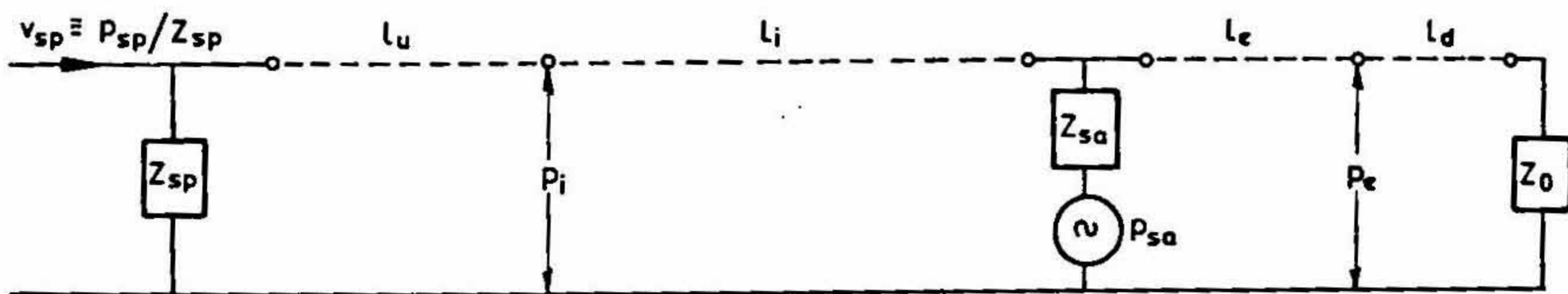

(b)

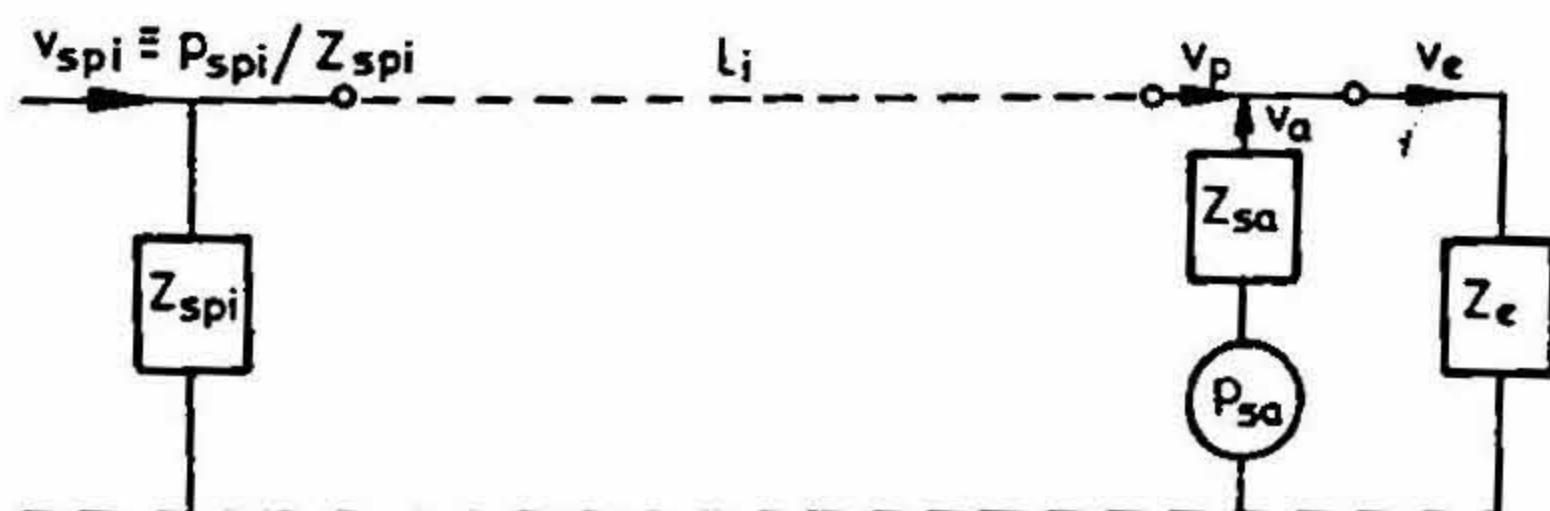

(c)

FIG. 1. a. Schematic of an active noise control system in a duct with single-speaker auxiliary source, b. its electrical analogous circuit using direct electroacoustic analogies; c. the interactive portion of the electrical analogous circuit.

the walls of an infinite rectangular duct<sup>3</sup>, Berengier and Roure have analysed the multi-loudspeaker problem<sup>4</sup>. However, their investigation implies the assumptions of (a) infinite (or anechoic) duct on either side of the auxiliary source as well as primary source, and (b) constant velocity (or infinite internal impedance) sources.

In the present paper, a comprehensive one-dimensional standing-wave analysis is presented, leading to an elegant closed-form expression for the overall performance for an auxiliary source comprising  $n$  identical speakers equispaced along the axis of the duct. Following Small<sup>5</sup>, electroacoustic analogies have been used. All analysis is in the frequency domain; the time dependence  $\exp(j\omega t)$  is skipped.

Only plane waves have been considered; the near-field effects of the speakers have been ignored. It is also assumed that the waves generated by both the sources are in the linear range. The convective effect of mean flow has not been taken into account. However, as indicated in Munjal and Eriksson<sup>1</sup>, though it can be readily incorporated, it is of little consequence. To start with, a system with a two-speaker auxiliary source is analysed. The final results are then generalized to any number of speakers.

## 2. Brief analysis of a tuned active noise control system

Use of omnidirectional microphones and speakers in an active noise control system in a duct calls for a standing wave analysis of the system with the auxiliary source (with source characteristics  $p_{sa}$  and  $z_{sa}$ ) as well as the primary source (with characteristics  $p_{sp}$  and  $z_{sp}$ ) in position, as shown in Fig. 1, where the primary source has been shown in its velocity representation. The acoustic source characteristics  $p_s$  and  $z_s$  correspond to the open-circuit voltage and internal impedance for an electrical source. Direct electro-acoustic analogies have been used wherein voltage and current correspond to acoustic pressure and volume velocity, respectively<sup>5,6</sup>. The main interactive portion of the system is shown in Fig. 1c, where  $p_{spi}$  and  $z_{spi}$  are the primary source characteristics transferred downstream to the input microphone location<sup>7</sup>.

The additional subscript  $i$  indicates the input microphone location, and  $z_e$  is the equivalent acoustic impedance of the duct downstream of the auxiliary source junction. Detailed nomenclature is provided in Appendix I.

An earlier investigation indicated that for a perfectly tuned system, the primary and the secondary sources present to each other zero impedance (acoustical short circuit) at the junction of the auxiliary source<sup>1</sup>;  $z_o$  is short-circuited. The use of transfer matrix relationships yields<sup>6</sup> (Fig. 2)

$$v_p = \frac{v_{spi}}{\cos kl_i + j \frac{Y}{Z_{sp}} \sin kl_i} \quad (1)$$

and

$$v_a = v_{sa} = p_{sa}/Z_{sa} \quad (2)$$

where  $Z_{sa}$  is the acoustic impedance of the auxiliary speaker, when inactive, as seen from the main duct side.

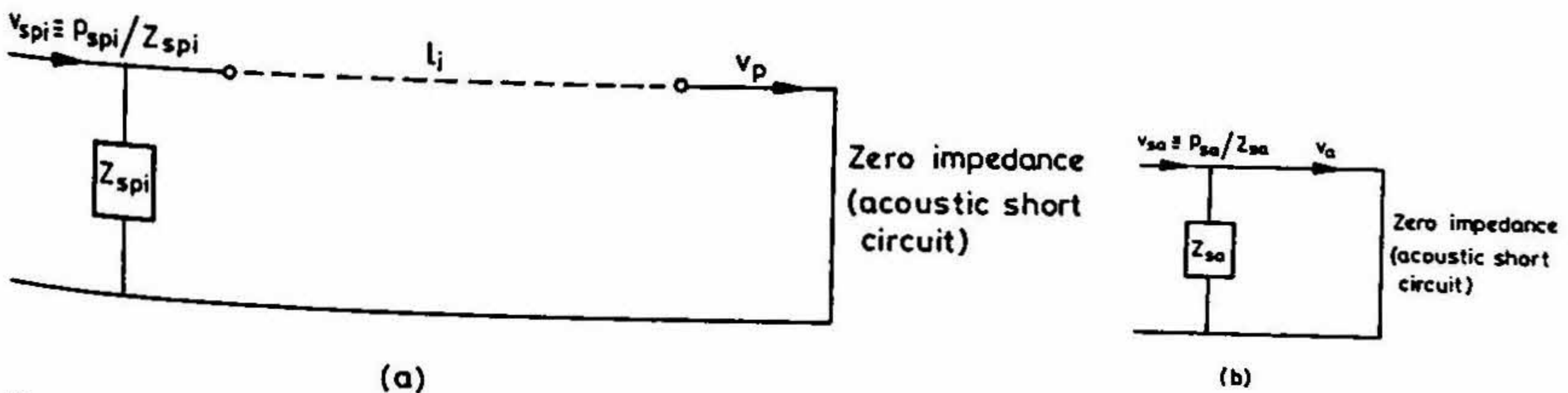

FIG. 2. Electrical analogous circuits for the tuned system. Contribution of a. primary source, and b. auxiliary source.

For  $v_e$  (and hence  $p_e$ ) in Fig. 1c to be zero, we must ensure that

$$v_a = -v_p. \quad (3)$$

Substituting from eqns (1) and (2), yields

$$v_{sa} = \frac{v_{spi}}{\cos kl_i + j \frac{Y}{Z_{spi}} \sin kl_i}. \quad (4)$$

Thus,  $p_{sa}$ , the acoustical equivalent of the open-circuit voltage of the power amplifier, is given by

$$p_{sa} = -\frac{Z_{sa}}{Z_{spi}} \frac{p_{spi}}{\cos kl_i + j \frac{Y}{Z_{spi}} \sin kl_i}. \quad (5)$$

Equation (3) indicates that the auxiliary source, often a loudspeaker, needs to be designed for the required volume velocity and not power, because the steady-state acoustical power output of the auxiliary source as well as the primary source of an ideally tuned system would be zero. The two sources then act together as an acoustical dipole in as much as they cancel each other's velocity output at the junction rather than power output which is zero. In other words, the two sources unload each other in that the resistive part of the acoustical load impedance faced by both of them is zero. This is true for industrial fans and engine exhaust systems where the primary source terminates the duct (Fig. 1a). This may not hold if the left end is open (the primary source being located in a wall of the duct, like the auxiliary source loudspeaker).

Throughout this paper, it is assumed that the primary source terminates the duct on the left, and the auxiliary source loudspeaker is wall mounted (Fig. 1a).

The velocity requirement given by eqn (4) is often so large that a single loudspeaker would not do; several speakers must be used to provide the volume velocity required for cancellation. For the ducts of large industrial blowers, one can locate two, three or four identical speakers around the periphery of the duct at the same cross-section. For smaller ducts, like the exhaust pipe of an automotive engine, these speakers must be arranged in line along the axis of the duct (Fig. 3). But this would in general cause mutual interference because they would see different portions (phases) of the standing wave in the duct. This problem is investigated analytically in the rest of this paper.

### 3. Analysis of a two-speaker system

Figure 3 shows an active noise control system with an auxiliary source consisting of two identical speakers of internal impedance  $Z_{sa}$  separated by an axial distance of  $l_a$ . Voice coils of the speakers are assumed to be subjected to the same voltage, the acoustical equivalent of which is  $p_{sa}$ . The problem consists in estimation of the volume velocity passing through  $Z_e$  due to the primary source and each of the two auxiliary loudspeakers. As the system is assumed to be linear, one may calculate the individual contributions of the three sources and then add the same up algebraically. The electrical analogous

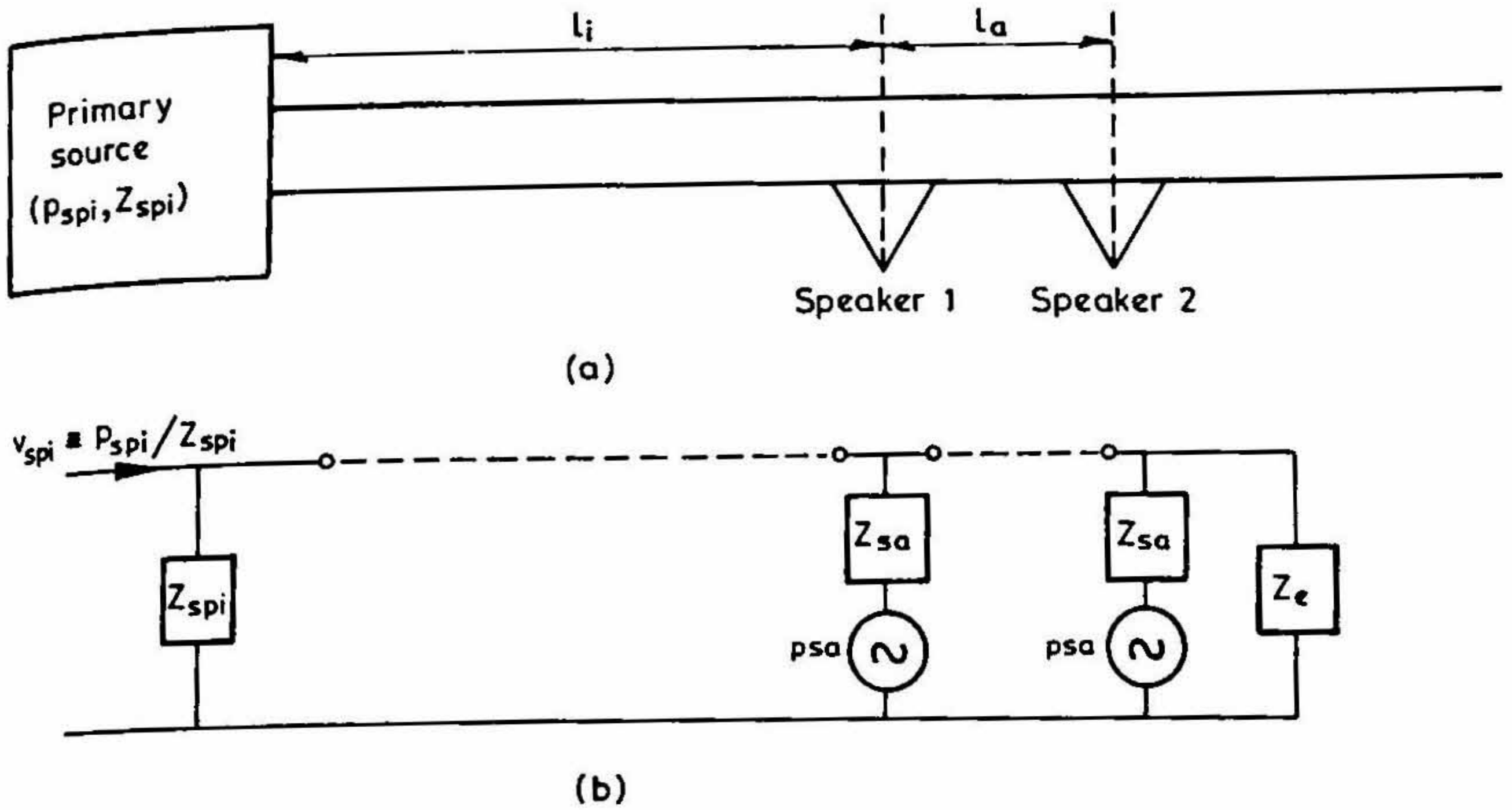

FIG. 3.a. Schematic of a system with a two-speaker auxiliary source; b. its electrical analogous circuit.

circuits for the three cases are shown in Figs 4a, 5a and 6a, respectively. Thus, applying the principle of superposition to the condition of multiple simultaneously operating sources,

$$v_e = v_{ep} + v_{ea1} + v_{ea2}. \tag{6}$$

Referring to Fig. 4a,  $v_{ep}$ , the contribution of the primary source alone to the volume velocity through the load impedance  $z_e$  may be written as

$$v_{ep} = \frac{v_{spi}}{v_{spi}/v_{ep}} = \frac{v_{spi}}{VR_0}, \quad VR_0 \equiv v_{spi}/v_{ep} \tag{7}$$

where the velocity ratio VR is defined for a passive subsystem (see Fig. 4b) as<sup>8</sup>

$$VR \equiv v_u / v_d \Big|_{p_d=0}. \tag{8}$$

The hypothetical condition of  $p_d = 0$  may be obtained by relocating  $z_e$  as shown in Fig. 4c.  $VR_0$  in eqn (7) for the system of Fig. 4c may be expressed directly in terms of the impedances and phase arguments of the constituent elements by means of Munjal *et al.*'s algebraic algorithm<sup>9</sup> without having to solve simultaneously a number of algebraic equations or multiplying successively a number of transfer matrices<sup>6</sup>. Thus,

$$VR_0 = C_i C_a + \frac{Z_e}{Z_{sa}} C_i C_a + j \frac{Z_e}{Y} C_i S_a + \frac{Z_e}{Z_{sa}} C_i C_a + j \frac{Z_e}{Y} S_i C_a + \frac{Z_e}{Z_{spi}} C_i C_a + j \frac{Y}{Z_{sa}} C_i S_a - S_i S_a + j \frac{Y}{Z_{spi}} C_i S_a + j \frac{Y}{Z_{spi}} S_i C_a + j \frac{Z_e Y}{Z_{sa}^2} C_i S_a - \frac{Z_e}{Z_{sa}} S_i S_a + j \frac{Z_e Y}{Z_{sa} Z_{spi}} C_i S_a$$

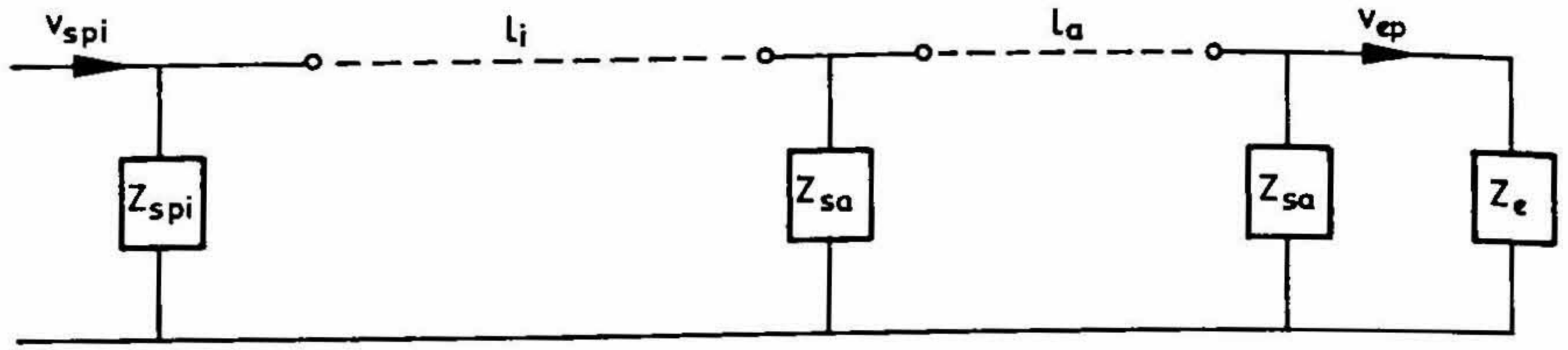

(a)

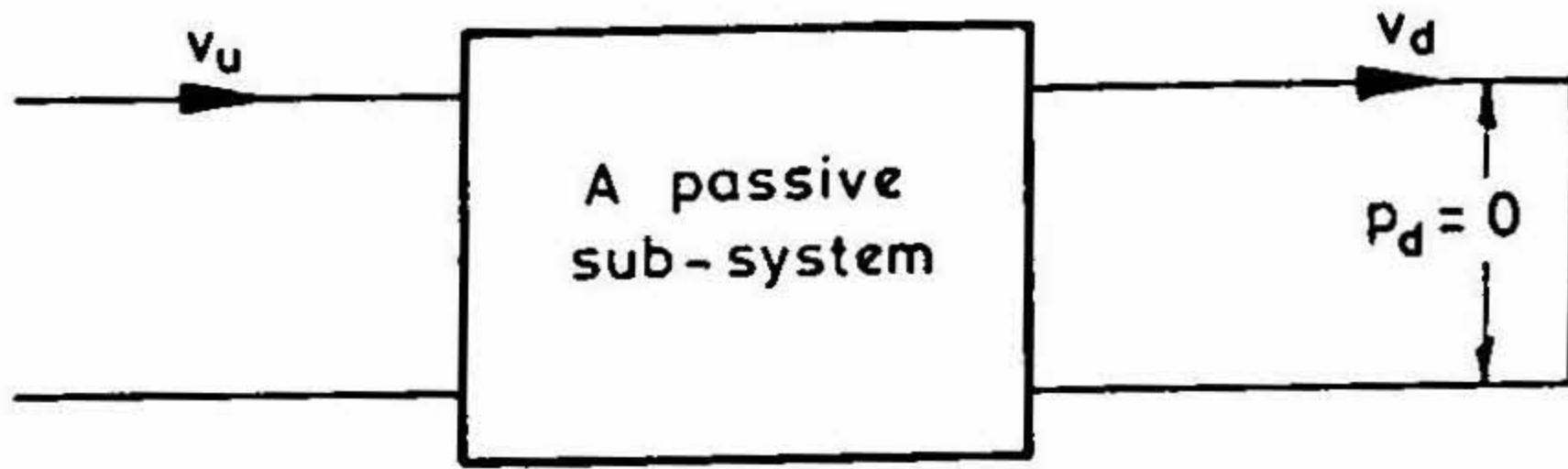

(b)

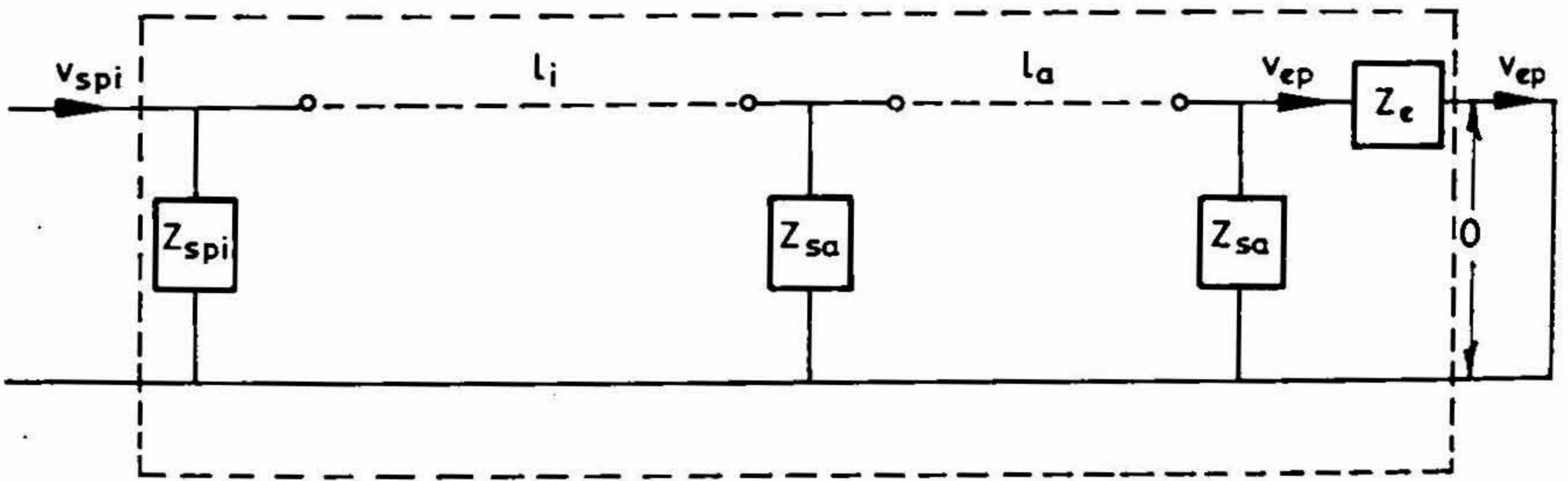

(c)

FIG. 4.a. The system with only the primary source active; b. block diagram for definition of the velocity ratio:  $VR_n \equiv v_u/v_d|_{p_d=0}$ ; c. the system of Fig. 4a with the load impedance  $Z_e$  relocated to correspond with the block diagram of Fig. 4b for evaluation of the velocity ratio:  $VR_0 = v_{spi}/v_{ep}$ .

$$+j \frac{Z_e Y}{Z_{sa} Z_{spi}} S_i C_a - \frac{Y^2}{Z_{sa} Z_{spi}} S_i S_a - \frac{Z_e Y^2}{Z_{sa}^2 Z_{spi}} S_i S_a \tag{9}$$

where

$$\begin{aligned} C_i &\equiv \cos kl_i, & S_i &\equiv \sin kl_i \\ C_a &\equiv \cos kl_a, & S_a &\equiv \sin kl_a. \end{aligned} \tag{10}$$

Incidentally, a reader not accustomed to the algebraic algorithm<sup>9</sup> may derive eqn (9) by means of the transfer matrix method<sup>6</sup>, which was used in the first place to develop the algorithm.

Referring to Fig. 5a,  $v_{a11}$ , the volume velocity produced by the auxiliary source speaker 1 is given by

$$v_{am} = v_{L1} + v_{R1} = p_{sa}/\zeta_1 \tag{11}$$

where  $\zeta_1$  is the total impedance faced by speaker 1.

$$\zeta_1 = Z_{sa} + \frac{\zeta_{L1} \zeta_{R1}}{\zeta_{L1} + \zeta_{R1}}, \tag{12}$$

where  $\zeta_{L1}$  and  $\zeta_{R1}$  are the equivalent acoustic impedances on the left- and right-hand sides, respectively, of speaker 1. These may readily be calculated by means of the transfer matrix method<sup>6</sup>. Thus,

$$\zeta_{L1} = \frac{Z_{spi} C_i + j Y S_i}{j \frac{Z_{spi}}{Y} S_i + C_i} \tag{13}$$

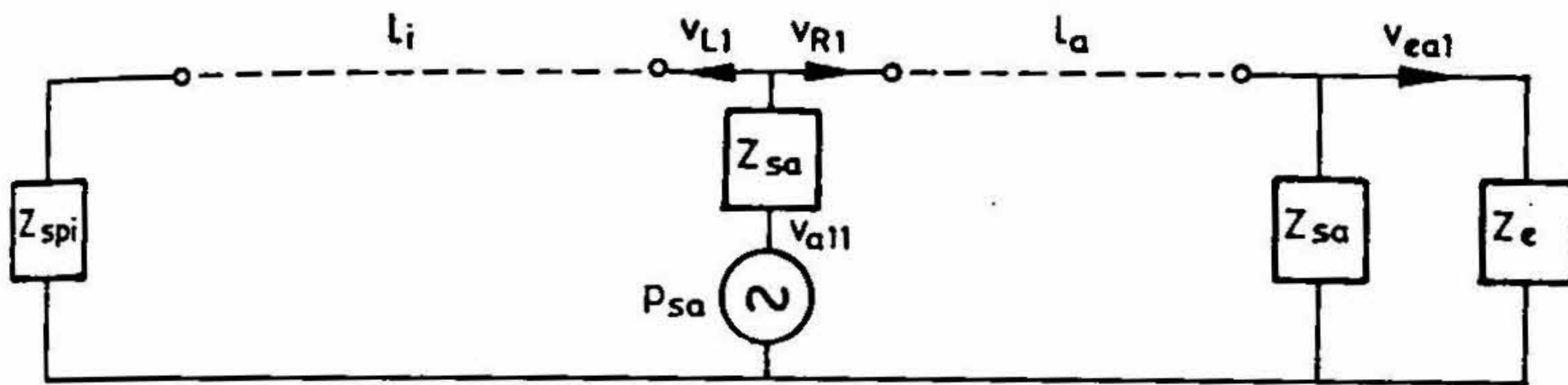

(a)

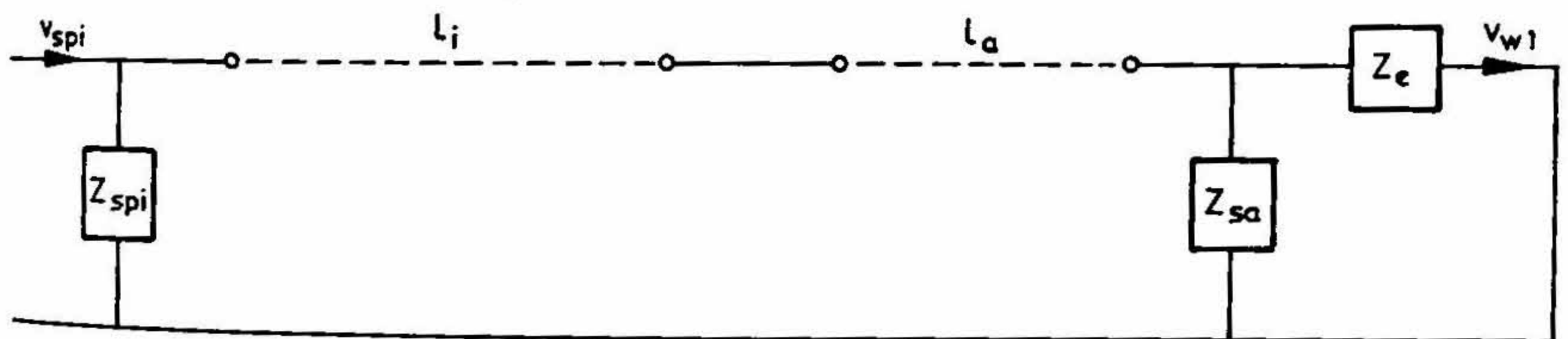

(b)

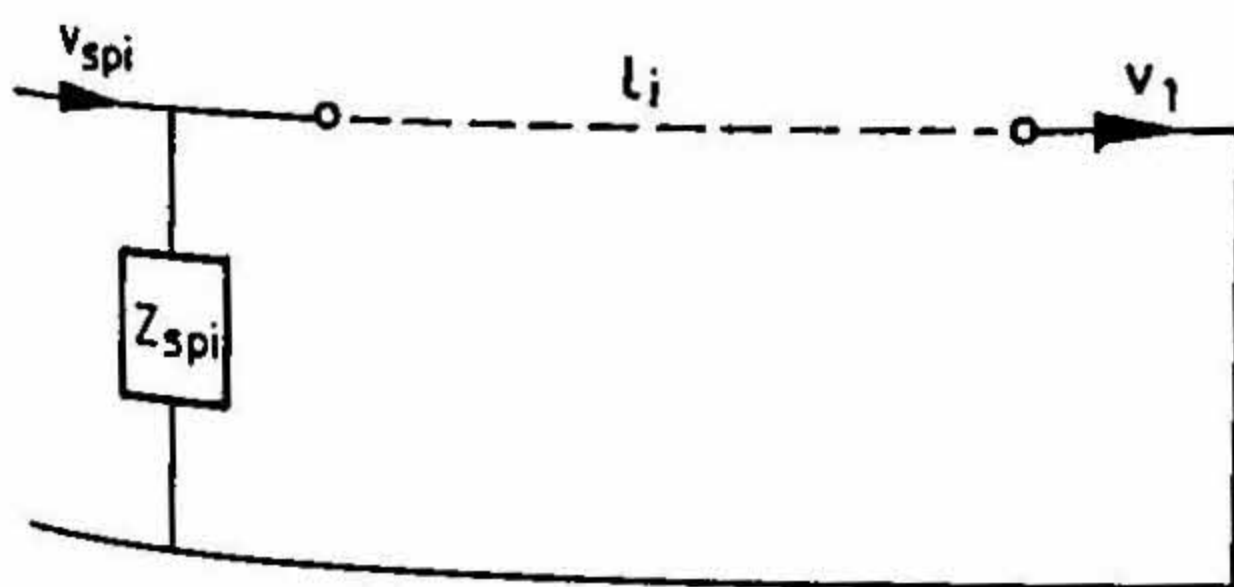

(c)

FIG. 5.a. The system with only the first speaker of the auxiliary source active; b. the system of Fig. 5a without speaker 1 for definition of the velocity ratio  $VR_{w1} \equiv v_{spi}/v_{w1}$ ; c. the system of Fig. 5a with an acoustical short circuit at the location of speaker 1 for definition of the velocity ratio  $VR_1 \equiv v_{spi}/v_1$ .

$$\zeta_{R1} = \frac{\frac{Z_e Z_{sa}}{Z_e + Z_{sa}} C_a + j Y S_a}{j \frac{Z_e Z_{sa}}{Z_e + Z_{sa}} \frac{S_a}{Y} + C_a} \quad (14)$$

On substitution of these expressions in eqn (12), and after some simple rearrangement, one finds that  $\zeta_1$ , the total impedance faced by speaker 1, turns out to be

$$\zeta_1 = Z_{sa} \frac{VR_0}{VR_{w1}} \quad (15)$$

Here  $VR_0$  is the velocity ratio defined by Fig. 4c and given by eqn (9) and  $VR_{w1}$  is the velocity ratio defined in Fig. 5b, which is Fig. 5a without the speaker 1 branch. Again, making use of the algebraic algorithm<sup>9</sup>,

$$\begin{aligned} VR_{w1} = & C_a C_i + \frac{Z_e}{Z_{sa}} C_a C_i + j \frac{Z_e}{Y} S_a C_i + j \frac{Z_e}{Y} C_a S_i + \frac{Z_e}{Z_{spi}} C_a C_i - S_a S_i + j \frac{Y}{Z_{spi}} S_a C_i \\ & + j \frac{Y}{Z_{spi}} C_a S_i - \frac{Z_e}{Z_{sa}} S_a S_i + j \frac{Z_e Y}{Z_{sa} Z_{spi}} S_a C_i + j \frac{Z_e Y}{Z_{sa} Z_{spi}} C_a S_i - \frac{Z_e}{Z_{spi}} S_a S_i \end{aligned} \quad (16)$$

where  $S_a$ ,  $S_i$ ,  $C_a$  and  $C_i$  are as defined in eqn (10).

Now  $V_{R1}$  and  $V_{ea1}$  in Fig. 5a may be calculated as under:

$$V_{R1} = V_{a11} \zeta_{L1} / (\zeta_{L1} + \zeta_{R1}), \quad V_{ea1} = V_{R1} / VR_{R1} \quad (17)$$

where the velocity ratio

$$VR_{R1} \equiv V_{R1} / V_{ea1} = C_a + \frac{Z_e}{Z_{sa}} C_a + j \frac{Z_e}{Y} S_a \quad (18)$$

Now,  $V_{a1}$  may be evaluated by substituting eqn (15) in eqn (11). The resulting equation along with eqns (13) and (14), when substituted in eqn (17), yields an expression for  $VR_1$ . Substituting this and eqn (18) in eqn (21) yields, after some simple algebraic manipulation,

$$v_{ea1} = v_{sa} \frac{VR_1}{VR_0}, \quad v_{sa} \equiv P_{sa} / Z_{sa} \quad (19)$$

and the velocity ratio  $VR_1$  is defined in Fig. 5c where an acoustical short circuit occurs at the location of speaker 1. Making use of the algebraic algorithm<sup>9</sup>,

$$VR_1 = C_i + j \frac{Y}{Z_{spi}} S_i \quad (20)$$

$v_{ea2}$ , the contribution to the volume velocity through  $Z_e$  (Fig. 6a), can be evaluated in a manner similar to  $v_{ea1}$ . It has been found that  $\zeta_2$ , the total impedance faced by the auxiliary source speaker 2 in Fig. 6a, is given by

$$\zeta_2 = Z_{sa} \frac{VR_0}{VR_{w2}} \quad (21)$$



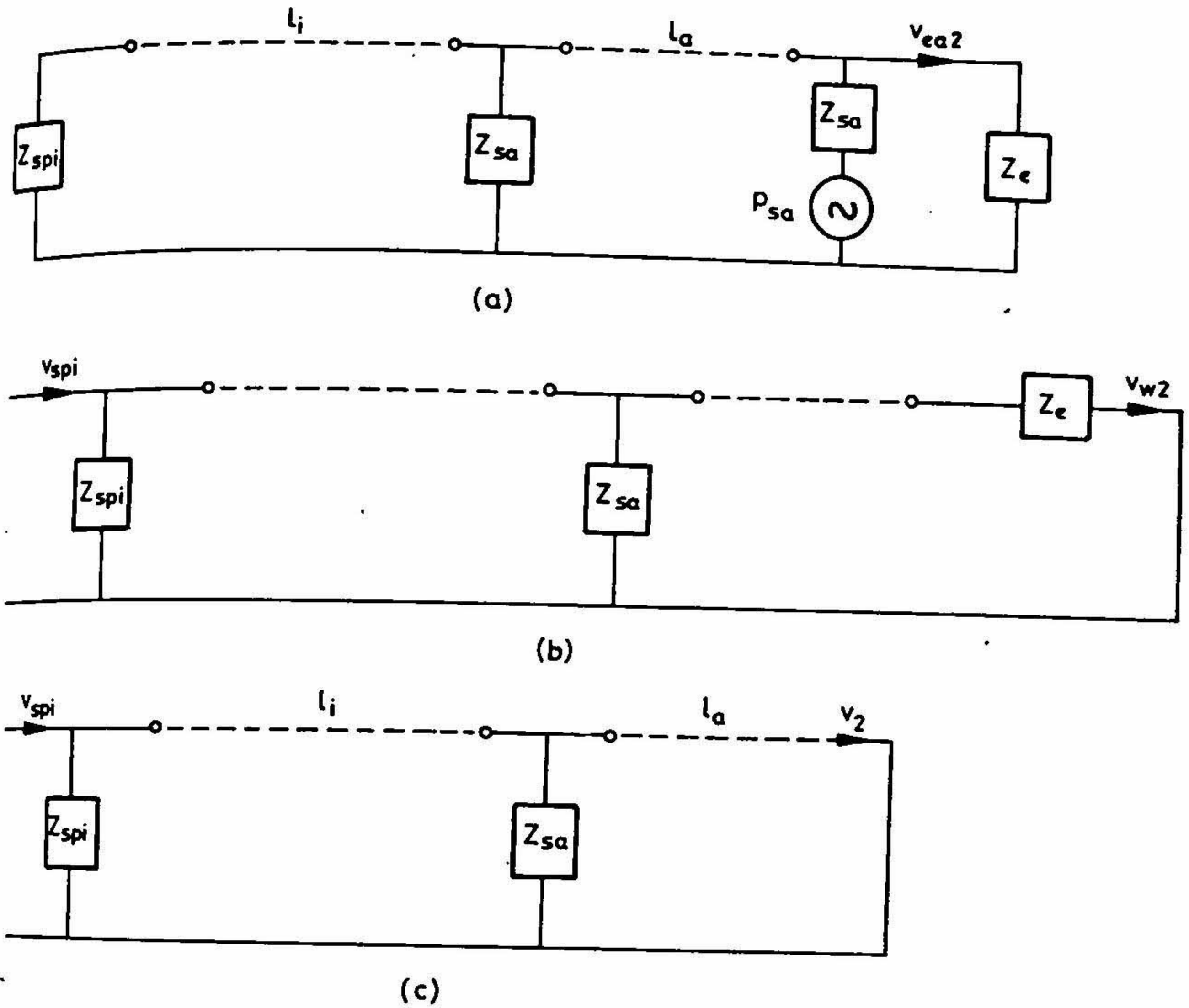

FIG. 6.a. The system with only the second speaker of the auxiliary source active; b. the system of Fig. 6a without speaker 2 for definition of velocity ratio  $VR_{w2} \equiv v_{spi}/v_{w2}$ ; c. the system of Fig. 6a with an acoustical short circuit at the location of speaker 2 for definition of the velocity ratio  $VR_2 \equiv v_{spi}/v_2$ .

where  $VR_{w2}$  is the velocity ratio defined in Fig. 6b [cf. eqn (15) and Fig. 5b] and that

$$v_{ea2} = v_{sa} \frac{VR_2}{VR_0}, \quad (22)$$

where  $VR_2$  is the velocity ratio defined in Fig 6c, which is indeed Fig. 6a with the speaker 2 branch short-circuited. Again, making use of the algebraic algorithm<sup>9</sup>,

$$VR_2 = C_a C_i + j \frac{Y}{Z_{sa}} S_a C_i - S_a S_i + j \frac{Y}{Z_{spi}} S_a C_i + j \frac{Y}{Z_{spi}} C_a S_i - \frac{Y^2}{Z_{sa} Z_{spi}} S_a S_i \quad (23)$$

[cf. eqn (19) and Fig. 5c].

For perfect tuning required for complete cancellation, total pressure across  $Z_e$  must be zero, which requires

$$p_e = V_e Z_e = (v_{ep} + v_{ea1} + v_{ea2}) Z_e = 0 \quad (24)$$

or

$$v_{ep} + v_{ea1} + v_{ea2} = 0. \quad (25)$$

Substituting expressions (7), (19) and (22) for  $v_{ep}$ ,  $v_{ea1}$  and  $v_{ea2}$ , respectively, into eqn (25) yields

$$v_{spi} + v_{sa} VR_1 + v_{sa} VR_2 = 0. \quad (26)$$

Thus, for a system with a two-speaker auxiliary source, the required value of  $v_{sa}$  is given by

$$v_{sa} = -\frac{v_{spi}}{VR_1 + VR_2}. \quad (27)$$

#### 4. Generalization to a multi-speaker system

It may be recalled here that Fig. 2a for a single-speaker auxiliary source is identically similar to Fig. 5c, and eqns (4), (19) and (20) yield

$$v_{sa,1} = -\frac{v_{sp}}{VR_1}. \quad (28)$$

Formal similarity of eqns (27) and (28) leads to the following generalization for an  $n$ -speaker system.

$$v_{sa,n} = -\frac{v_{spi}}{VR_1 + VR_2 + \dots + VR_n}. \quad (29)$$

An insight into the physics of the active noise control system can be had by rewriting eqn (29) as

$$\frac{1}{v_{sa,n}} = -\left( \frac{1}{v_1} + \frac{1}{v_2} + \dots + \frac{1}{v_i} + \dots + \frac{1}{v_n} \right), \quad (30)$$

where  $v_i$  is the volume velocity that would be produced by the primary source at the  $i$ th speaker junction if there was an acoustical short circuit (zero impedance) at that junction, while all other speakers constituting the auxiliary source are inactive with their internal impedance  $z_{sa}$  in position (see Figs 5c and 6c for illustration).

The advantage of using  $n$  identical, equi-spaced loudspeakers instead of a single speaker for the auxiliary source, can be measured in terms of an advantage factor  $AF$  that can be calculated from eqns (28) and (29):

$$AF \equiv \left| \frac{v_{sa,1}}{v_{sa,n}} \right| = \left| 1 + \frac{VR_2}{VR_1} + \frac{VR_3}{VR_1} + \dots + \frac{VR_n}{VR_1} \right|. \quad (31)$$

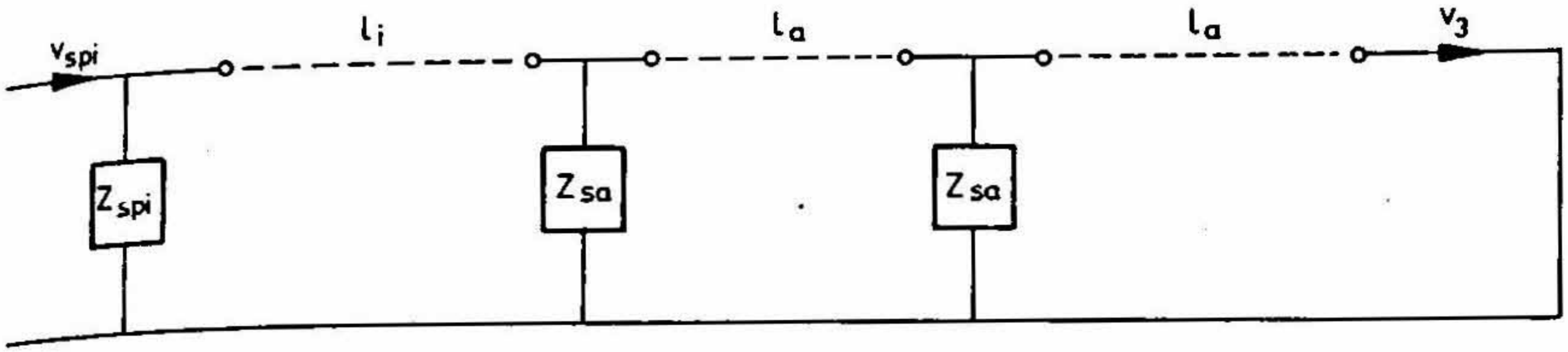

FIG. 7. The electrical analogous circuit for a three-speaker auxiliary source system with short circuit at the third speaker for definition of the velocity ratio  $VR_3 \equiv v_{spi}/v_3$ .

If the near-field effects were negligible, as has been assumed here, then ideally the advantage factor with  $n$  speakers should be equal to  $n$ , which would be achieved if all  $n$  speakers were located at the same cross-section (distributed around the periphery of the duct), or feeding in at the same cross-section, because then  $VR_2 = VR_3 = \dots = VR_n = VR_1$ .

For the special case of an anechoic primary source ( $Z_{spi} = Y$ ), it can be shown that  $VR_1$  is a common factor of  $VR_2, VR_3, \dots, VR_n$ . For example, eqns (20) and (23) yield

$$\lim_{Z_{spi} \rightarrow Y} \frac{VR_2}{VR_1} = C_a + j \frac{Y}{Z_{sa}} S_a + j S_a. \quad (32)$$

Similarly, writing out  $VR_3$  by means of the algebraic algorithm<sup>9</sup>, it is seen that  $VR_3$  (Fig. 7) too is divisible by  $VR_1$  and

$$\lim_{Z_{spi} \rightarrow Y} \frac{VR_3}{VR_1} = C_a^2 + j3 \frac{Y}{Z_{sa}} S_a C_a - S_a^2 + j2 S_a C_a - \frac{Y_a^2}{Z_{sa}^2} S_a^2 - \frac{Y}{Z_{sa}} S_a^2. \quad (33)$$

Thus,  $VR_2/VR_1, VR_3/VR_1, \dots, VR_n/VR_1$ , and thence the advantage factor  $AF$ , for anechoic primary source, turns out to be independent of  $l_i$ , the axial distance between the input microphone and the first speaker.

Incidentally, it may be checked from eqns (32) and (33) that if  $l_a$  and hence  $kl_a$  tended to zero, then  $AF$  would tend to  $n$ .

Logically, this should hold within reasonable tolerances when  $kl_a$  is small enough but not necessarily tending to zero. Permissible range of values for  $kl_a$  is obtained hereunder by evaluating the advantage factor for typical loudspeakers.

## 5. Results and discussion

The foregoing analysis suggests that the total impedance faced by the  $i$ th auxiliary source speaker is given by

$$\zeta_i = Z_{sa} \frac{VR_0}{VR_{wi}} \quad (34)$$

where  $VR_0$  is the velocity ratio of the total system as defined in Fig. 4c,  $VR_{wi}$ , the velocity ratio of the system without the  $i$ th speaker branch as illustrated in Figs 5b and 6b for

the first and second speakers, respectively, and  $Z_{sa}$  is the internal impedance of the speaker as manifested at the junction looking in from the main duct.

It is also now clear that contribution of the  $i$ th speaker to the volume velocity through the acoustic load  $Z_e$  at the last ( $n$ th) speaker junction is given by

$$v_{eai} = v_{sa} \frac{VR_i}{VR_0} \quad (35)$$

where  $VR_i$  is the velocity ratio of the system with an acoustical short circuit at the  $i$ th speaker, and  $v_{sa} = p_{sa}/Z_{sa}$  is the volume velocity of the speaker at the junction against zero impedance.

Figure 8 shows the configuration of a typical speaker attached to the main duct as an auxiliary source or as one of the speakers thereof. Alongside is shown its electrical analogous circuit.  $Z_{sa}$ , the impedance of the inactive speaker looking in from the main duct side may be calculated making use of Small's generalization of Beranek's theory<sup>5</sup> (Appendix II), which also gives geometrical and electroacoustical details of the system. A stretched membrane is provided to protect the speaker from the heat and corrosion due to gases in the main duct. It has been modelled in Appendix II as an inertance.

Assuming the primary source to be anechoic, advantage levels defined as

$$AL = 20 \log_{10} (AF) \quad (36)$$

were computed from eqns (31), (32), (33) and (36) for a two- and a three-speaker auxiliary source systems, with  $l_a$ , the inter-speaker distance as 0.18 m (Fig. 9).

It may be observed from Fig. 9 that up to a certain frequency the advantage level for the two-speaker system is about 6 dB (corresponding to  $AF = 2$ ) and that for the three-speaker system is about 10 dB (corresponding to  $AF = 3$ ). Beyond this frequency the advantage level falls owing to the mutual interference due to increased phase differences

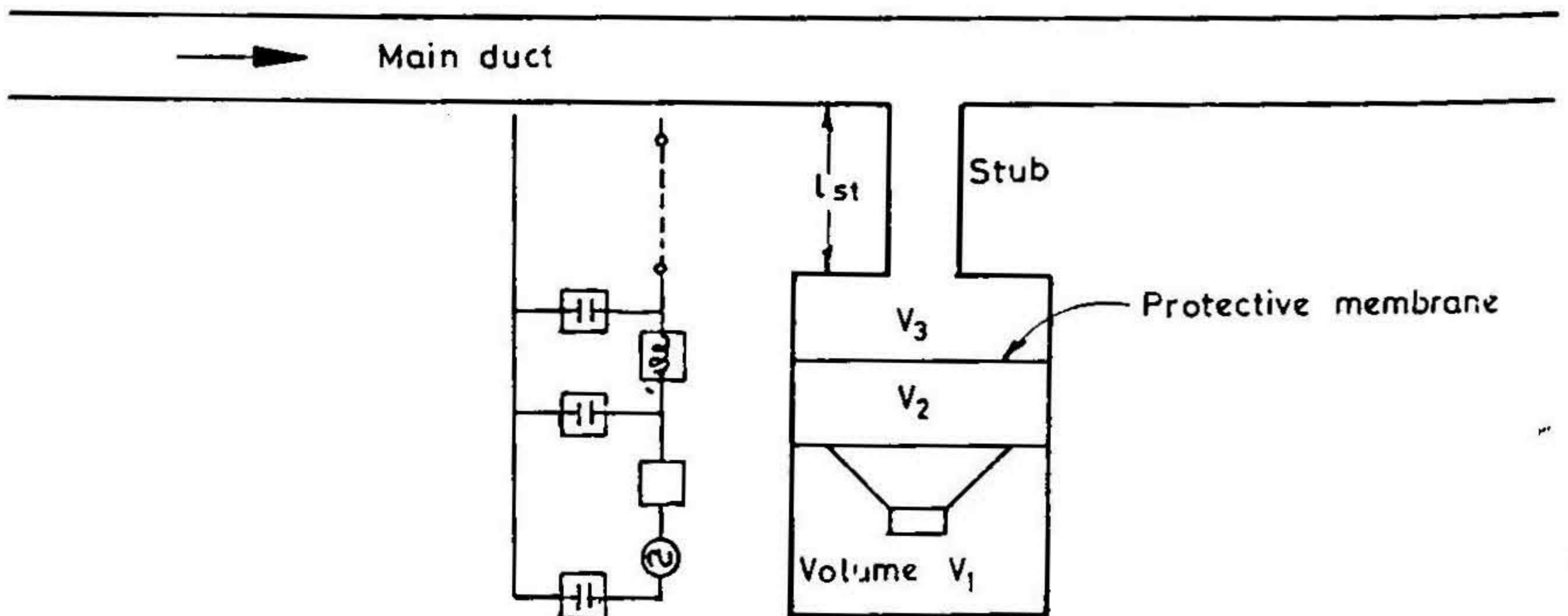

FIG. 8. Line sketch of a speaker attached to the main duct.  $Z_{sa}$  is the impedance of the inactive speaker as seen from the main duct side.

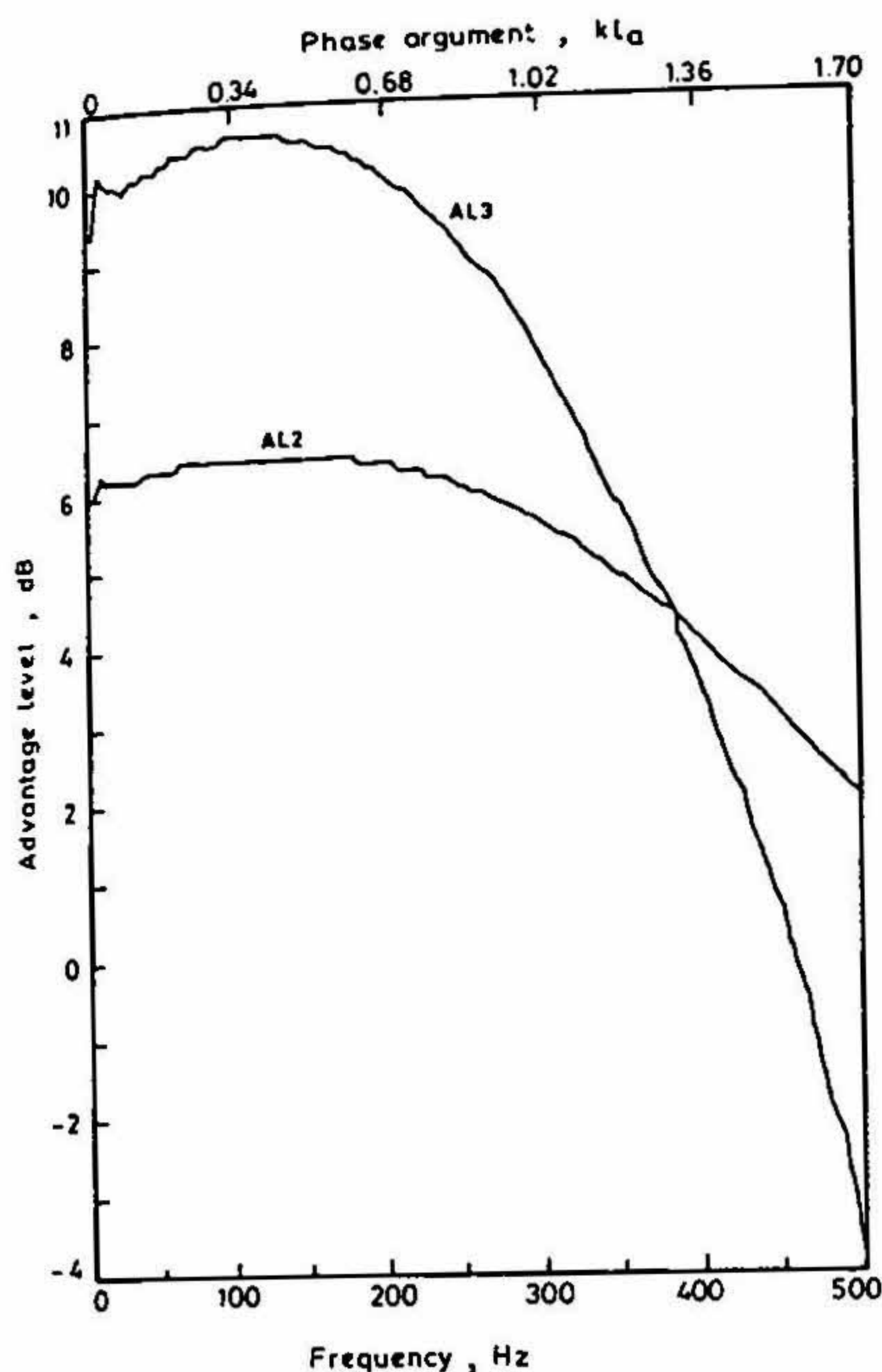

FIG. 9. Advantage levels for two- (AL2) and three-speaker systems (AL3).

represented by the argument  $kl_a$ , as would indeed be expected from eqns (32) and (33) when read with identities (10). It may also be observed from Fig. 9 that the fall in AL due to interference is sharper for the three-speaker system (about 12 dB/octave) than for the two-speaker auxiliary source system (about 3 dB/octave). This is also reasonable because the more the number of speakers constituting the auxiliary source the more susceptible the system will be to the inter-speaker interference.

A quantitative estimate can be obtained by noting that up to 2 dB of fall in AL occurs at  $f = 400$  Hz for the two-speaker system, and  $f = 290$  Hz for the three-speaker system. Values of the phase argument  $kl_a$  corresponding to 400 and 290 Hz are 1.31 and 0.95, respectively. This information should help the designer in the choice of  $l_a$  for a given upper limit of the frequency of interest.

## 6. Conclusions

The foregoing investigation leads to the following general conclusions:

- (a) The standing wave analysis of an active noise control system in a duct with the auxiliary source consisting of several speakers can be done conveniently by means of the

concept of velocity ratio<sup>8</sup> and the algebraic algorithm<sup>9</sup>. The electroacoustic analogies come in handy for the purpose.

(b) The  $v_{sa}$  requirement of each of the  $n$  speakers constituting auxiliary source is given by eqn (29) or (30), which incidentally gives an insight into the physics of the active noise control system as a velocity cancellation system.

(c) The maximum distance  $l_a$  between two consecutive speakers for the highest frequency of interest is given by  $kl_a = 1.31$  for a two-speaker auxiliary source, and  $kl_a = 0.95$  for a three-speaker auxiliary source. These values however suffer from a basic limitation of the plane wave analysis which neglects near-field or three-dimensional effects<sup>3, 4</sup>.

### Acknowledgements

The work reported here was done by the author at the Corporate Research Department of Nelson Industries, Inc., Wisconsin, during a short visit. The author acknowledges with thanks the discussions he had with Mike Zuroski and Mark Allie of their Acoustics Research Group.

### References

1. MUNJAL, M. L. AND ERIKSSON, L. J. An analytical one-dimensional, standing-wave model of a linear active noise control system in a duct, *J. Acoust. Soc. Am.*, 1988, **84**, 1086–1093.
2. ERIKSSON, L. J. Development of the filtered-U algorithm for active noise control, *J. Acoust. Soc. Am.*, 1991, **89**, 257–265.
3. DOAK, P. E. Excitation, transmission and radiation of sound from source distributions in hard-walled ducts of finite length (I): The effects of duct cross-section geometry and source distribution space-time pattern, *J. Sound Vib.*, 1973, **31**, 1–72.
4. BERENGIER, M. AND ROURE, A. Radiation impedance of one or several real sources mounted in a hard-walled rectangular waveguide, *J. Sound Vib.*, 1980, **71**, 389–398.
5. SMALL, R. H. Closed-box loudspeaker systems, *J. Audio Engng Soc.*, 1973, **21**, 11.
6. MUNJAL, M. L. *Acoustics of ducts and mufflers*, 1987, Wiley-Interscience.
7. MUNJAL, M. L. AND DOIGE, A. G. On uniqueness, transfer and combination of acoustic sources in one-dimensional systems, *J. Sound Vib.*, 1988, **121**, 25–35.
8. MUNJAL, M. L., SREENATH, A. V. AND NARASIMHAN, M. V. Velocity ratio in the analysis of one-dimensional linear dynamical systems, *J. Sound Vib.*, 1973, **26**, 173–191.
9. MUNJAL, M. L., SREENATH, A. V. AND NARASIMHAN, M. V. An algebraic algorithm for the design and analysis of one-dimensional linear dynamical systems, *J. Sound Vib.*, 1973, **26**, 193–208.

**Appendix I****Nomenclature**

- $c$  : sound speed  
 $C$  : cosine function [defined in eqn (10)]  
 $H$  : transfer function  $p_{sa}/p_i$   
 $k$  : wave number,  $\omega/c$   
 $l$  : length  
 $p$  : acoustic pressure  
 $S$  : area of cross-section; sine function [defined in eqn (10)]  
 $v$  : acoustic volume velocity  
 $VR$  : velocity ratio [defined in eqn (8)]  
 $Y$  : characteristic impedance,  $\rho c/S$   
 $Z$  : acoustic impedance of an element or at a point  
 $\rho$  : density  
 $\zeta$  : equivalent acoustic impedance of a subsystem at a point upstream

**Subscripts**

- $a$  : auxiliary (source); contribution of the auxiliary source  
 $d$  : downstream  
 $e$  : at or next to the error microphone location  
 $i$  : at or next to the input microphone location  
 $L$  : left-hand side  
 $o$  : radiation point; original (unmodified) system  
 $p$  : primary (source); contribution of the primary source  
 $R$  : right-hand side  
 $s$  : source  
 $u$  : upstream  
 $wi$  : without the  $i$ th speaker branch  
 $1$  : relevant to the auxiliary source speaker 1  
 $2$  : relevant to the auxiliary source speaker 2

**Appendix II****Details of the system of Fig. 9**

Primary source is assumed to be anechoic so that  $Z_{spi} = Z_{sp} = Y = \rho c/S$

$\rho = 1.2 \text{ kg/m}^3$ ,  $c = 333.3 \text{ m/s}$ , pipe diameter,  $d = 0.054 \text{ m}$ ,  $S = \frac{\pi}{4} d^2$

Distance between the input microphone and the nearest speaker,  $l_i = 2.0 \text{ m}$

Axial distance between centreline of two consecutive speakers,  $l_a = 0.18 \text{ m}$

**Loudspeaker details**

Mechanical mass of the diaphragm,  $M_{md} = 0.013 \text{ kg}$

Mechanical compliance of the suspension,  $C_{ms} = 0.0007 \text{ m/N}$

Mechanical resistance of the suspension,  $R_{ms} = 0.52$  mech.ohm

Area of cross-section of the diaphragm,  $S_d = 0.0142$  m<sup>2</sup>

Product of the magnetic flux density and length of the wound wire in the moving coil,  $Bl = 7.3$  N/amp.

Electrical resistance of the moving coil,  $R_e = 3$

Electrical inductance of the moving coil,  $L_e = 1.23$  mH

Mass of the protective membrane,  $M_m = 0.022$  kg

Cross-sectional area of the membrane,  $S_m = 0.032$  m<sup>2</sup>

Port or stub cross-sectional area,  $S_{st} = 0.00083$  m<sup>2</sup>

Port or stub length,  $l_{st} = 0.2$  m

Volume  $V_1 = 0.00268$  m<sup>3</sup>

Volume  $V_2 = 0.00092$  m<sup>3</sup>

Volume  $V_3 = 0.00225$  m<sup>3</sup>

### Evaluation of $Z_{sa}$

$Z_{sa}$ , the acoustic impedance of the inactive speaker as seen from the main duct side (see Fig. 8), may be evaluated as follows<sup>5,6</sup>

$$Z_{sa} = \frac{Z''_{sa} \cos(kl_{st}) + jY_{st} \sin(kl_{st})}{j \frac{Z''_{sa}}{Y_{st}} \sin(kl_{st}) + \cos(kl_{st})}$$

where

$$Y_{st} = \rho c / S_{st}$$

$$Z''_{sa} = \frac{(Z'_{sa} + Z_m) Z_{b3}}{(Z'_{sa} + Z_m) + Z_{b3}}$$

$$Z_m = j\omega M_m / S_m^2$$

$$Z'_{sa} = \frac{\left\{ Z_{sa}(0) + \frac{1}{j\omega C_{AB1}} \right\} \frac{1}{j\omega C_{AB2}}}{\left\{ Z_{sa}(0) + \frac{1}{j\omega C_{AB1}} \right\} + \frac{1}{j\omega C_{AB2}}}$$

$$C_{AB1} = \frac{V_1}{\rho c^2}$$

$$C_{AB2} = \frac{V_2}{\rho c^2}$$

$$Z_{sa}(0) = \frac{(Bl / S_d)^2}{j\omega L_e + R_e} + j\omega M_{AS} + R_{AS} + \frac{1}{j\omega C_{AS}}$$

$$M_{AS} = M_{md} / S_d^2$$

$$R_{AS} = R_{ms} / S_d^2$$

$$C_{AS} = C_{ms} / S_d^2$$