



Acquisition time improvement of PLL* using some aiding functions

Y. VENKATARAMAYYA* AND B. S. SONDE

Department of Electrical Communication Engineering, Indian Institute of Science, Bangalore 560 012, India.

Abstract

Phase-lock loops (PLL^s) are now receiving wide attention from communication system designers. Though the primary function of a PLL is to track a received signal, it has to acquire the signal first. A low value of acquisition time (t_{ac}) is of immense practical importance for PLL applications, particularly in space communication, electronic warfare, etc. Therefore, analytical studies have been carried out for the minimization of t_{ac} using some aiding functions. To experimentally verify the analytical evaluation, a second order aided PLL has been realized along with the chosen aiding functions using the state-of-the-art components and this has yielded satisfactory results. The analytical and experimental studies are presented in this paper.

Key words : Phase-lock loop, PLL, acquisition time, aided acquisition, acquisition time measurement.

1. Introduction

The PLL is essentially an electronic servo-loop which is finding increasing application in signal tracking. Before the received signal is tracked, a PLL has to acquire the signal. In the signal acquisition mode, the performance of a PLL is governed by the product of signal acquisition range ω_s and t_{ac} . A large ω_s and a small t_{ac} are usually desirable for a PLL. So, it is important to reduce t_{ac} of a PLL by some means or the other. The analysis of locking behaviour in the frequency search mode is difficult as the PLL is described by a nonlinear, non-autonomous differential equation which is not amenable for easy solution.

The quasilinearization technique for a PLL, whether unaided or aided, gives a direct physical insight into its acquisition behaviour and yields a closed form solution for t_{ac} . The measurement of t_{ac} is important equally for an aided as well as an unaided

* Now with the E & C Department, College of Engineering, Gulbarga.

PLL. The t_{ac} can be measured by two methods, viz., (i) from the study of L.P.F. output transient, and (ii) by employing a lock detecting and indicating circuit. If measurements are carried out by both these methods, it is very useful to cross-check the experimental results as well as to check the validity of the analytical results. Therefore, both these methods are employed in the experimental work reported in this paper.

2. Acquisition in PLL : A state of the art review

The acquisition time evaluation of a PLL can be made using the phase-plane technique¹. Using the phase-plane portrait and some linearization techniques²⁻⁵, the nonlinear differential equation of a PLL is studied. Though the phase-plane portrait completely describes the performance of certain PLL¹, it is not accurate enough to describe a phase-lock receiver. The linearization techniques do not give very accurate results for large/small detuning. But the evaluation made using quasi-stationary approach^{3,4} is a powerful technique and it leads to a closed form solution of t_{ac} with good accuracy. A few of the important references about 'Acquisition in PLL¹' have been cited above and a more detailed list of references has been presented elsewhere¹⁰.

In the absence of noise, the pull-in time of an unaided PLL is proportional to the square of Δf , the frequency detuning⁶. The acquisition behaviour of a second order PLL in the absence of noise using the aiding function $e(t) = Dt$ has been studied⁴. The quasistationary approach suggested by Richman² has been applied here to evaluate the dependence of t_{ac} on the sweeping rate and relevant system parameters. Besides the analytical study, several techniques⁷ have been reported for the minimization of t_{ac} . Among them, the following five approaches are more useful.

2.1. Sweep method

A block schematic of this method⁶ is shown in fig. 1. The V.C.O. is tuned by applying a ramp voltage either manually or *via* a computer, which searches the input frequency. The ramp voltage can be applied at the V.C.O. input as shown, or obtained from a step voltage at the L.P.F. input. The direction of the sweep has to be periodically reversed and the sweep voltage has to be disabled after lock is achieved.

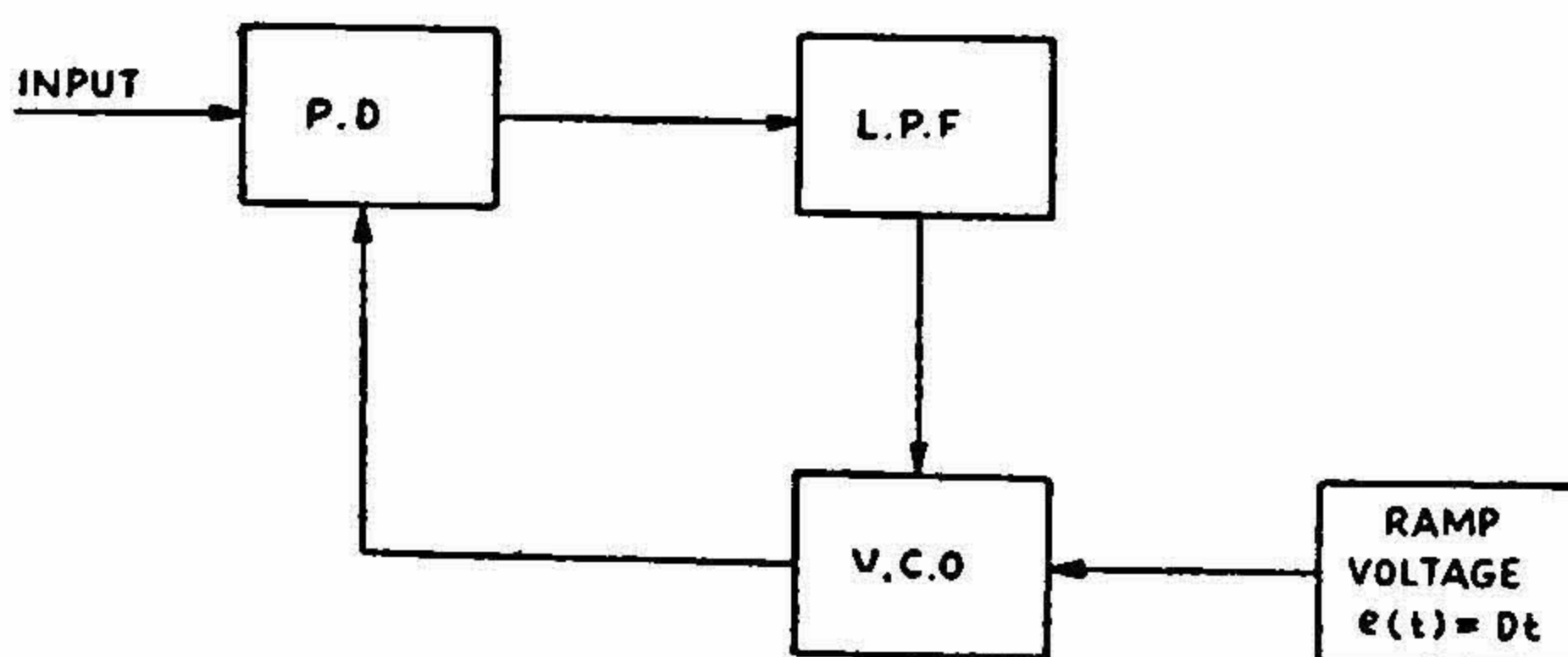

FIG. 1. Signal acquisition by Sweep method.

ACQUISITION TIME IMPROVEMENT OF PLL

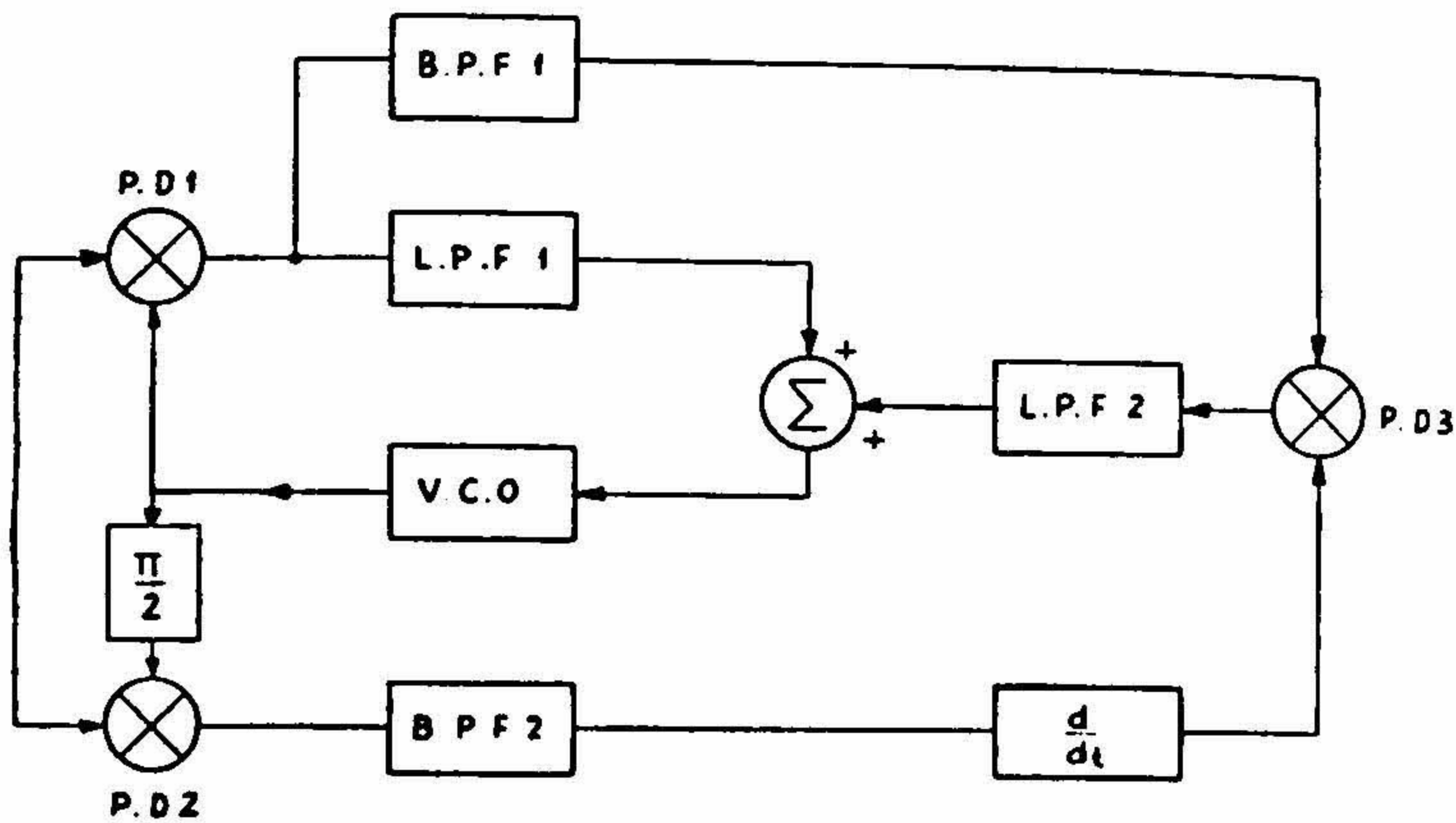

FIG. 2. Signal acquisition aided by frequency difference measurement.

2.2. Frequency difference technique

A block schematic of this method⁷ is shown in fig. 2. The P.D. outputs are band-pass filtered and heterodyned in P.D. 3, which provides a D.C. output voltage proportional to Δf with proper polarity. This D.C. voltage shifts the V.C.O. quiescent frequency suitably towards the incoming signal frequency. Due to the two-mode action, the noise bandwidth of the loop is made narrow enough for good locking without affecting acquisition. This method generally has poor performance at low input S/N ratios.

2.3. Wide bandwidth method

A block schematic of this method⁹ is shown in fig. 3. It employs two switchable bandwidth (wide/narrow) filters. The L.P.F. is brought into the feedback path of the loop by switching the resistance during acquisition/tracking mode by a suitable control signal. The transition should be smooth and during acquisition wide bandwidth will be successful only for large input S/N ratios.

2.4. Discriminator-aided acquisition

This uses a frequency discriminator in a conventional A.F.C. arrangement as shown⁸ in fig. 4. The multiple input active filter uses a damping resistor and all the damping is provided by the discriminator causing $\Delta\omega$ to decay exponentially. When $\Delta\omega$ decays to zero, the P.D. takes control and phase-lock overwhelms. This is a simple and effective method which takes care of the direction of $\Delta\omega$.

2.5. Quasi-stationary approach for aided acquisition

The quasi-stationary approach suggested by Richman² has been exploited by Russo *et al*⁴ for aided loops using a linear saw-tooth signal (*i.e.*, $e(t) = Dt$). A closed form

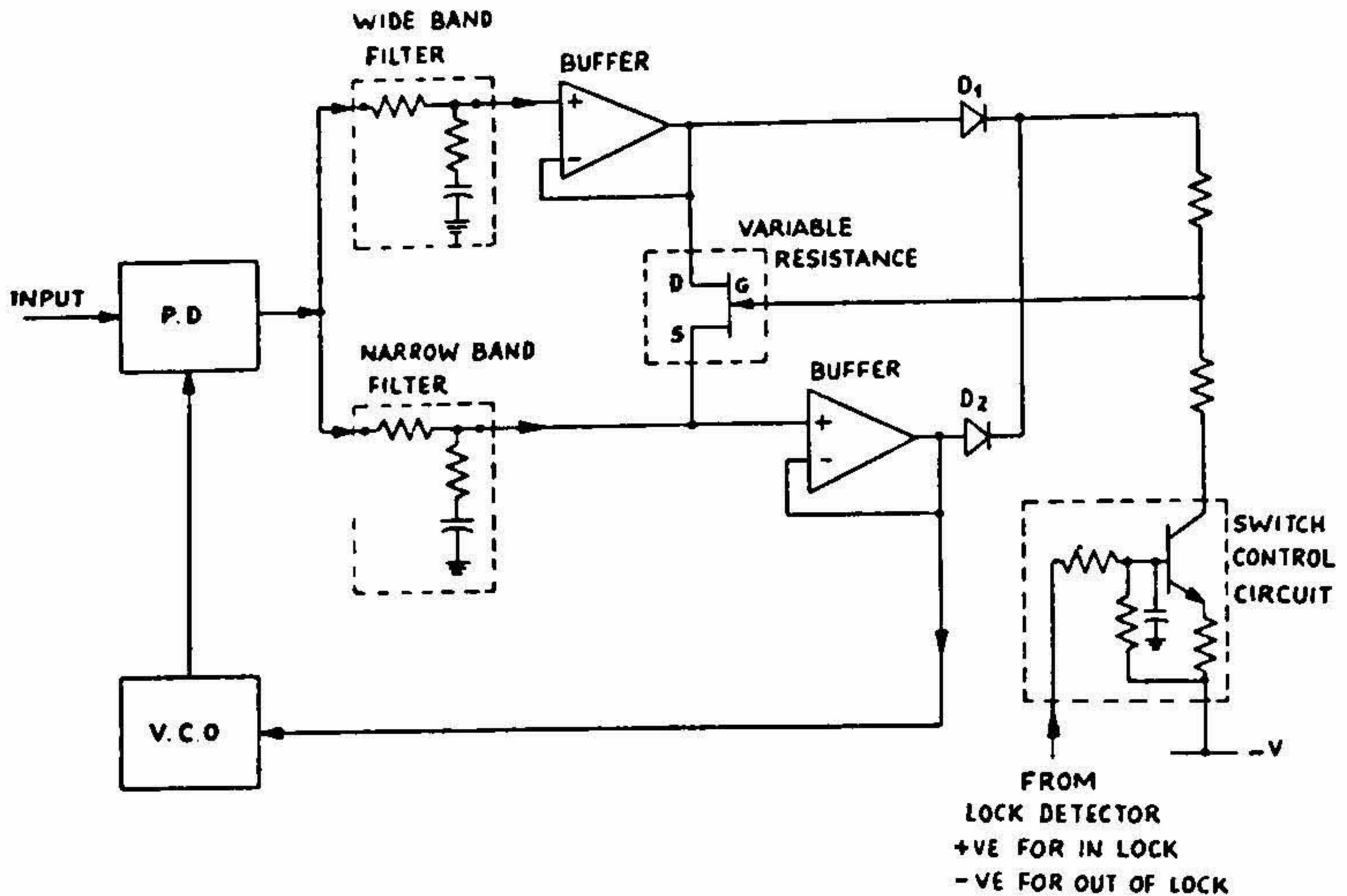

FIG. 3. Dual bandwidth PLL-circuit schematic.

solution for t_{ac} has been obtained with a considerable reduction in t_{ac} for higher sweep rates (within the maximum limits), using this approach.

The aiding techniques cited above do not seem to have been supported with analysis except in the case of discriminator-aided acquisition and quasi-stationary approach. Also though a closed form solution of aided acquisition of a PLL in the absence of noise has been reported using only a linear ramp type of aiding function, similar analysis for other types of aiding functions has not been reported. Besides, very little experimental work has been reported in support of aided acquisition. These factors are taken into account in the analytical and experimental work described in this paper.

3. Analytical study

It is clear from the above discussion that no effort seems to have been made towards the acquisition time minimization of PLL⁸ using aiding functions other than $e(t) = Dt$. Hence, it was decided to conduct a detailed investigation on the aided acquisition of a second-order PLL in the absence of noise, using some potentially useful aiding functions, such as $e(t) = Dt^2$, $e(t) = Dt^3$, $e(t) = D(1 - e^{-t/\tau})$, $e(t) = D(1 - e^{t/\tau})$, $e(t) = D(1 + e^{-t/\tau})$, $e(t) = D(1 + e^{t/\tau})$ and $e(t) = De^{t/\tau}$. These aiding functions have

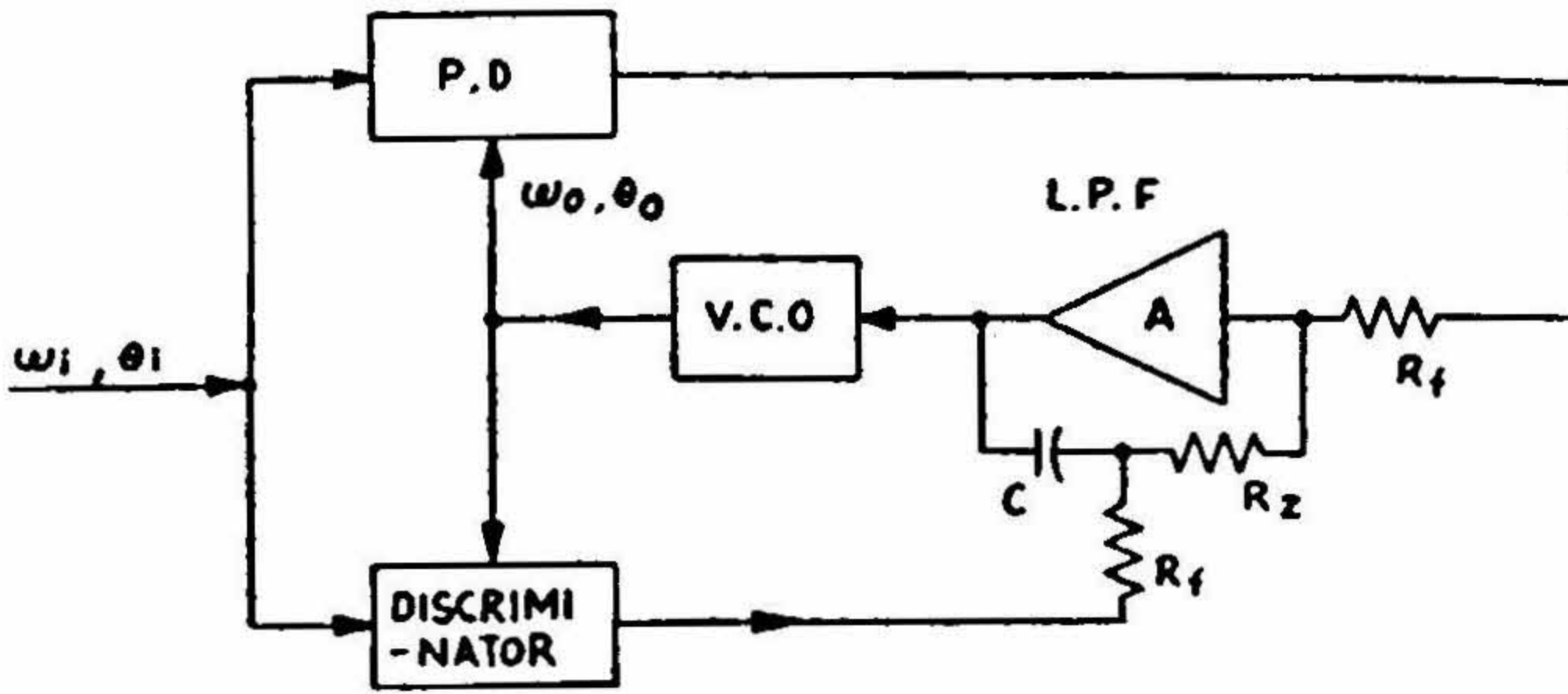

FIG. 4. Discriminator-aided acquisition for PLL.

been chosen with the premise, that when applied as input to the V.C.O., it should be possible to modify the V.C.O. output frequency to realize fast acquisition. Using these aiding functions with the PLL, closed form solutions have been obtained in each case by employing the quasistationary technique. It has been found from the analytical evaluation of the t_{ac} as well as from the experimental measurements, that the aiding functions $e(t) = Dt^2$ and $e(t) = Dt^3$ are the most useful ones. Therefore the discussion in this and the following sections is confined to the use of these functions.

In the absence of noise and with an imperfect integrator, the differential equation governing the PLL is given by,

$$S\dot{\phi} = \Omega_0 - AK_0 f(S) g(\phi) - K_0 e(t). \quad (1)$$

where, ϕ is the phase error, K_0 is the V.C.O. gain constant, A is the base band amplifier gain, $g(\phi)$ is the arbitrary periodic odd phase detector characteristic with a maximum value equal to 1, Ω_0 is the initial angular frequency detuning, $e(t)$ is the aiding function under consideration and $f(s)$ is the L.P.F. transfer function given by,

$$f(S) = \frac{1 + \tau_2 s}{1 + \tau_1 s} = f_0 + \frac{1 - f_0}{1 + \tau_1 s}. \quad (2)$$

Where, $\tau_1 = (R_1 + R_2) C$, $\tau_2 = R_2 C$, $f_0 = \frac{\tau_2}{\tau_1}$ the high frequency component. Breaking $f(s)$ into high frequency components, with its remainder corresponding to an L.P.F., the equivalent base band model of a PLL from eqn. (1) can be written as,

$$S\dot{\phi} = \omega_i - AK_0 f_0 g(\phi) \quad (3)$$

where, ω_i the instantaneous angular frequency difference impressed on the first order PLL shown in fig. 5 is given by

$$\omega_i = \Omega_0 - AK_0 g(\phi) \frac{1 - f_0}{1 + \tau_1 s} - K_0 e(t). \quad (4)$$

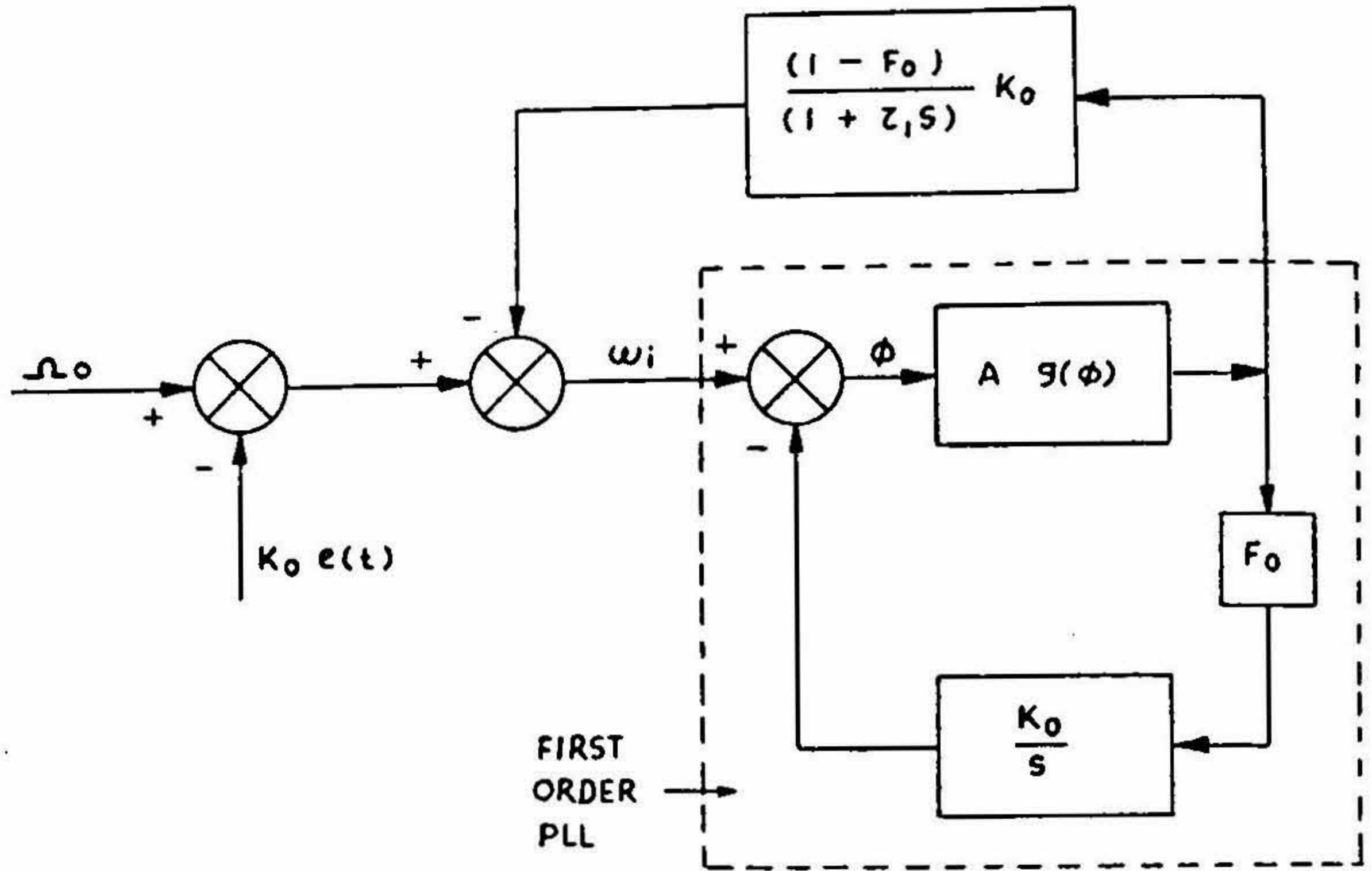

FIG. 5. Equivalent base-band model of PLL—block schematic.

In order to apply the quasistationary analysis, ω_i may be considered constant over the time interval of the order of the beat note period (T_b) relative to the fundamental frequency of the P.D. output. Under this assumption, the sweep rate is much smaller than $1/T_b$. Consequently a second order loop may be examined as a first order loop as shown in fig. 5, with an input average frequency $\bar{\omega}_i$, which is given by

$$\bar{\omega}_i = \Omega_0 - \frac{1-f_0}{1+\tau_1 s} \cdot AK_0 \overline{g(\phi)} - K_0 e(t) \quad (5)$$

where, the average P.D. characteristic

$$\overline{g(\phi)} = \langle g^2(\phi) \rangle \frac{AK_0 f_0}{\bar{\omega}_i},$$

for $\frac{\bar{\omega}_i}{AK_0 f_0} \gg 1$ and, $\langle g^2(\phi) \rangle$ is the average over the interval $-\pi < \phi < +\pi$.

For the aiding functions $e(t) = Dt^2$ and $e(t) = Dt^3$, the differential equations corresponding to eqn. (5), are given respectively by eqns. (6) and (7) :

$$\tau_1 \frac{d\bar{\gamma}}{dt} = \gamma_0 - \bar{\gamma} - \frac{1-f_0}{f_0 \bar{\gamma}} \langle g^2(\phi) \rangle - a(t^2 + 2\tau_1 t) \quad (6)$$

$$\tau_1 \frac{d\bar{\gamma}}{dt} = \gamma_0 - \bar{\gamma} - \frac{1-f_0}{f_0 \bar{\gamma}} \langle g^2(\phi) \rangle - a(t^3 + 3\tau_1 t^2) \quad (7)$$

where

$$\gamma_0 = \frac{\Omega_0}{AK_0 f_0}, \quad \bar{\gamma} = \frac{\bar{\omega}_t}{AK_0 f_0}, \quad a = \frac{K_0 D}{AK_0 f_0}.$$

Equations (6) and (7) are nonlinear differential equations having no exact solution. Therefore, in each case, using the method of variation of parameters by which the nonlinear term is removed, the remaining linear equation is solved. What follows next is given for the aiding function $e(t) = Dt^3$ only, as similar results can be obtained for the aiding function $e(t) = Dt^2$. Thus, the linear equation for the case of aiding function $e(t) = Dt^2$ is given by

$$\frac{d\bar{\gamma}}{dt} + \frac{\bar{\gamma}}{\tau_1} = \frac{\gamma_0}{\tau_1} - \frac{a_0}{\tau_1} (t^2 + 2\tau_1 t). \quad (8)$$

The solution of eqn. (8) is given by

$$\bar{\gamma} = \gamma_0 - at^2 + ce^{-t/\tau_1} \quad (9)$$

where C is an arbitrary constant of integration that must satisfy the initial condition $\bar{\gamma}(0) = \gamma_0$, and is allowed to become a function of independent variable, i.e., $C(t)$. Then the general solution is given by

$$\bar{\gamma} = \gamma_0 - at^2 + C(t) e^{-t/\tau_1}. \quad (10)$$

Substituting eqn. (10) in eqn. (8) and assuming $\gamma_0 \gg 1$ (large initial detuning),

$$\frac{dc(t)}{dt} + xyc(t) = x(1 + yat^2) e^{t/\tau_1}, \quad (11)$$

where,

$$x = \frac{(1-f_0) \langle g^2(\phi) \rangle}{f_0 \tau_1 \gamma_0}, \quad y = \frac{\beta}{\gamma_0} \text{ and } \beta \text{ is a coefficient determined on the basis}$$

of pull-in range.

With the initial condition $C(0) = 0$, the solution of eqn. (11) is given by:

$$C(t) e^{-t/\tau_1} = \frac{x}{d} \left\{ 1 + yat^2 + \frac{2yat}{d} + \frac{2ya}{d^2} - \left(\frac{2ya}{d^2} + 1 \right) e^{-at} \right\} \quad (12)$$

where,

$$d = (xy + 1/\tau_1).$$

With the pull-in range

$$\gamma_{0M} = \frac{2 \langle g^2(\phi) \rangle}{f_0}$$

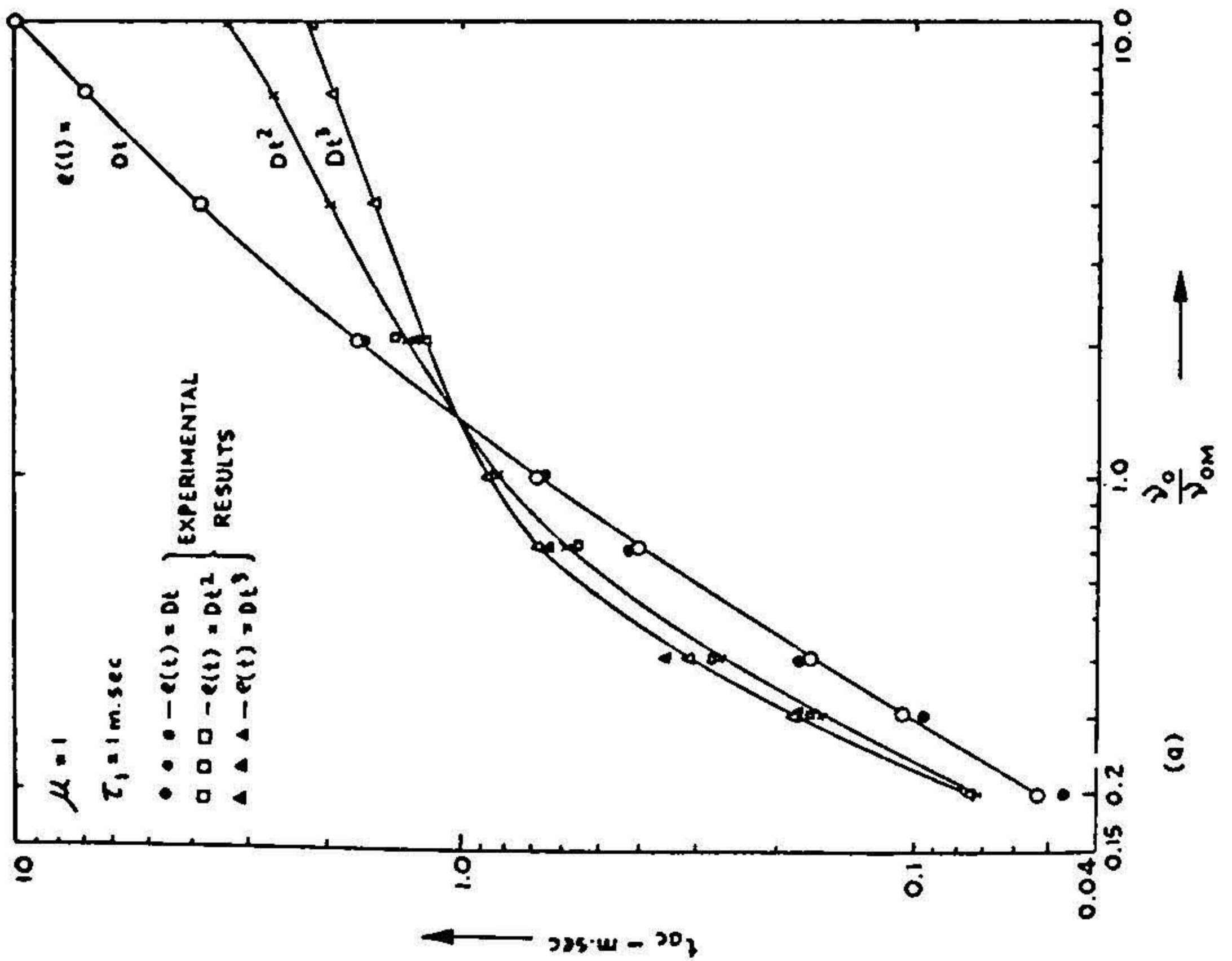
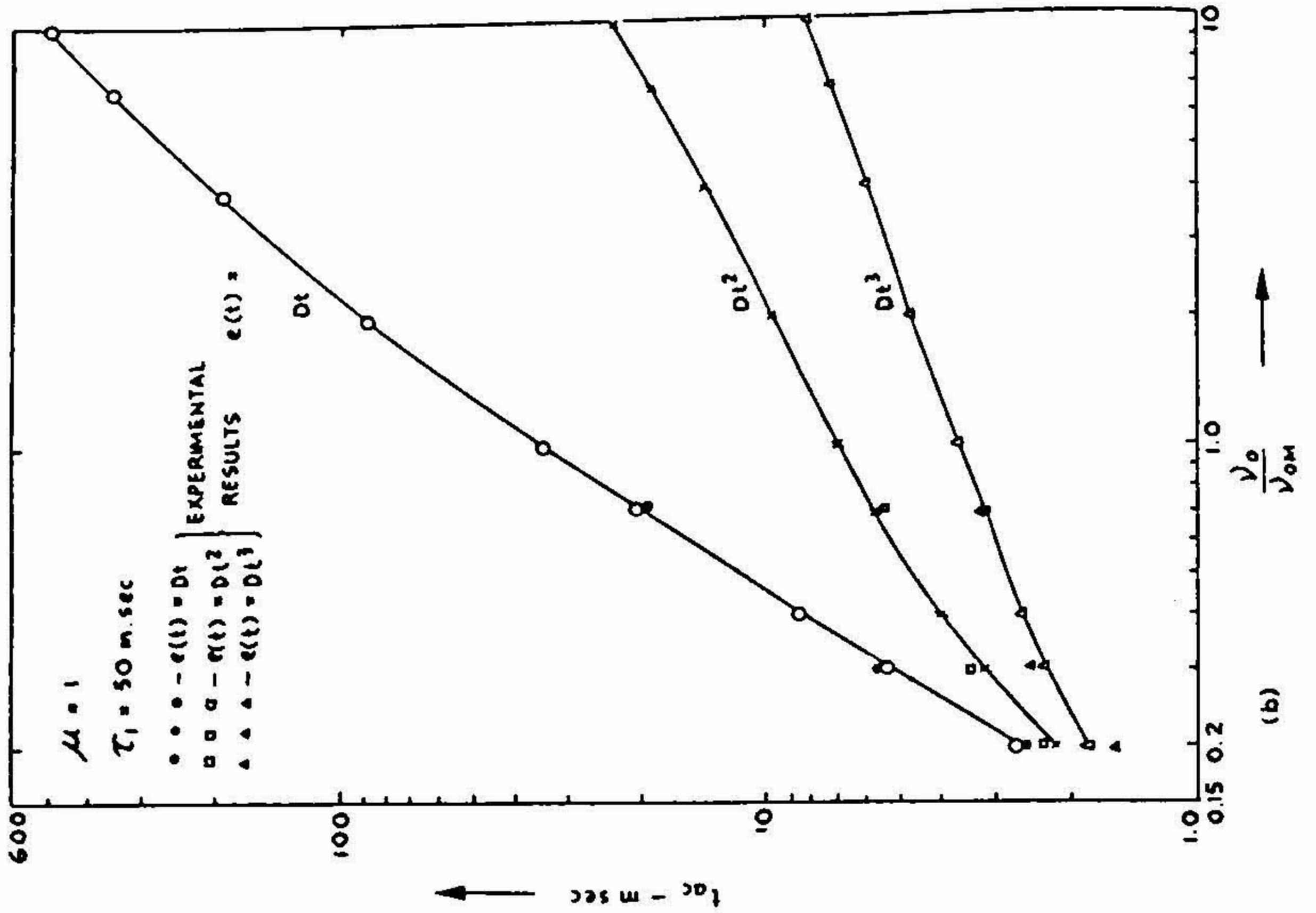

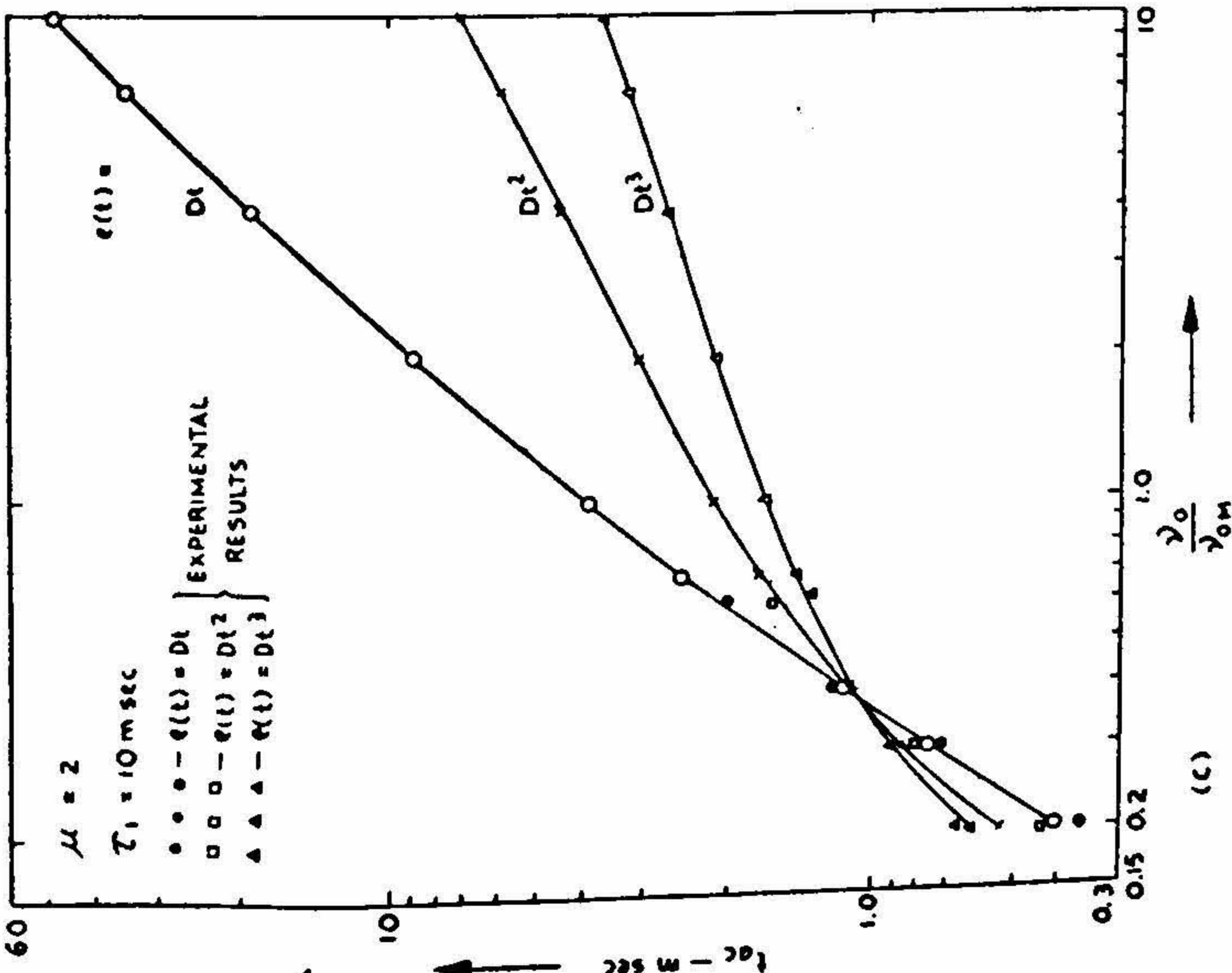
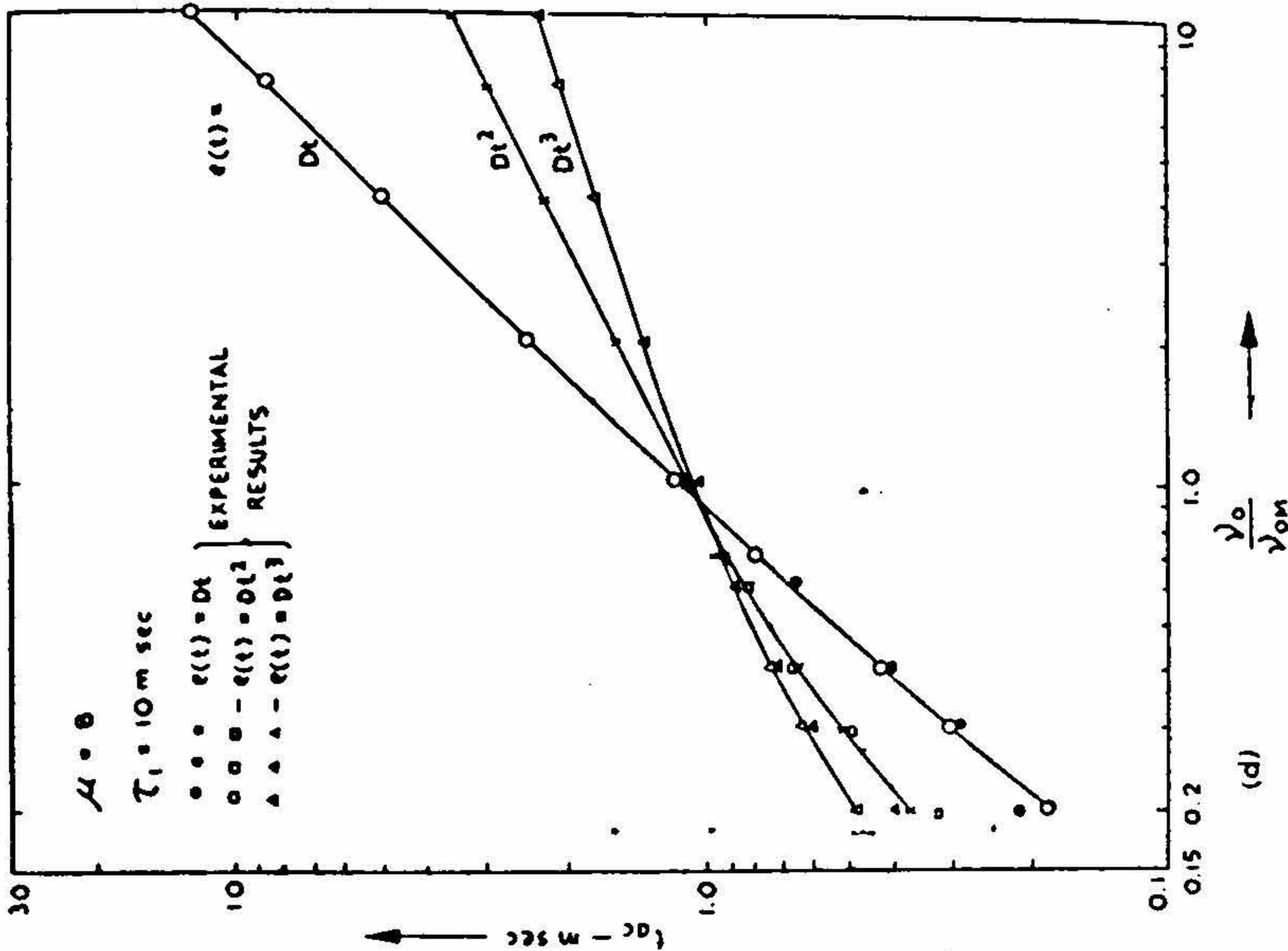

FIG. 6. Normalized frequency detuning (analytical and experimental results) vs. t_{ac} for aiding functions, $e(t) = Dt$, $e(t) = Dt^2$ and $e(t) = Dt^3$ for different values of μ and τ_1 .

and $f_0 \ll 1$, eqn. (9) becomes,

$$\bar{\gamma} = \gamma_0 - at^2 - \frac{1}{p} \left\{ \gamma_{0M}^2 \cdot \gamma_0 - \gamma_{0M}^2 \cdot \beta \cdot a \cdot t^2 + \frac{8\gamma_{0M}^2 \beta a \gamma_0^2 \tau_1 t}{p} + \frac{32 \gamma_{0M}^2 \beta a \gamma_0^4 \tau_1^2}{p^2} + \left(\frac{32 \gamma_{0M}^2 \beta a \gamma_0^4 \tau_1^2}{p^2} + \gamma_{0M}^2 \gamma_0 \right) \exp\left(\frac{-pt}{4 \gamma_0^2 \tau_1}\right) \right\} \quad (13)$$

where, $p = (4\gamma_0^2 - \beta\gamma_{0M}^2)$.

The frequency acquisition time t_{ac} (at $t = t_{ac}$) may be evaluated as the time required for $\bar{\gamma} \rightarrow 1$ from eqn. (13). Here the phase acquisition may be disregarded under the assumption of large detuning. Although in correspondence to the limit $\bar{\gamma} \rightarrow 1$, the initial assumption becomes invalid, the contribution to the acquisition time after $\bar{\gamma}$ has reached a few multiples of unity is negligible. For simplicity, the lower limit of $\bar{\gamma}$ is assumed to be zero. Using these conditions, eqn. (13) can be rewritten as

$$\frac{\mu\gamma_{0M}}{\gamma_0} \cdot \frac{t_{ac}^2}{\tau_1} + \frac{1}{m} \left\{ 1 + \beta\mu \frac{\gamma_{0M}}{\gamma_0} \cdot \frac{t_{ac}^2}{\tau_1} - 8\beta\mu \frac{\gamma_0^2}{\gamma_{0M}^2} \cdot t_{ac}/m + 32 \beta\mu \frac{\gamma_0^2}{\gamma_{0M}^2} \cdot \tau_1/m^2 - \left(32 \beta\mu \cdot \frac{\gamma_0^2}{\gamma_{0M}^2} \cdot \tau_1/m^2 + 1 \right) \cdot \exp\left(\frac{-m \cdot t_{ac}/\tau_1}{4 \gamma_0^2/\gamma_{0M}^2}\right) \right\} = 1 \quad (14)$$

where μ is related to the sweep rate of the aiding function and

$$m = \left(4 \frac{\gamma_0^2}{\gamma_{0M}^2} - \beta \right). \text{ As } t_{ac} \rightarrow \infty, \text{ for } \gamma_0 = \gamma_{0M}.$$

yields $\beta \approx 3$ from eqn. (14).

Proceeding on similar lines for the aiding function $e(t) = Dt^3$,

$$\begin{aligned} & \mu \frac{\gamma_{0M}}{\gamma_0} \cdot \frac{t_{ac}^3}{\tau_1} + \frac{1}{m} \left\{ 1 + \beta\mu \frac{\gamma_{0M}}{\gamma_0} \cdot \frac{t_{ac}^3}{\tau_1} - 12 \beta\mu \frac{\gamma_0}{\gamma_{0M}} \cdot t_{ac}^2/m \right. \\ & \quad + 96 \beta\mu \left(\frac{\gamma_0}{\gamma_{0M}} \right)^2 \tau_1 t_{ac}/m^2 - 384 \beta\mu \left(\frac{\gamma_0}{\gamma_{0M}} \right)^5 \tau_1^2/m^3 \\ & \quad \left. + \left(384 \beta\mu \left(\frac{\gamma_0}{\gamma_{0M}} \right)^5 \tau_1^2/m - 1 \right) \exp\left(\frac{-m \cdot t_{ac}/\tau_1}{4 \gamma_0^2/\gamma_{0M}^2}\right) \right\} = 1. \end{aligned} \quad (15)$$

For the sake of comparison, an evaluation of t_{ac} has also been made in the case of aiding function $e(t) = Dt$, using the following equation⁴:

$$\begin{aligned} & \mu \frac{\gamma_{0M}}{\gamma_0} \frac{t_{ac}}{\tau_1} + \frac{1}{m} \left\{ 1 + \beta\mu \frac{\gamma_{0M}}{\gamma_0} \left(\frac{t_{ac}}{\tau_1} - \frac{4}{m} \right) \right. \\ & \quad \left. - \left(\frac{1 - 4 \beta\mu \gamma_0/\gamma_{0M}}{m} \right) \exp\left(\frac{-m \cdot t_{ac}/\tau_1}{4 \gamma_0^2/\gamma_{0M}^2}\right) \right\} = 1. \end{aligned} \quad (16)$$

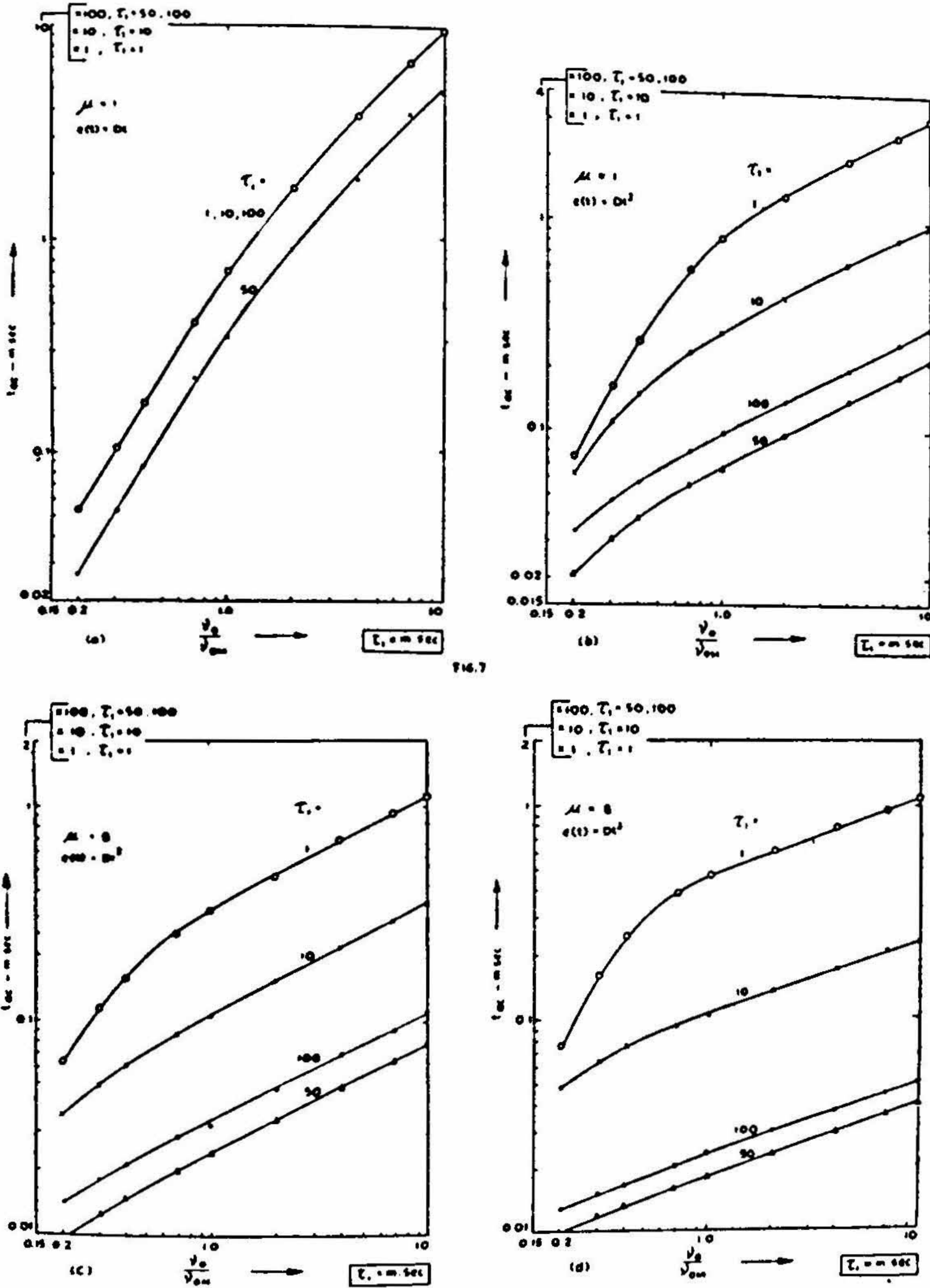

FIG. 7

FIG. 7. Normalized frequency detuning (analytical results) vs. t_{ac} for different values of τ_1 for aiding functions $e(t) = Dt$, $e(t) = Dt^2$ and $e(t) = Dt^2$ for $\mu = 1$ and $\mu = 8$.

When there is no aiding function introduced in the loop, *i.e.*, $\mu = 0$, it is interesting to see that eqns. (14)-(16) reduce to

$$\frac{1}{m} \left\{ 1 - \exp \left(\frac{-m}{4\gamma_0^2/\gamma_{0M}^2} \cdot \frac{t_{ac}}{\tau_1} \right) \right\} = 1. \quad (17)$$

Employing a numerical method and a digital computer¹⁰, the value of t_{ac} is evaluated for aiding functions $e(t) = Dt^2$ and $e(t) = Dt^3$ using eqns. (14) and (15) respectively and compared with that obtained for the aiding function $e(t) = Dt$. Some results obtained from the analytical evaluation in each case are shown in figs. 6 and 7 for different sweeping rates μ and L.P.F. time constants τ_1 . The following inferences can be drawn from these studies:

(i) The aiding functions $e(t) = Dt^2$ and $e(t) = Dt^3$ are observed to yield improved performance over the aiding function $e(t) = Dt$. The improvement is particularly more significant in the case of aiding function $e(t) = Dt^3$. This point can be more clearly seen from the graphs in fig. 6.

(ii) As the L.P.F. time constant (τ_1) is increased, the improvement becomes more and more significant in the case of aiding signals $e(t) = Dt^2$ and $e(t) = Dt^3$ over $e(t) = Dt$. This point can be more clearly seen from the graphs in fig. 7.

(iii) As the sweep rate (μ) is increased, t_{ac} decreases in all cases ($e(t) = Dt/Dt^2/Dt^3$), but the improvement is more pronounced in the case of $e(t) = Dt$ over $e(t) = Dt^2$ and $e(t) = Dt^3$. This is probably due to the fact that the voltage build-up is sharper (before the commencement of the subsequent cycle of the aiding function) in the case of $e(t) = Dt^2$ and $e(t) = Dt^3$, due to which the frequency variation of V.C.O. will not be able to follow up.

(iv) All these aiding functions, *viz.*, $e(t) = Dt$, $e(t) = Dt^2$ and $e(t) = Dt^3$ can be easily generated using conventional hardware and used to improve t_{ac} of the PLL.

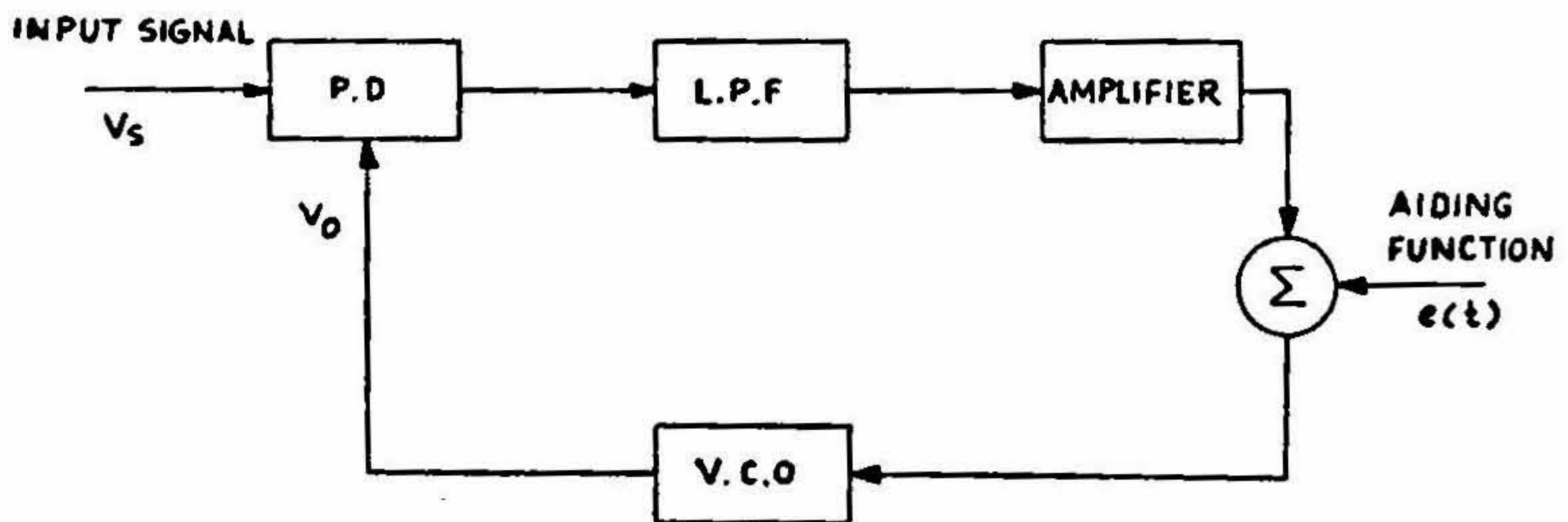

FIG. 8. Experimental set-up; block schematic.

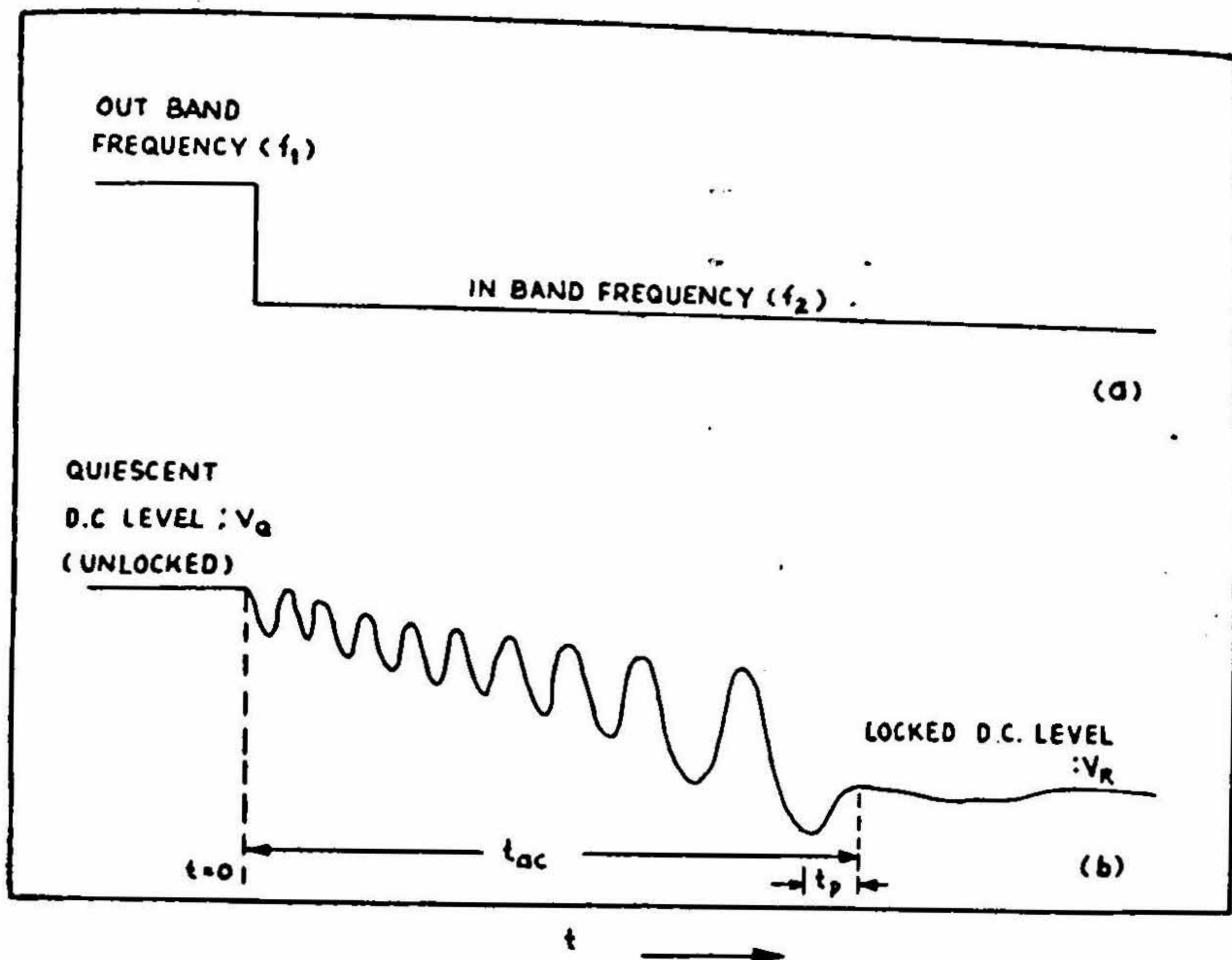

FIG. 9. (a) Input switching signal and (b) LPF output waveforms.

4. Experimental work

In order to verify the analytical results of the previous section, experiments have been conducted by developing suitable hardware using commercially available PLL⁸ and other components. As the present application is to study the acquisition behaviour of the aided second order PLL, suitable aiding functions are required to be introduced in the feedback path of the loop. This is shown in the block diagram of the experiment in fig. 8.

4.1. Acquisition time measurement technique

The acquisition time t_{ac} for large Δf has been defined as the time interval required for the PLL to achieve frequency lock after the input carrier is applied (Here, the phase-lock time (t_p) is assumed to be very small compared with t_{ac} for large Δf as shown in fig. 9). The t_{ac} can be measured by using either of the two methods as indicated below:

(i) From L.P.F. output transient

When the PLL input is changed from 'outband' frequency (f_1) to 'inband' frequency (f_2) at time $t = 0$ as shown in fig. 9 (a), the L.P.F. output changes from a quiescent

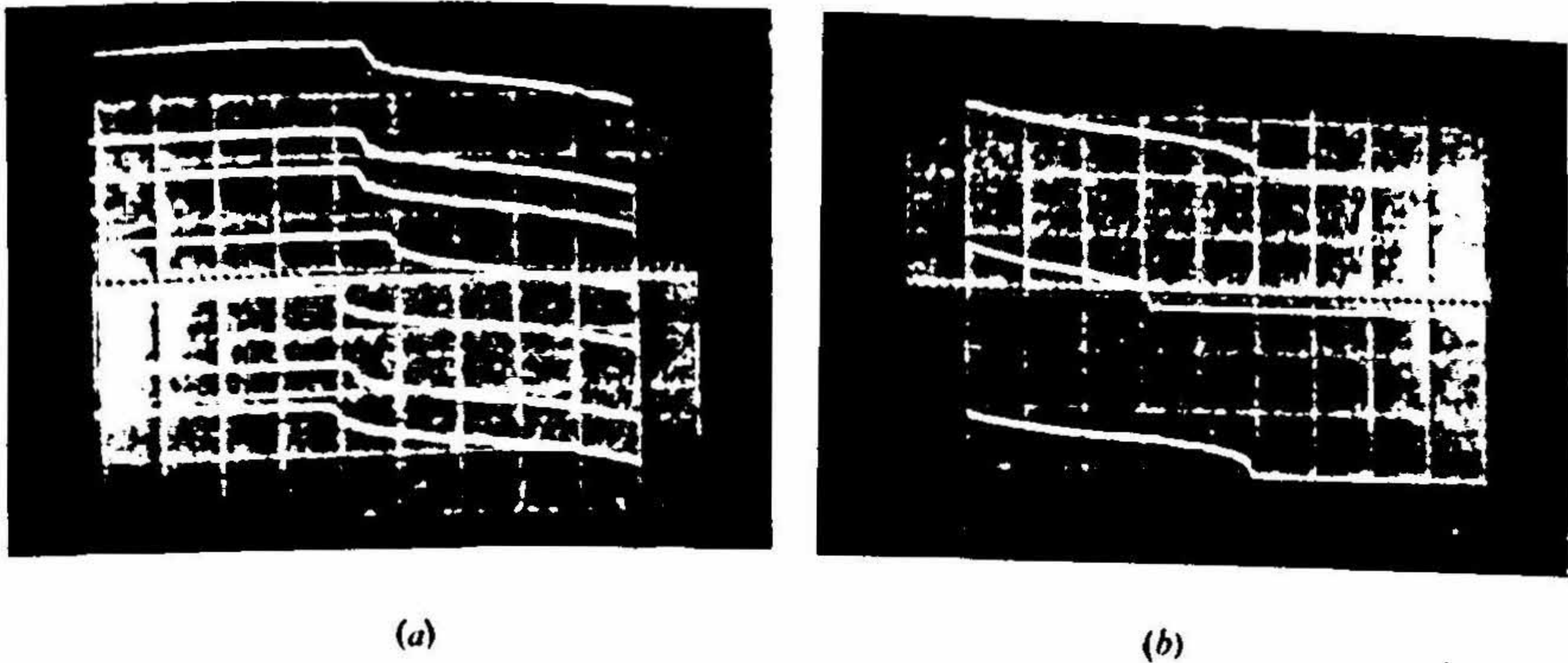

FIG. 11. CRO photographs of LPF output transient (a) for 7 trials with $\mu = 1$, $f_0 = 5$ KHz, $\Delta f = 97$ Hz, $\tau_1 = 50$ msec using aiding function $e(t) = Dt^3$. x axis 0.5 msec/div.; Y axis = 0.2 v/div. (b) for different functions with $\tau_1 = 50$ msec, $\mu = 1$. Upper trace : $e(t) = Dt^3$ (X axis = 0.5 msec/div) Middle trace : $e(t) = Dt^2$ (X axis = 1 msec/div). Lower trace : $e(t) = Dt$ (X axis = 1 msec/div). In all the cases : Y axis = 0.2 v/div.

ment is repeated at least 100 times and averaged. A sample of these results obtained from experimental measurements is shown in fig. 6 (superimposed over the analytical result graphs). Figure 11 shows the L.P.F. output transient oscillograms (using Tektronix type 314 storage CRO) for repeated trials. From these results, it is clear that experimental work carried out in the laboratory supports the analytical evaluation.

5. Concluding remarks

With the help of quasistationary approach, a second order PLL aided by different aiding functions has been analysed to study its acquisition behaviour in the absence of noise and the analytical results have been experimentally verified. The acquisition time plots show improved minimization of t_{ac} with the aiding functions $e(t) = Dt^2$ and $e(t) = Dt^3$ over $e(t) = Dt$. The salient features of this study are as follows:

- (i) A closed form solution is obtained for the evaluation of t_{ac} using different aiding functions;
- (ii) The aiding signal generation is simple and economical, and it can use state-of-the-art hardware;
- (iii) The measurement techniques for t_{ac} are simple and capable of yielding repeatable results.

It is expected that PLL's with improved acquisition time performance can be realized easily following the approach indicated in this paper. While it is of interest to note that the analysis presented here is for an aided PLL in the absence of noise, the

studies reported in literature¹¹ reveal that there exists a noise level that will be neither excessively large nor small to minimize the worst-case value of t_{ac} . This is suggestive that the acquisition behaviour of an aided PLL in the presence of noise is likely to show a considerable improvement of t_{ac} . This is being deferred for a separate investigation.

Acknowledgements

The authors express their grateful thanks to the Chairman, ECE Department, Indian Institute of Science, Bangalore, for providing facilities to carry out this research work. Thanks are also due to the Director of Technical Education, Government of Karnataka, Bangalore, and the Principal, College of Engineering, Gulbarga, for deputing one of the authors (YV) for research work under Q.I.P.

References

1. VITTERBI, A. J. *Principles of coherent communication*, McGraw-Hill Book Company, New York, 1966.
2. RICHMAN, D. Colour carrier reference phase synchronization accuracy in NTSC colour television, *Proc. Instn. Radio Engrs.*, 1954, 42, 106-133.
3. MEER, S. A. Analysis of phase locked loop acquisition—A quasi stationary approach, *IEEE Int. Conv. Rec.*, 1966, 14, Pt. 7, 85-106.
4. RUSSO, F. AND VERRAZZANI, L. Acquisition of a second order aided PLL, *IEEE, Trans. Aerosp. Electron. Systems*, 1979, AES-13, 17-21.
5. BISWAS, B. N. AND BANERJEE, P. Phase-locked loop acquisition for a noisy F.M. signal, *IEEE, Trans. Aerosp. Electron. Systems*, 1976, AES-12, 545-550.
6. GARDNER, F. M. *Phase-lock techniques*, John Wiley and Sons, Inc., New York, 1966.
7. LINDSEY, W. C. *Synchronization systems in communication and control*, Prentice Hall, Inc., New Jersey, 1972.
8. GARDNER, F. M. Acquisition of phase-lock, *Int. Conf. Communication, IEEE*, 1976, 10.1-10.5.
9. ANDERSON, A. T., SANDERS, D. E. AND GORDY, R. S. Dual bandwidth loop speeds phase-lock, *Electronics*, Jan. 9, 1975, 48, 116-117.
10. VENKATARAMAYYA, Y. *Acquisition time improvement of PLL^a using aiding functions—A study*, Ph.D. Thesis, Indian Institute of Science, Bangalore, 1979.
11. GOODMAN, S. L. Second order phase-lock loop acquisition time in the presence of narrow band Gaussian noise, *IEEE Trans. Commun.* 1973, COM-21, 297-300.