

THE DESIGN AND CONSTRUCTION OF A HIGH-SPEED ELECTRONIC DIFFERENTIAL ANALYZER

WIRING BY ~~NO CHANCE!!!~~ (BISWAS)

BY N. N. BISWAS, V. N. CHIPLUNKAR AND V. C. RIDEOUT

Department of Electrical Communication Engineering, Indian Institute of Science, Bangalore-3

Received April 15, 1955

I. INTRODUCTION

The past ten years have brought about a great growth in the types and uses of analog and digital computers. The chief impetus for this growth, as far as analog computers are concerned, has been provided by the needs of the aircraft industry, and the basic device which has made this growth possible has been the vacuum valve. However, computers are now used in nearly all industries as well as in fundamental research, and the transistor will soon supplement the vacuum valve as a basic device in computer construction.

The kinds of analog computers in use to-day include such devices as A-C network analyzers, potential analyzers, algebraic equation solvers, root-solvers, and most important of all, because of their general applicability, the various kinds of differential analyzers.

The first differential analyzer was a mechanical type of machine. It was built by V. Bush¹ at Massachusetts Institute of Technology and depended upon the Kelvin wheel-and-disc integrator as its basic and most important component. The size and cost of these machines led to a search for a cheaper and more compact machine which would do the same work. The invention by Lovell² of the operational amplifier using a *d-c* vacuum valve amplifier provided the basic unit which made possible the great recent growth in the number and uses of differential analyzers.

The operational amplifier, because it was invented during the war, was first used in special-purpose gun-sight computers. The general-purpose electronic differential analyzer,³ made up of a large number of operational amplifiers, was seized upon by the aircraft industry to enable preliminary studies of their airborne servomechanisms and autopilots to be made cheaply and safely in the computer laboratory. Rapid proliferation of its uses has followed so that it is now used to study such various phenomena as stability of atomic piles, speed regulation of turbo-alternators, springing of railway carriages and automobiles, and the characteristics of new kinds of non-linear servomechanisms, to mention just a few examples.

Messrs. 1. N. N. Biswas and 2. V. N. Chiplunkar, Research Assistants, 3. V. C. Rideout, Visiting Professor of Electrical Communication Engineering.

The electronic digital computer, which has also shown rapid growth since the completion of the ENIAC⁴ in 1949 should be briefly mentioned here, because it is often suggested that this type of general-purpose machine may completely supplant the analog machines.^{5, 6} The digital computer has the advantage that it is capable of great precision, because it works with digits, and furthermore its speed of operation (or machine complexity) may be traded for precision. The high precision of digital machines (12 decimal digit precision is common) cannot be matched by analog machines. Thus the mechanical differential analyzer is limited to about 0.1% precision, and the electronic differential analyzer to about 1% precision. However most engineering problems do not require high precision, because by the nature of these problems, data are not known to any high precision. Since the electronic differential analyzer has advantages over the general-purpose digital computers in initial cost, ease of problem set-up, and high speed of operation, it continues to find wide application.^{7, 8} Even the digital differential analyzer,⁹ a digital machine in which problems are set up as in analog types of differential analyzers, suffers from an initial cost disadvantage as compared to the analog type, and has a speed of operation too slow for certain unity-time-scale uses, as for example, in autopilot studies.

Perhaps the greatest advantage of the electronic differential analyzers results from the fact that in structure and behaviour they are so much like the device being studied that they are a real aid to the thinking of the scientist, engineer or inventor who uses them. This fact, together with the considerations of their low cost and easy maintenance, has led to their wide introduction into engineering college teaching and graduate research in the past few years.

II. BASIC PRINCIPLES OF THE ELECTRONIC DIFFERENTIAL ANALYZER

As mentioned above, the basic component in these machines is the operational amplifier,^{2, 3} which is simply a high-gain, direct-connected amplifier with added input impedance Z_i and feedback impedance Z_f as shown in Fig. 1 (a). The amplifier gain ($-A$) must be negative, for negative feedback. In this network, if we assume zero current flowing into the input grid of the amplifier, and the presence of a voltage $E_o = E_o/(-A)$ at this point, then, in operational form,

$$\frac{E_i - E_o}{Z_i} + \frac{E_o - E_o}{Z_f} = 0 \tag{1}$$

Thus if A is large,

$$E_o \approx - \left(\frac{Z_f}{Z_i} \right) E_i \tag{2}$$

If Z_f and Z_i are both resistive we have an amplifier or scale changer, as shown in Fig. 1 (b). Good precision and gain stability result from the fact that this scale changer constant Z_f/Z_i depends only upon passive element values.

If Z_f is capacitive and Z_i resistive, an integrator results, as shown in Fig. 1 (c). A differentiator (not shown) requires that Z_f be resistive and Z_i capacitive.

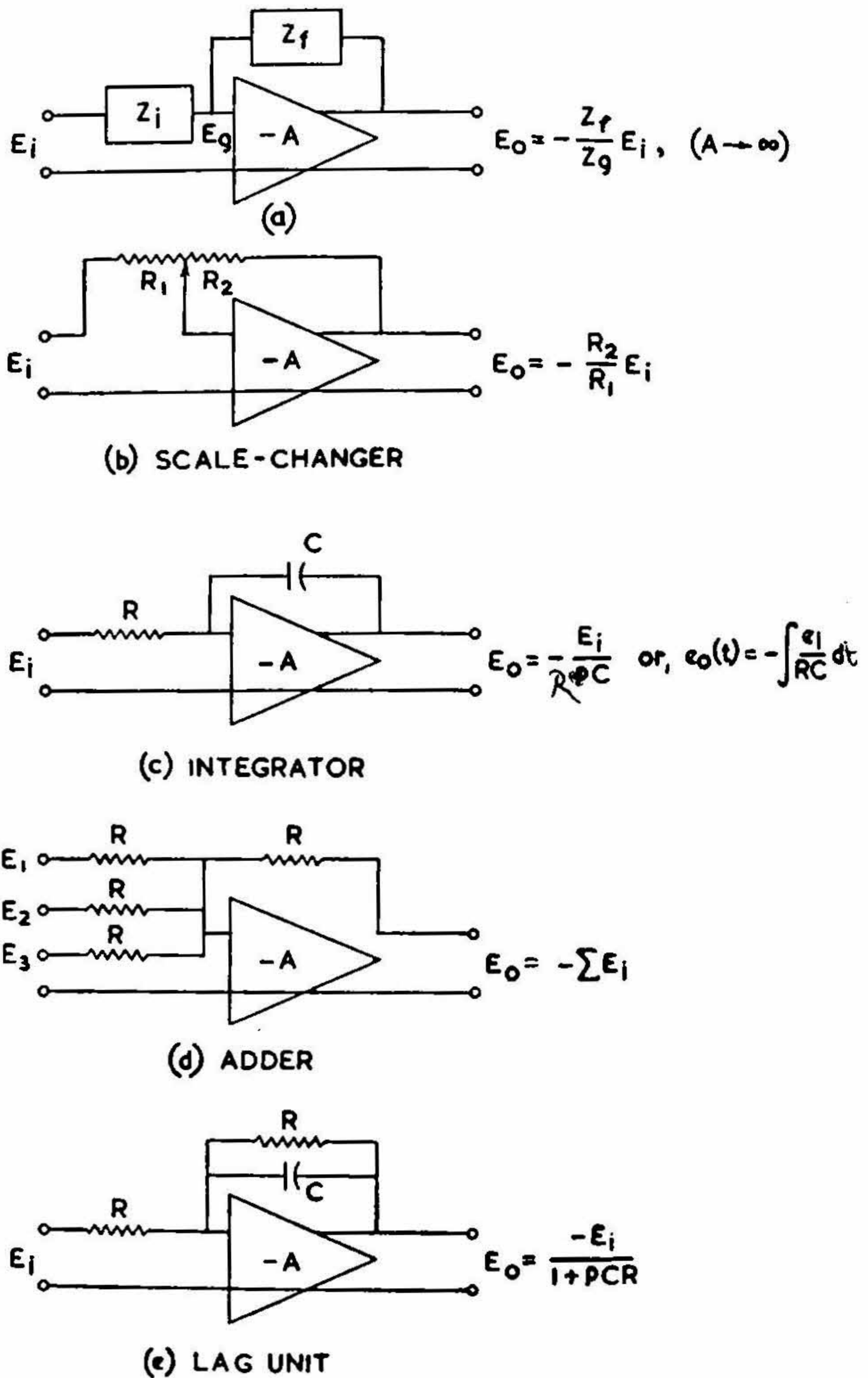

FIG. 1. Some mathematical operations possible with the operational amplifier.

The proof that adder operation results, if several inputs are used as shown in Fig. 1 (d), may be developed much as in the equations above.

Both Z_f and Z_i may be more complex combinations of resistance and capacitance (inductors are seldom used because of considerations of size, cost and limited Q), with the result that $-Z_f/Z_i$ is a more complex operator than in the

cases above. Thus if Z_1 is a parallel combination of resistance and capacitance, $Z_1 = R/(1 + pCR)$, and $Z_2 = R$ as shown in Fig. 1 (e), the resultant operation is $-1/(1 + pCR)$, a simple lag.

III. COMPUTER SOLUTION OF A SIMPLE LINEAR PROBLEM

Figure 2 (a) shows the diagram of a simple rotational-mechanical system, which, if linear operation is assumed, has the equation,

$$q(t) = J\ddot{\theta} + B\dot{\theta} + K\theta \quad (3)$$

Writing this equation with the highest derivative on the left and dividing throughout by J gives

$$\ddot{\theta} = \frac{q(t)}{J} - \frac{B}{J}\dot{\theta} - \frac{K}{J}\theta \quad (4)$$

To set up the computer for solution, assume we have the second derivative, and use an integrator and a scale changer as shown in Fig. 2 (b) to form $(B/J)\dot{\theta}$. A second integrator gives θ , and this may be changed to $(K/J)\theta$ by means of a potentiometer (but only if $K/J < 1$), or the coefficient may be set in the input resistor of the following adder as in Fig. 2 (b). The two quantities we now have, together with a voltage which varies as $-q(t)/J$ may be added together to give $\ddot{\theta}$, and complete the loop. If the voltage output of the second integrator is observed by means of an oscilloscope or a recorder it will indicate the transient angular response, θ . Similarly $\dot{\theta}$ and $\ddot{\theta}$ may be observed.

If resistors are in megohms and capacitors in microfarads the integrator time constants are each equal to one second and the computer is said to operate at unity time-scale. In this case a pen-type recorder or an oscilloscope with a very long persistence time must be used. If capacitors are smaller, say in millimicrofarads, operation is speeded up by 1000 times. The input waveform may then be applied repetitively, say once each 1/20 of a second, and the result observed on an ordinary oscilloscope. In this case, we have a repetitive or high-speed computer.^{8, 10, 11}

The extension of this method of computer solution to more involved linear problems is obvious. Of still greater value is the possibility of solution of non-linear problems in which backlash, limits, or multiplication of varying quantities is required. The solution of such problems, and the devices required will be discussed in a subsequent paper.

IV. GENERAL FEATURES OF THE DESIGN OF THE INDIAN INSTITUTE OF SCIENCE COMPUTER*

As a result of encouragement by the Director of the Institute and the Head of the Department of Electrical Communication Engineering, it was decided to

* Professor K. Sreenivasan has named this computer the PREDA (Philbrick-Rideout Electronic Differential Analyzer).

proceed with the building of an electronic differential analyzer as part of the duties of the senior author during his year's stay at the Institute as a TCM Visiting

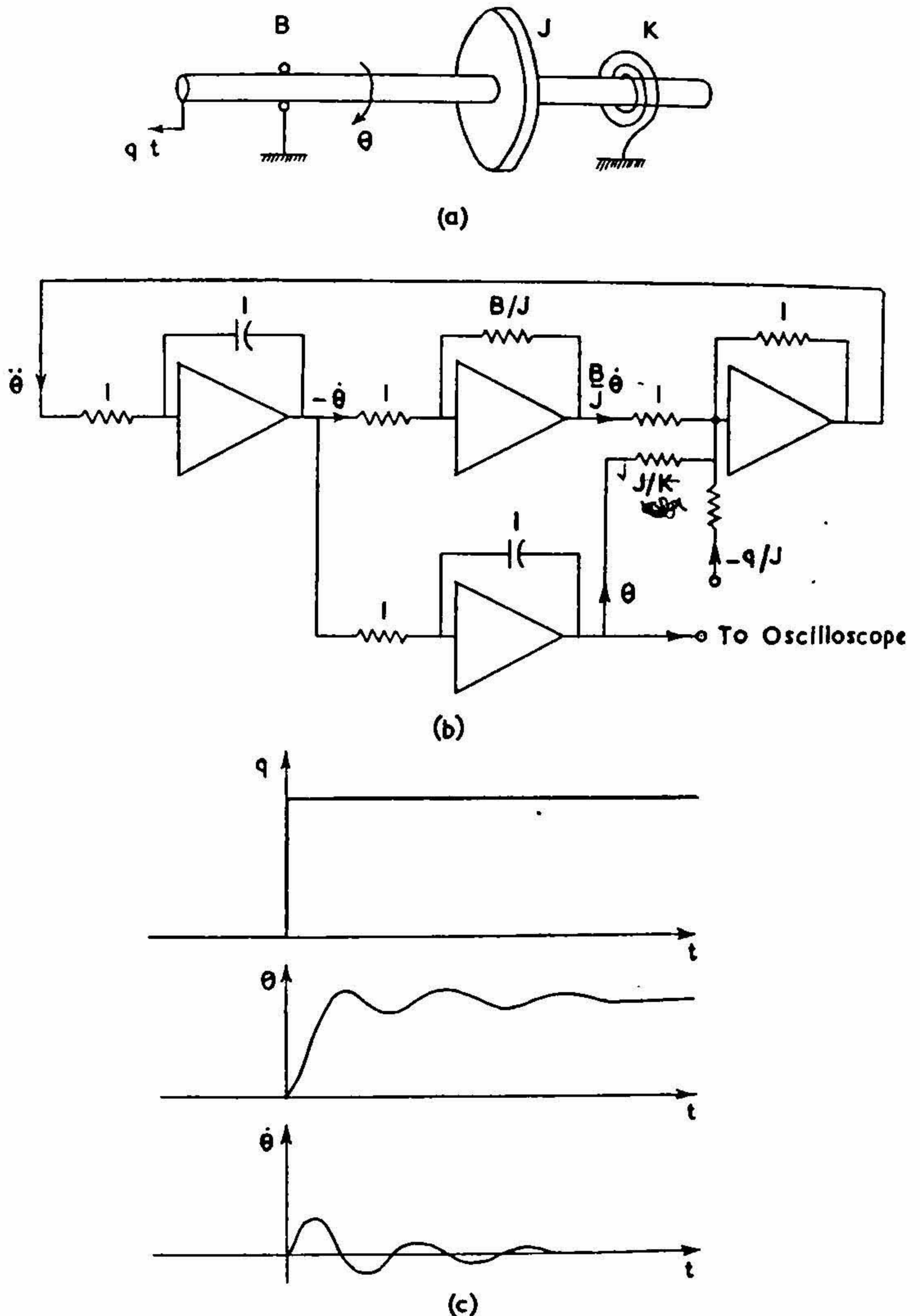

FIG. 2. (a) A simple linear mechanical system. (b) Computer set-up for solution of the equations representing the system of (a). (c) Input torque waveform and possible output waveforms for one case.

Professor. The decision to build, rather than to buy such a computer was based on the following considerations:—

(1) It was felt that the resultant very considerable reduction in cost would make it possible to get more computing equipment for the same outlay at the Institute. Other institutions would then more easily be able to follow suit if the design was shown to be satisfactory.

(2) In the process of construction much valuable information regarding computer design and operation could be gained by the personnel involved.

(3) This procedure would make it more readily possible to design new circuits and connection arrangements and thus advance the analog computing art.

It was decided to base the design on the use of Philbrick¹² plug-in operational amplifiers, and to make a high-speed repetitive type computer (which could, however, be operated at unity time-scale by merely changing all capacitor sizes).

The number of operational amplifiers in the unit was chosen as twenty, based partly on considerations of space and power supply capacity. This compares favourably with the twelve operational amplifiers supplied in the basic linear computer units retailed by a number of companies. Also, the operational amplifier connections are so arranged that each can be used for any purpose, a flexibility not possessed by all designs of computers, and one which makes possible more efficient use of a small number of operational amplifiers. It should be pointed out here that if a second computer, like the one described in this paper is built, the two units can either be used separately, or combined for the solution of more involved problems.

Ten precision potentiometers of the Helipot type were decided upon. Tektronix units are used for square wave generation and clamping, and a type 304-H Dumont oscilloscope for viewing solutions. Permanent recording of solutions is possible with the aid of an oscilloscope camera.

V. SOME DETAILS OF THE OVERALL COMPUTER DESIGN

(a) *Choice of time scale:* In a repetitive type of computer the repetition rate should be high enough to prevent undesirable flicker in the oscilloscope presentation of results. However, it should not be any higher than necessary, because errors due to phase-shift in the amplifiers may become troublesome.^{13, 14} Repetition rates as low as 25 per second are satisfactory with a P-1 oscilloscope phosphor, and even lower rates may be used if a P-7 long-persistence phosphor is used.

A favoured scheme is to provide, for general-purpose use in the computer, rectangular pulses which are 10 or 20 computer seconds in length, and which are separated by a similar time. With a choice of 1 computer sec = 0.0008 sec (or 0.8 millisecond), this gave a repetition frequency of 62.5 per second for the 10 csec pulse as shown in Fig. 3 (a), and 31.25 per second for the 20 csec pulse (and spacing). This does not cause troublesome oscilloscope flicker, and it is felt that the computer second might be further increased, at least to 0.001 sec.

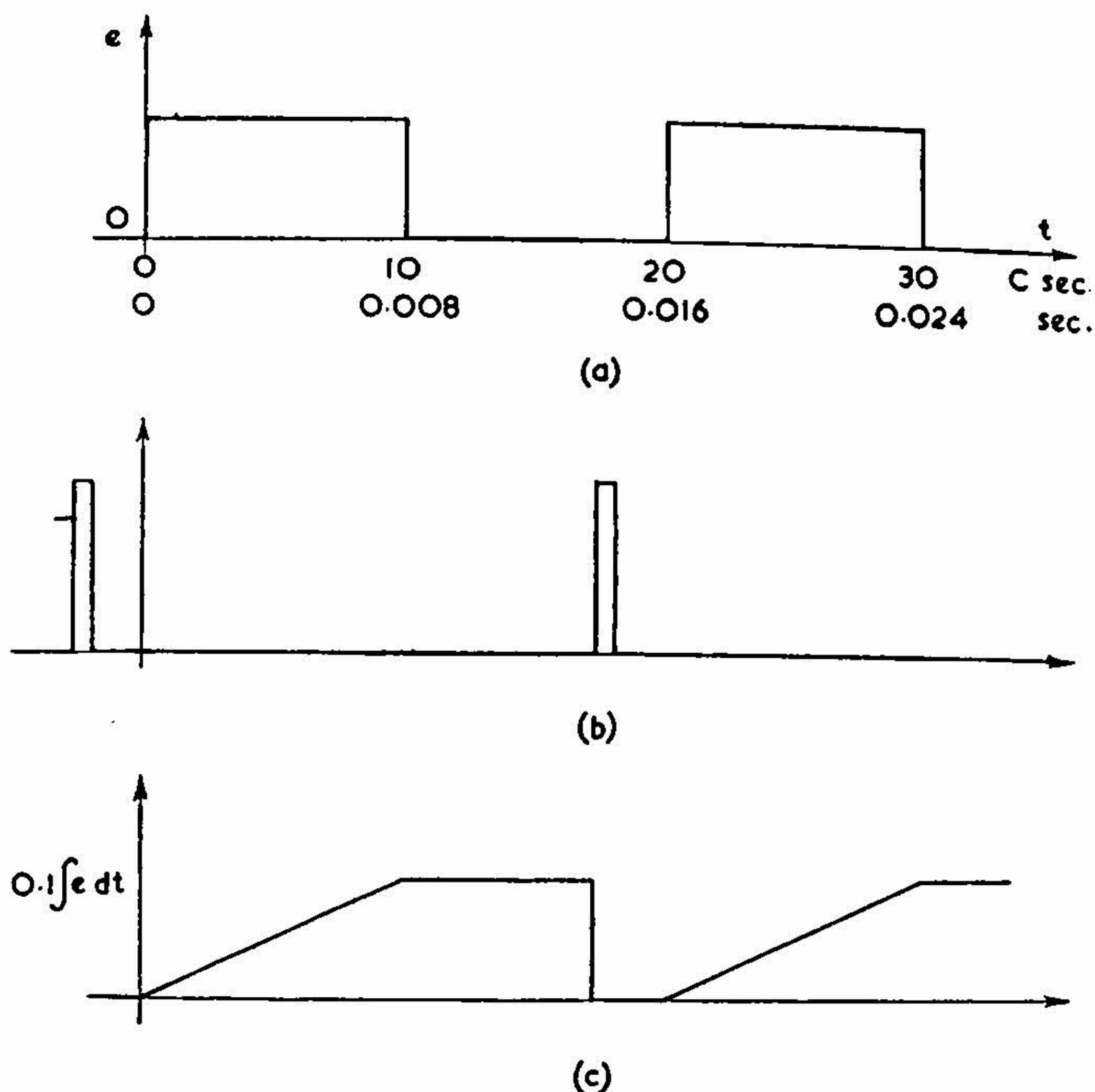

FIG. 3. (a) Standard square wave used for step-inputs and other purposes.
 (b) Clamping wave.
 (c) Integration of waveform (a) with a clamped integrator.

The computer "characteristic frequency" of one radian per computer second is thus $(\frac{1}{2}\pi) \times 0.0008$ or 199 c.p.s. If good operation of all computer components up to the 20th harmonic of this fundamental frequency is required, note that this highest frequency is only about 4000 c.p.s. Thus phase and amplitude characteristics¹⁴ need only be maintained at desired values through the lower audio frequencies.

(b) *Choice of mounting and connection panel facilities:* It was decided to make the mechanical construction of the computer conform to the standard telephone rack, so that standard panels and a convenient enclosed rack could be used. The overall result is as shown in the photograph of the completed computer in Fig. 4. Since individual units are fixed on the panels they cannot be arranged in any desired pattern on rack shelves or on tables as in the early Philbrick unit designs. This type of flexibility was not felt to be too necessary because each amplifier is of the general-purpose type and the result has been some saving in space.

(c) *Choice of connecting cords and connector hardware:* It was decided to use standard banana-jacks on the amplifier panels, and connecting cords equipped with banana-plugs, of the Addaplug type. These have proven quite satisfactory.

(d) *Choice of control waveform generator:* A pair of Tektronix waveform generators were chosen which would supply square waves such as the one shown in Fig. 3 (a). These generators also supplied a periodic pulse as shown in Fig. 3 (b), which could be positioned anywhere within the zero portion of the square wave and used for clamping of integrators. A sawtooth or ramp voltage is also available from these generators, or may be generated by an integrator as shown in Fig. 3 (c).

Precise timing requires that the computer seconds be marked off in some way, preferably by feeding sharp pulses, accurately spaced at 0.0008 seconds, into the Z-axis of the oscilloscope. A simple timing device has been designed and will be described in a subsequent paper.

(e) *Regulated power supplies:* Both +300 volts and -300 volts must be supplied to the operational amplifier. A regulated power supply is used to minimize zero-drift. To further minimize drift an A-C regulator is used between the mains and both the regulated power supply and the filament transformers.

VI. DETAILS OF DESIGN OF LINEAR COMPONENTS

(a) *Operational amplifier connections:* Figure 5 shows the operational amplifier connections, and Fig. 6 (a) and (b) are photographs of a typical chassis containing five amplifiers. The high-gain amplifiers used are Philbrick K2-W units. The first stage in this amplifier is a cathode-coupled stage, and the second grid of this stage is connected to a 5000 ohm rheostat for zeroing, as shown in Fig. 5.

Fig. 7 (a) shows the front panel plan of the banana-jack connections to each operational amplifier. The amplifier input is connected to jacks 4 and 7, and the output to 8 and 9. A standard double-banana-plug can be used to connect Z_1 between 7 and 8, while the same means may be used to connect Z_4 between 1 and 4 and/or between 5 and 4. In addition to 1 and 5, there are three other input jacks, 2, 3 and 6, with one-megohm resistors permanently connected.

A three-position double-pole switch [see photograph of panel, Fig. 6 (a) and connection diagram, Fig. 5] may be used to connect the commonly used one-megohm resistor as Z_1 , in the up position, and 5 megohms, 10 megohms, or a 0.0008 μf capacitor in the down position. In its centre position it is open, to permit Z_1 to be plugged in externally.

(b) *Provision for clamping of integrators:* In the solution of problems involving unstable or nearly unstable systems it is desirable to short out any voltage across the integrating capacitors before the beginning of each computing epoch. In real-time computers this may be accomplished with the aid of relays, but in high-speed computers a 12AU7 double triode, connected as shown in Fig. 5, provides a more rapidly acting switch or clamp. A pulse [see Fig. 3 (b)] obtained from the Type

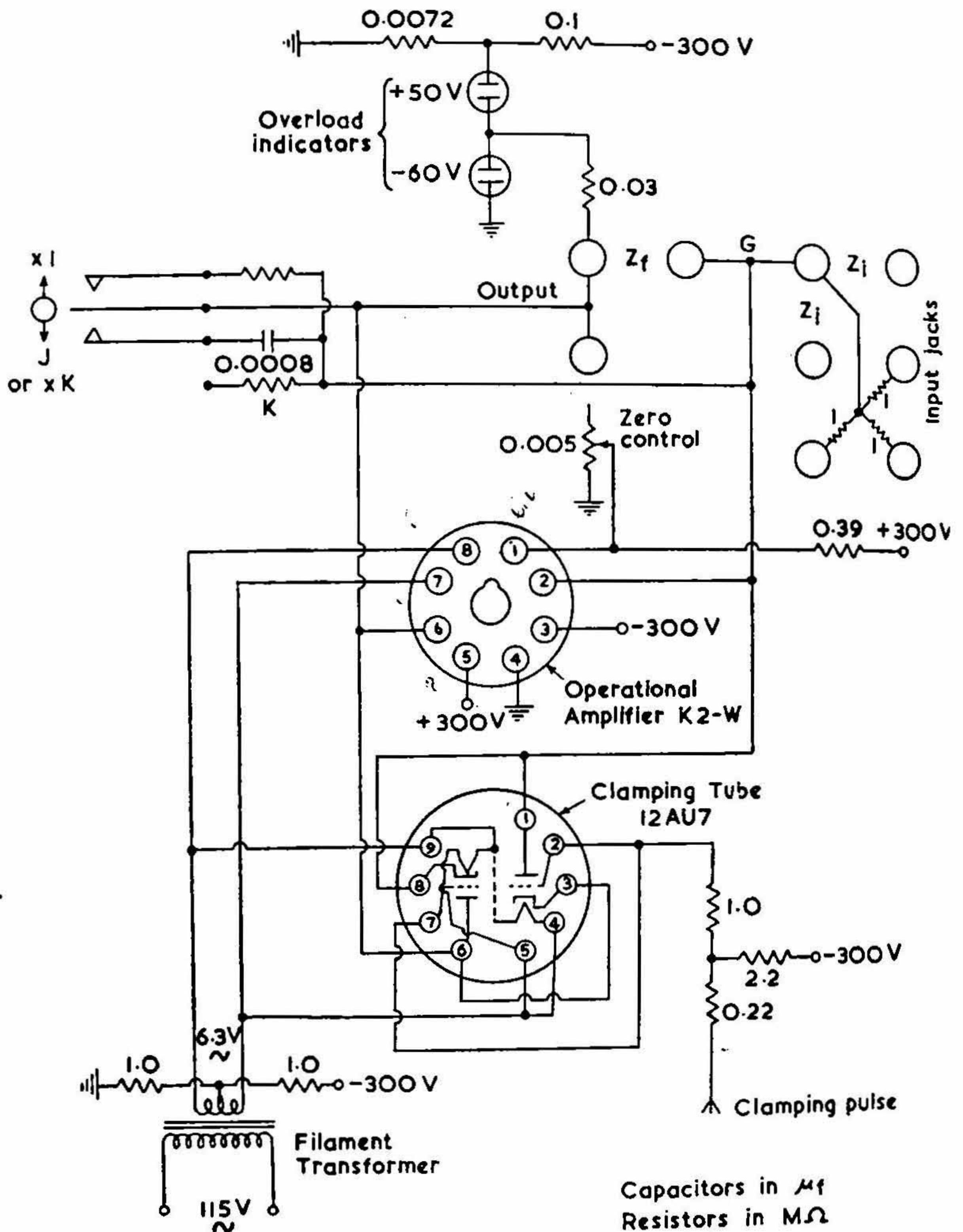

FIG. 5. Circuit connections to the K2-W plug-in operational amplifier.

162 Tektronix Waveform Generator during the off-time of the output square wave of the Type 161 unit, is applied to the grids of the 12AU7. (This clamping scheme follows the original design of G. A. Philbrick.)

Six of the twenty amplifiers have clamping tubes and also have provision for the switching-in of feedback capacitors of standard size.

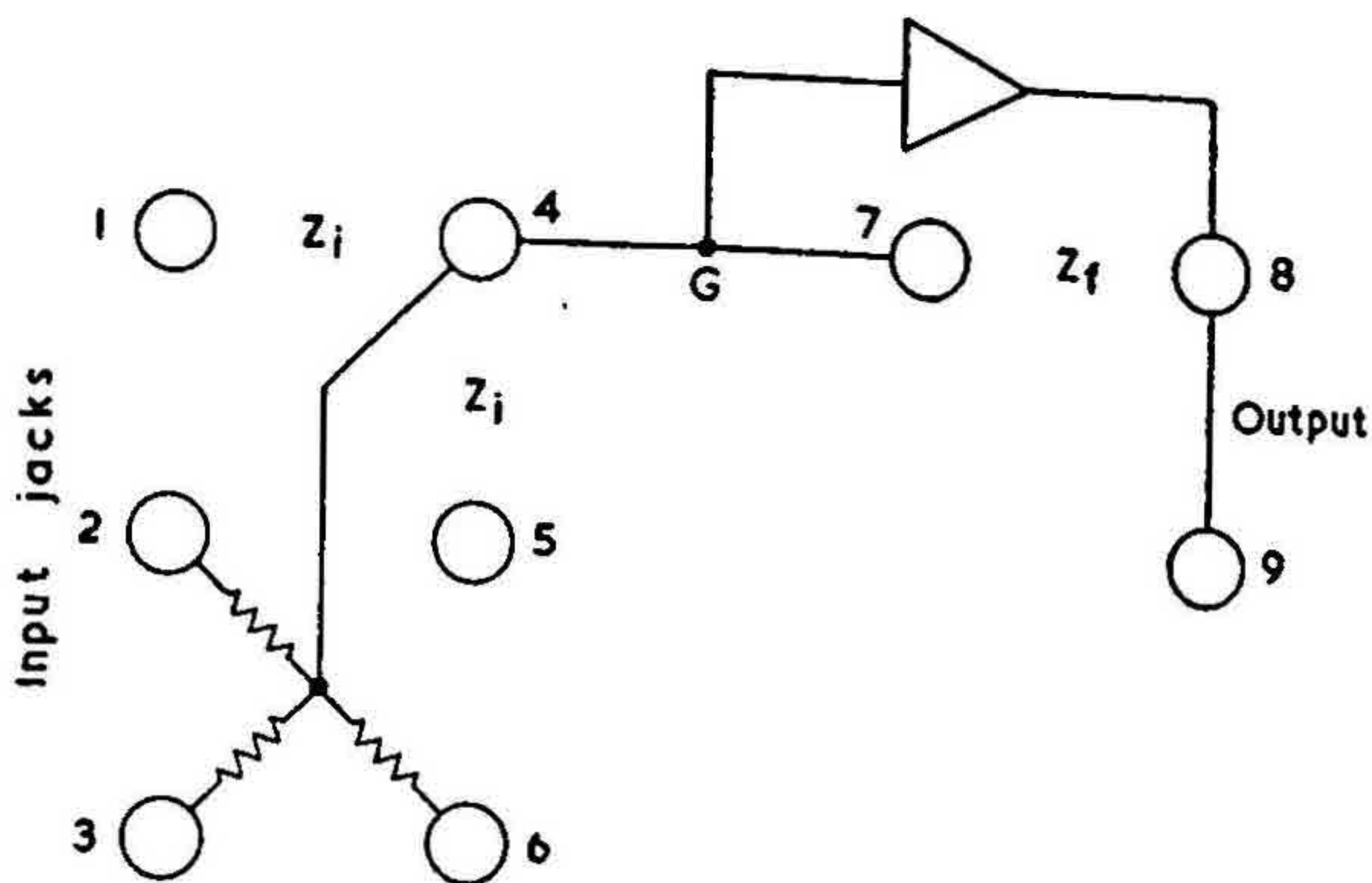

FIG. 7 (a)

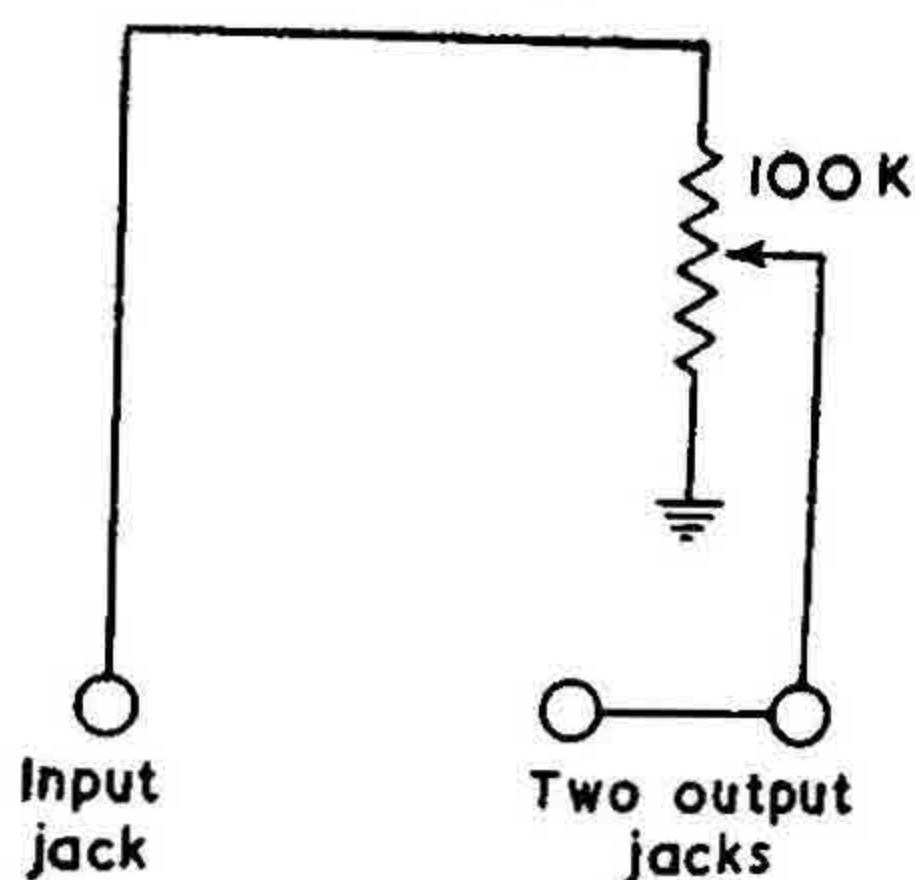

FIG. 7 (b)

FIG. 7. (a) Banana-Jack connections to each operational amplifier (front view).
(b) Banana-jack connections to the Helipot (front view).

(c) *Potentiometer panels:* The ten 0.1% precision Helipot are arranged in two panels with banana-jack connections to input and output, as shown in Fig. 7 (b). These potentiometers are each of 100,000 ohms impedance. Because loading reduces amplifier overload voltages, set-ups are usually planned so that not more than two potentiometers are driven by a single amplifier. Also, the loading-error must be taken into account⁸—even the one-megohm load of an amplifier with this size of Z_i can cause a maximum error of 1.5%.

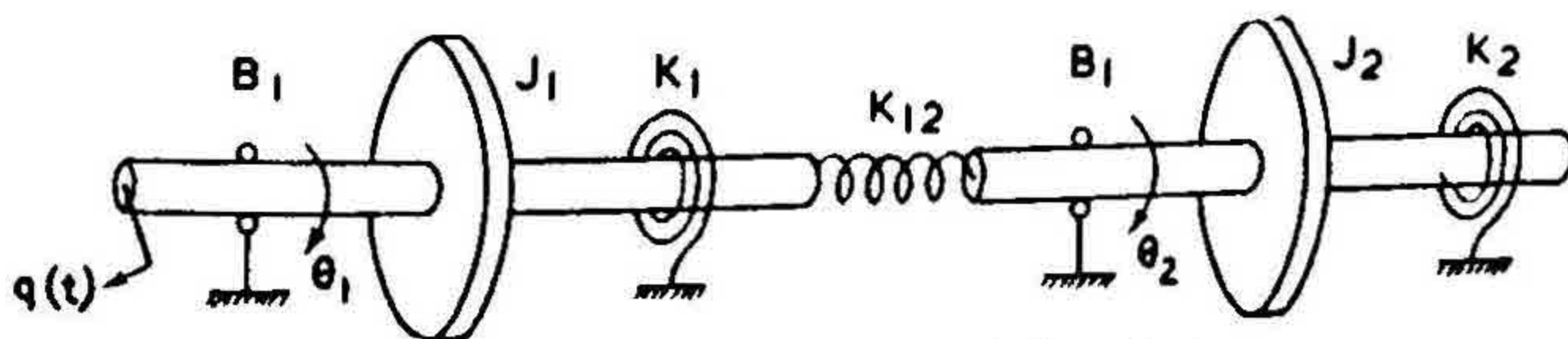

FIG. 8. A rotational-mechanical system.

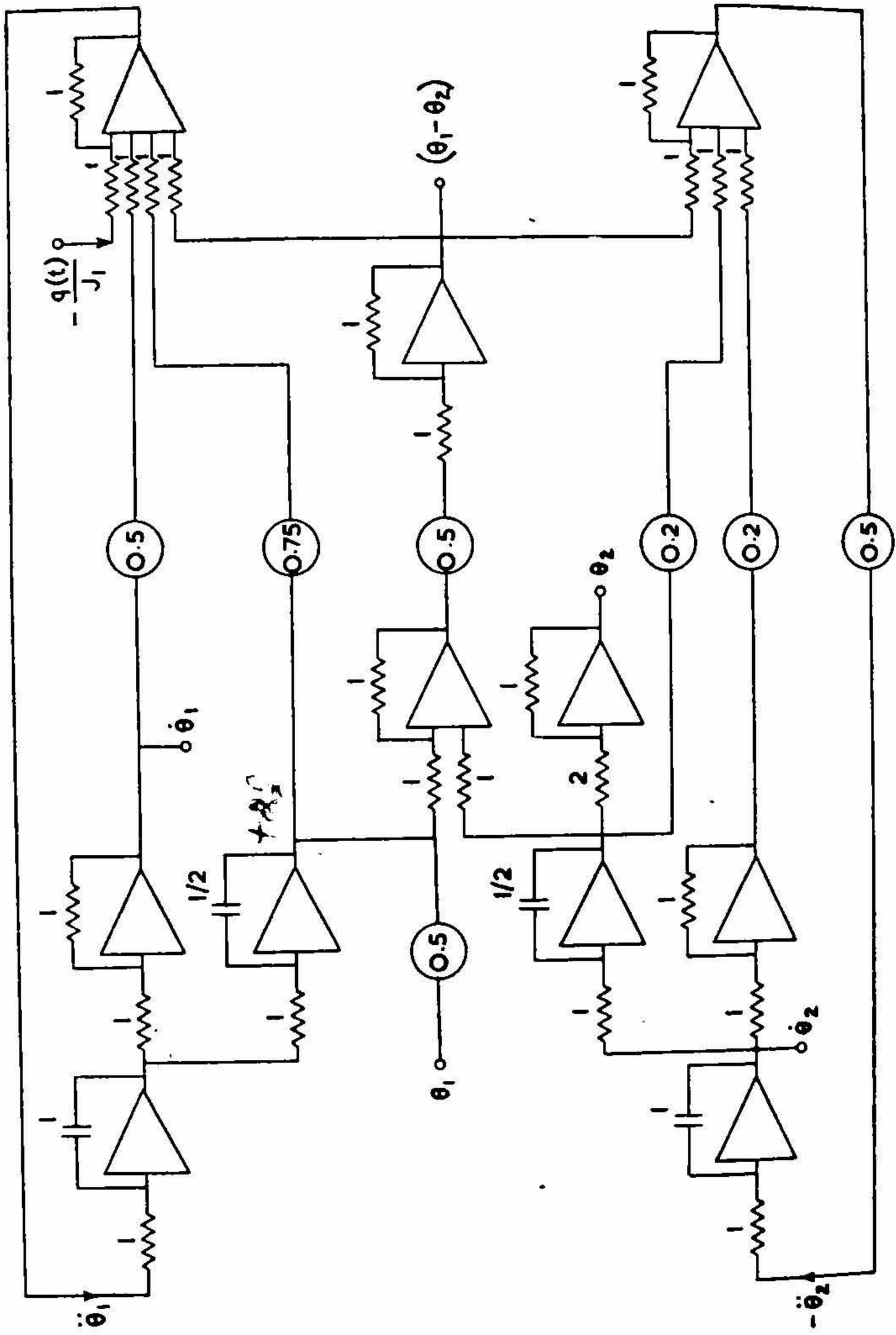

FIG. 9. Computer set-up for solution of the equations representing the system of Fig. 8.

(d) *Switching panel:* One panel is provided with two 5-position push-button switches to permit the oscilloscope to be rapidly switched from one computer output voltage to another.

(e) *Overload indicators:* The operational amplifiers overload at about +50 and -60 volts output. As shown in Fig. 5, small neon tubes which fire at 60 volts can be used directly to indicate overload in the negative direction, and, with a 10 volt negative bias, to indicate overload in the positive direction.

VII. SAMPLE PROBLEM SOLUTION

As an example of the solution of the equations for a linear system, consider a case which is similar to, but somewhat more involved than the case of Fig. 2 (a). Shown in Fig. 8 is a pair of inertia-spring-damper rotational-mechanical systems, coupled by a spring. The equations for the combined system are:—

$$q(t) = J_1 \ddot{\theta}_1 + B_1 \dot{\theta}_1 + K_1 \theta_1 + K_{12} (\theta_1 - \theta_2) \quad (5)$$

$$0 = J_2 \ddot{\theta}_2 + B_2 \dot{\theta}_2 + K_2 \theta_2 + K_{12} (\theta_2 - \theta_1) \quad (6)$$

These may be rewritten with the highest derivative on the left, to prepare for the computer set-up. Also, each equation has been divided throughout by J_1 , giving:

$$\ddot{\theta}_1 = \frac{q(t)}{J_1} - \frac{B_1}{J_1} \dot{\theta}_1 - \frac{K_1}{J_1} \theta_1 - \frac{K_{12}}{J_1} (\theta_1 - \theta_2) \quad (7)$$

$$\frac{J_2}{J_1} \ddot{\theta}_2 = -\frac{B_2}{J_1} \dot{\theta}_2 - \frac{K_2}{J_1} \theta_2 + \frac{K_{12}}{J_1} (\theta_1 - \theta_2) \quad (8)$$

Given $B_1/J_1 = 0.5$, $K_1/J_1 = 1.5$, $K_{12}/J_1 = 1$, $B_2/J_1 = 0.2$, $K_2/J_1 = 0.4$ and $J_2/J_1 = 2$, this problem may be set up as shown in Fig. 9. Note the similarity in the loops for each of the two similar parts of the system, and the provision for introducing the coupling term.

As a check on the set-up, the amplitudes of θ_1 and θ_2 in response to a sinusoidal input (q/J_1) of unit amplitude and unit frequency ($\omega = 1$ rad./csec, or $f = 199$ c.p.s.) were observed. The correct values may be very easily calculated in this case by substituting $(j\omega)^2 \theta_1 = -\theta_1$ for $\ddot{\theta}_1$, etc., and solving for the absolute values of θ_1 and θ_2 for $q(t)/J_1 = 1$. The results were:—

	Calculated values	Computer values
θ_1	0.32	0.30
θ_2	0.50	0.51

Because of the ease of calculation, sinusoidal checks of this sort are often very useful in computer studies of linear systems.

Assuming now that the responses of this system to a step input are desired, a square-wave of 20 csecs duration is applied to the q/J_1 input. The computer

solutions for the angular position and velocity response of each shaft as well as the angular position difference ($\theta_1 - \theta_2$) are shown in the oscilloscope photographs of Fig. 10.

It can be seen that the responses of this system to a step input are rather complex in form. Hand calculation of such responses, even with the aid of the methods of operational calculus and the use of tables, is very tedious. Furthermore, the work involved in hand computation will vary directly with the number of cases to be solved, if parameters must assume various values or if various driving functions are to be used.

The labour involved in setting up and checking the computer is not easy, but it is definitely a great time-saver even if only the few results shown are desired, providing of course that precision is adequate. Once the set-up is in proper operation, further solutions showing the results of parameter variation or of changes in driving function may be very quickly obtained.

A particularly valuable feature of the high-speed computer is that the change in response corresponding to a change in a parameter appears on the oscilloscope instantaneously, for all practical purposes. Adjustment problems, involving the choice of a parameter to yield some desired response, may, therefore, be handled with ease.

VIII. CONCLUSION

The computer described in this paper is still undergoing "shake-down" tests at the time of writing and many test problems such as the one described above are being used to check equipment and to give practice to persons interested. It can be confidently stated, however, that this device will prove to be a very useful teaching aid in such subjects as transients, servomechanisms, electrical machinery and acoustics, and that it will prove useful not only for academic research but also to those industries which have highly developed engineering groups.

IX. ACKNOWLEDGMENT

The assistance of Messrs. S. Sampth and N. S. Nagaraja in this work is gratefully acknowledged.

REFERENCES

1. Bush, V. .. "The Differential Analyzer. A New Machine for Solving Differential Equations," *Jour. Frank. Inst.*, 1931, 212, 447-88.
2. Lovell, C. A. .. "Continuous Electrical Computation," *Bell. Lab. Rec.*, March 1947, 25, 114-18.
3. Ragazzini, Randall and Russel .. "Analysis of Problems in Dynamics by Electronic Circuits," *Proc. I.R.E.*, May 1947, 35, 444-52.
4. "ENIAC" .. *Digital Computer Newsletter*, April 1949, 1, 1.
5. Rubinoff, Morris .. "Analogue versus Digital Computers—A Comparison," *Proc. I.R.E.*, October 1953, 41, 1254-62.
6. Strang, C. E. .. "Computing Machines in Aircraft Engineering," *Elec. Engg.*, January 1953, 72, 43-48.

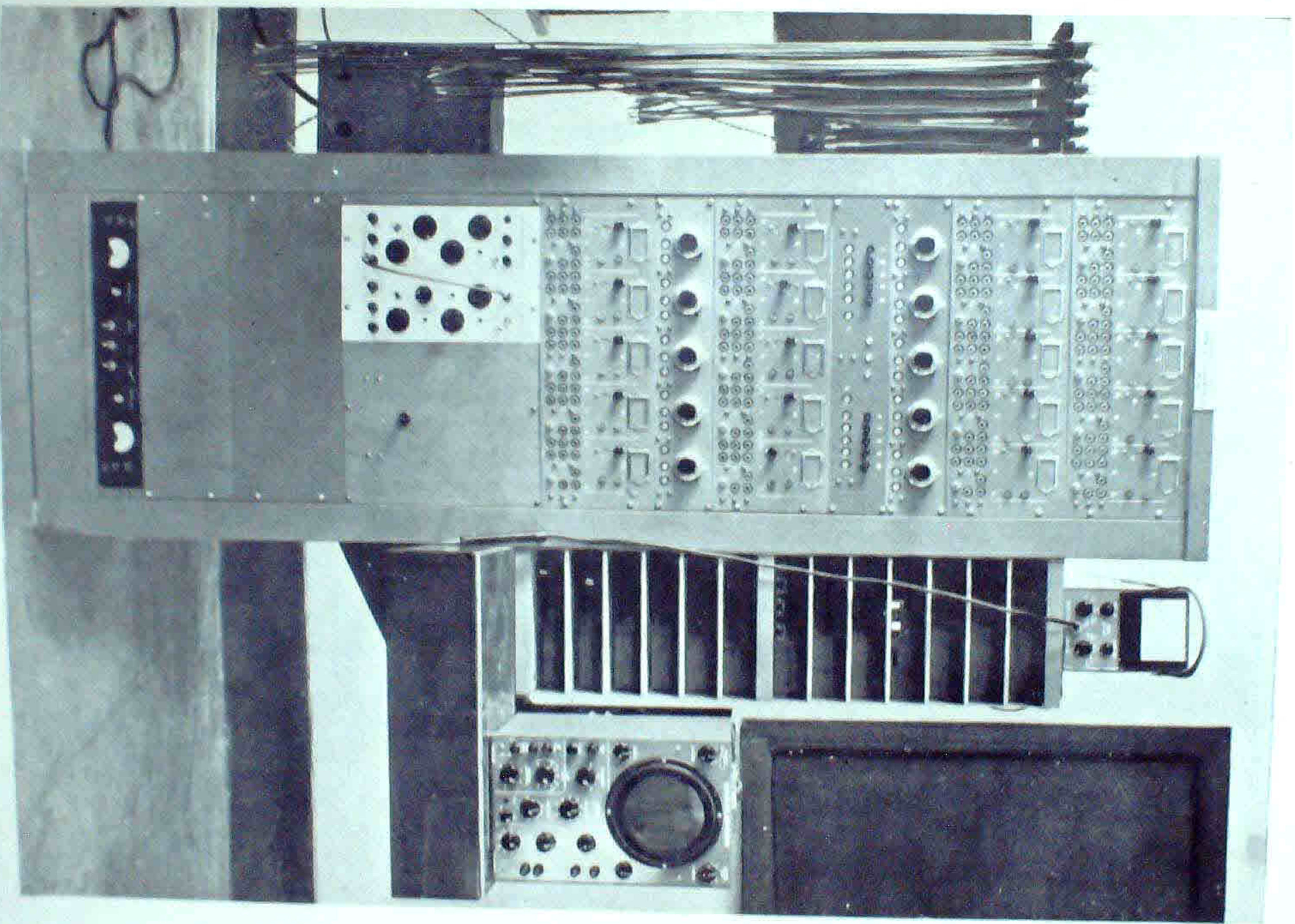

Fig. 4. Photograph of the computer before the addition of non-linear units.

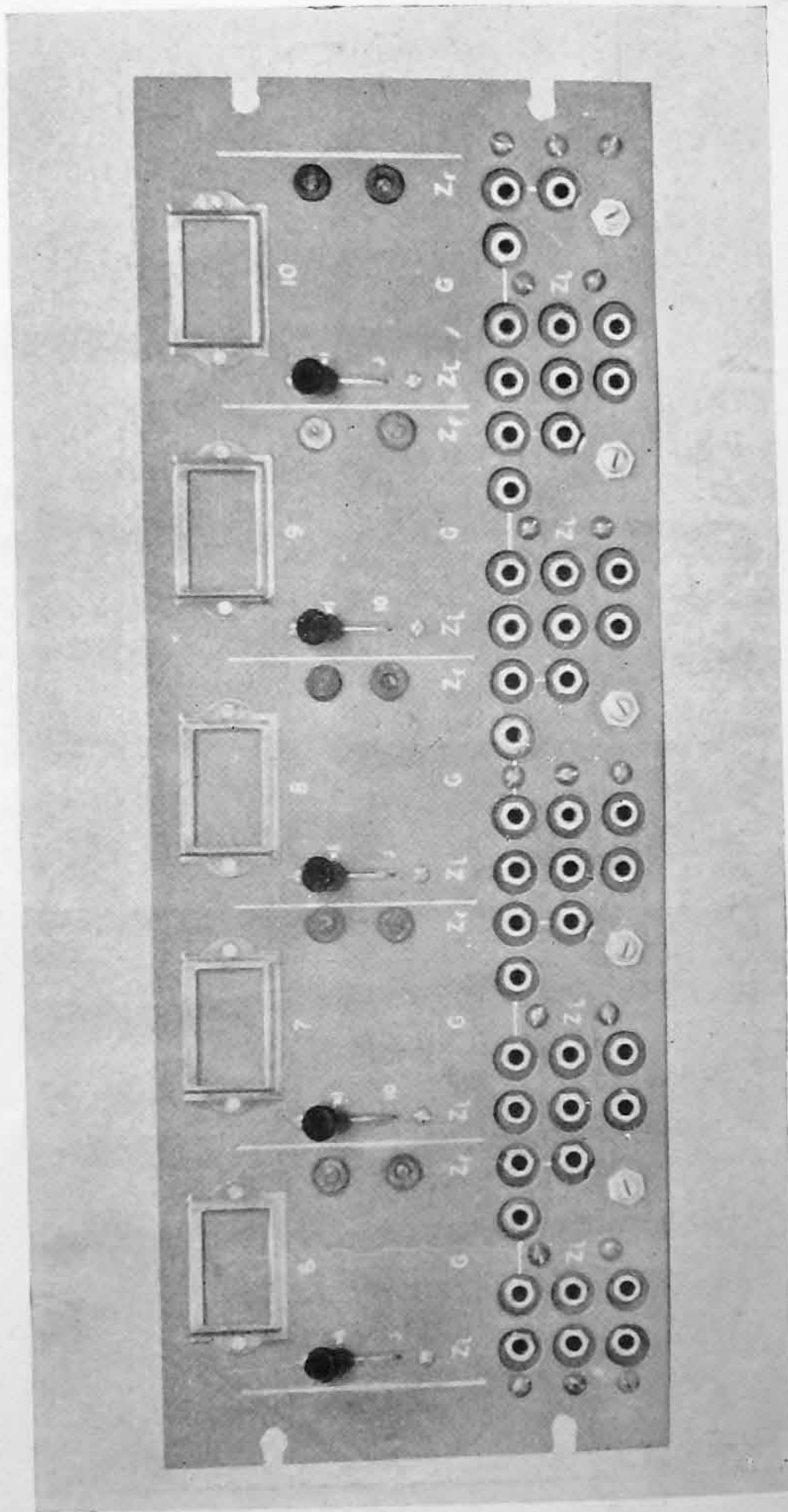

FIG. 6(a). Photograph of the front panel of a 5-unit operational amplifier chassis.

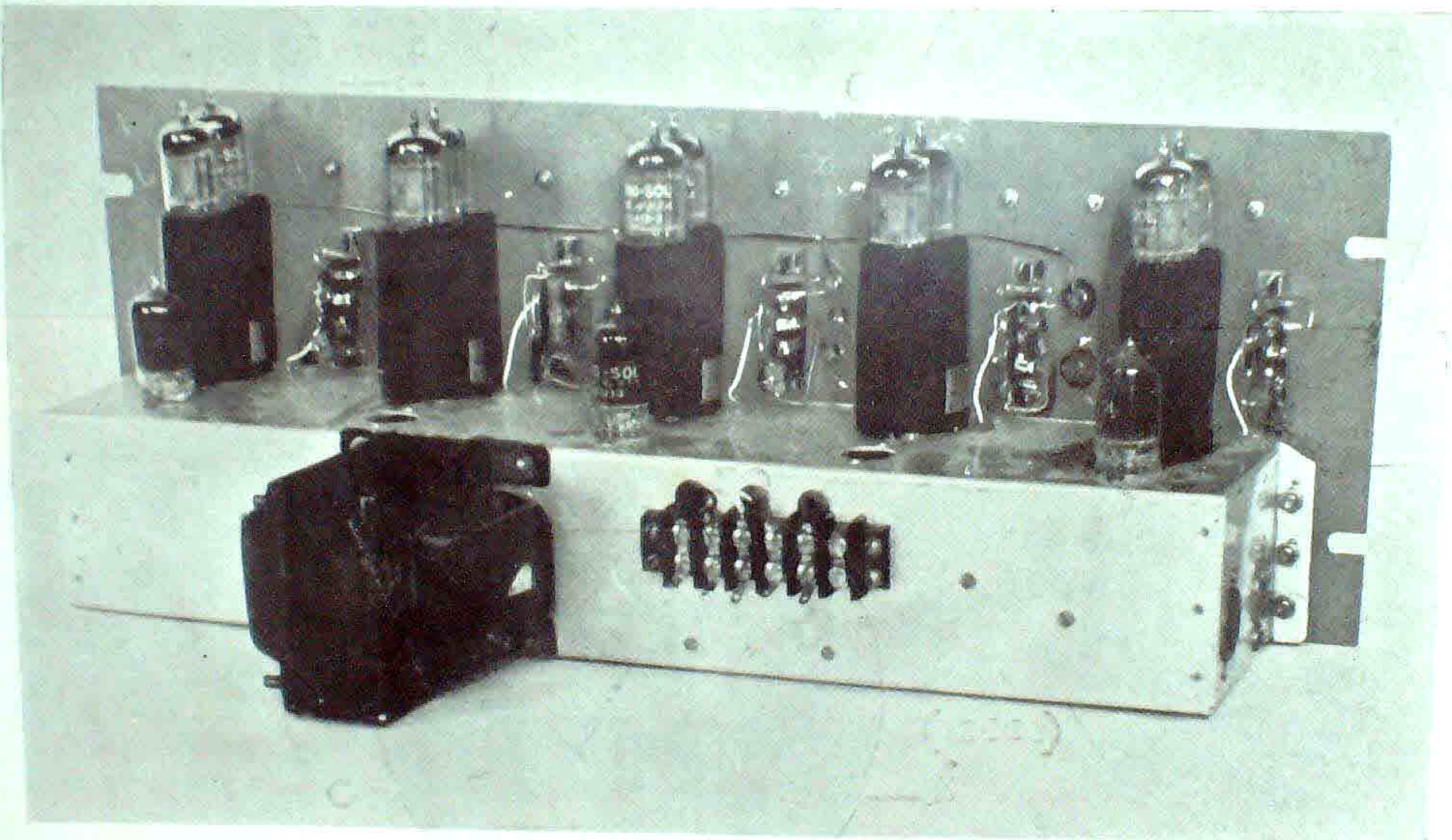
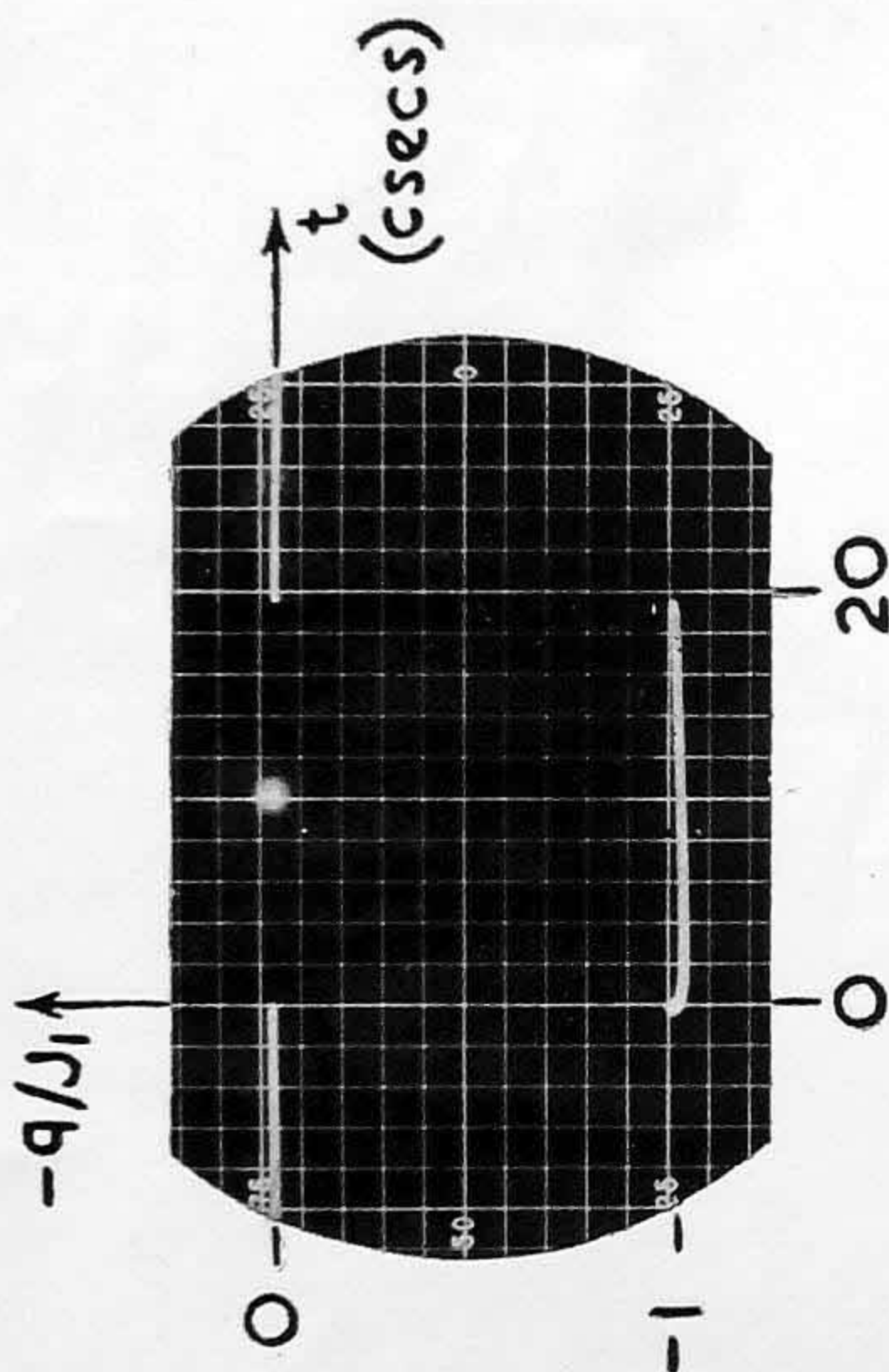
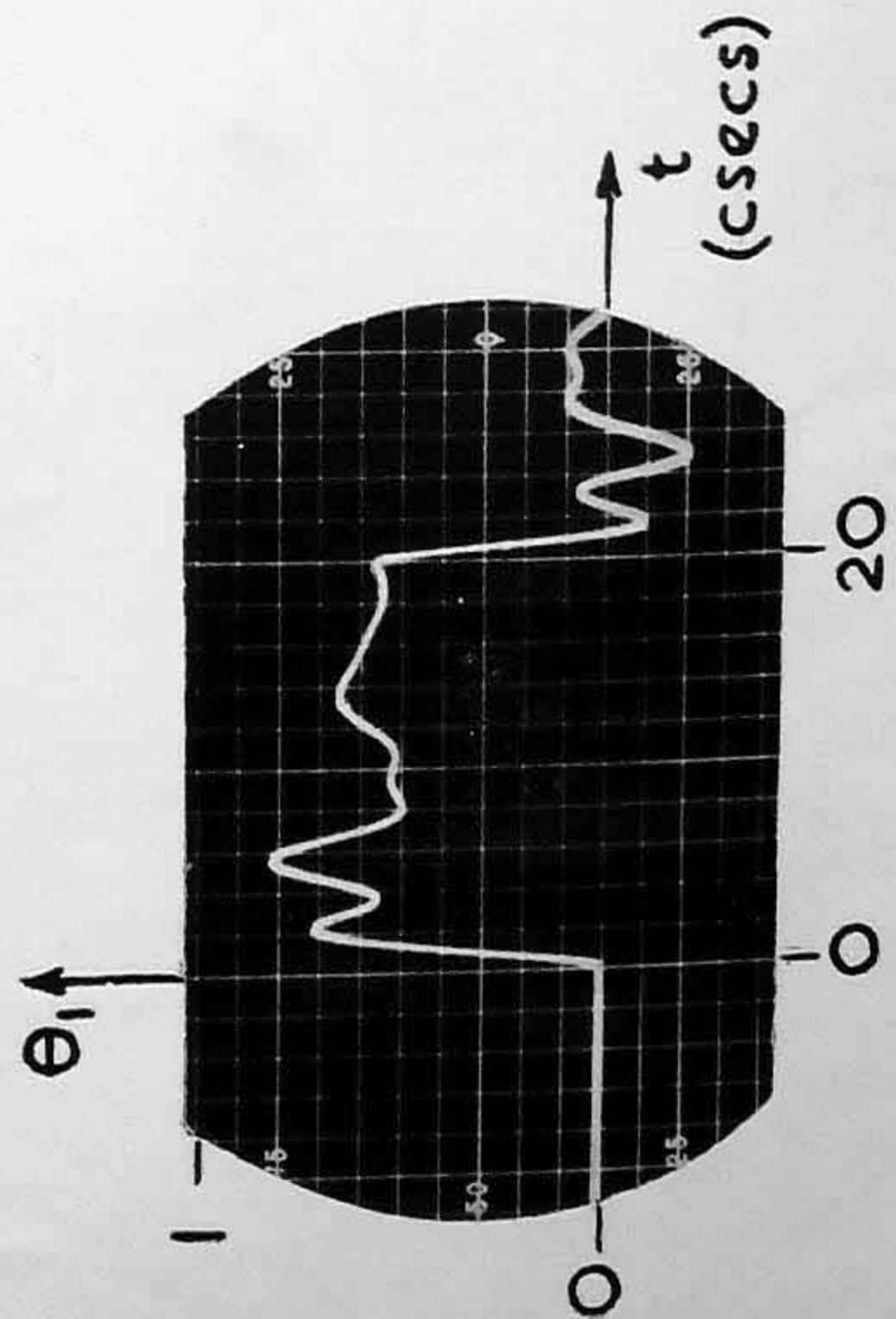

FIG. 6 (b). Photograph of the back of an operational amplifier chassis.



(a)



(b)

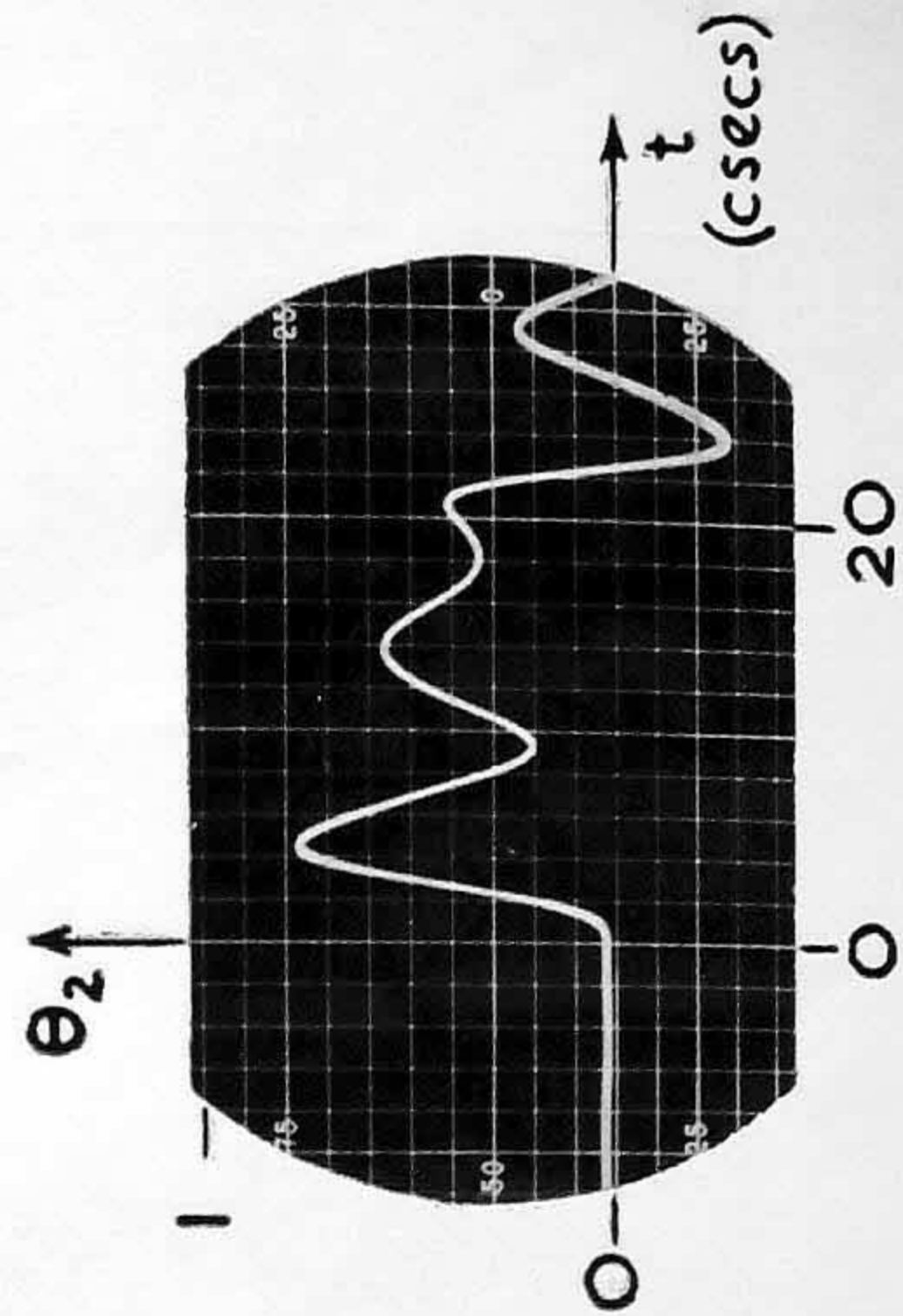

(c)

FIG. 10. Photographs of oscilloscope traces of computer solutions for the system of Fig. 8: (a) $q(t)/J_1$ the step-wave torque input, (b) θ_1 , angular position of the first shaft, (c) θ_2 , angular position of the second shaft.

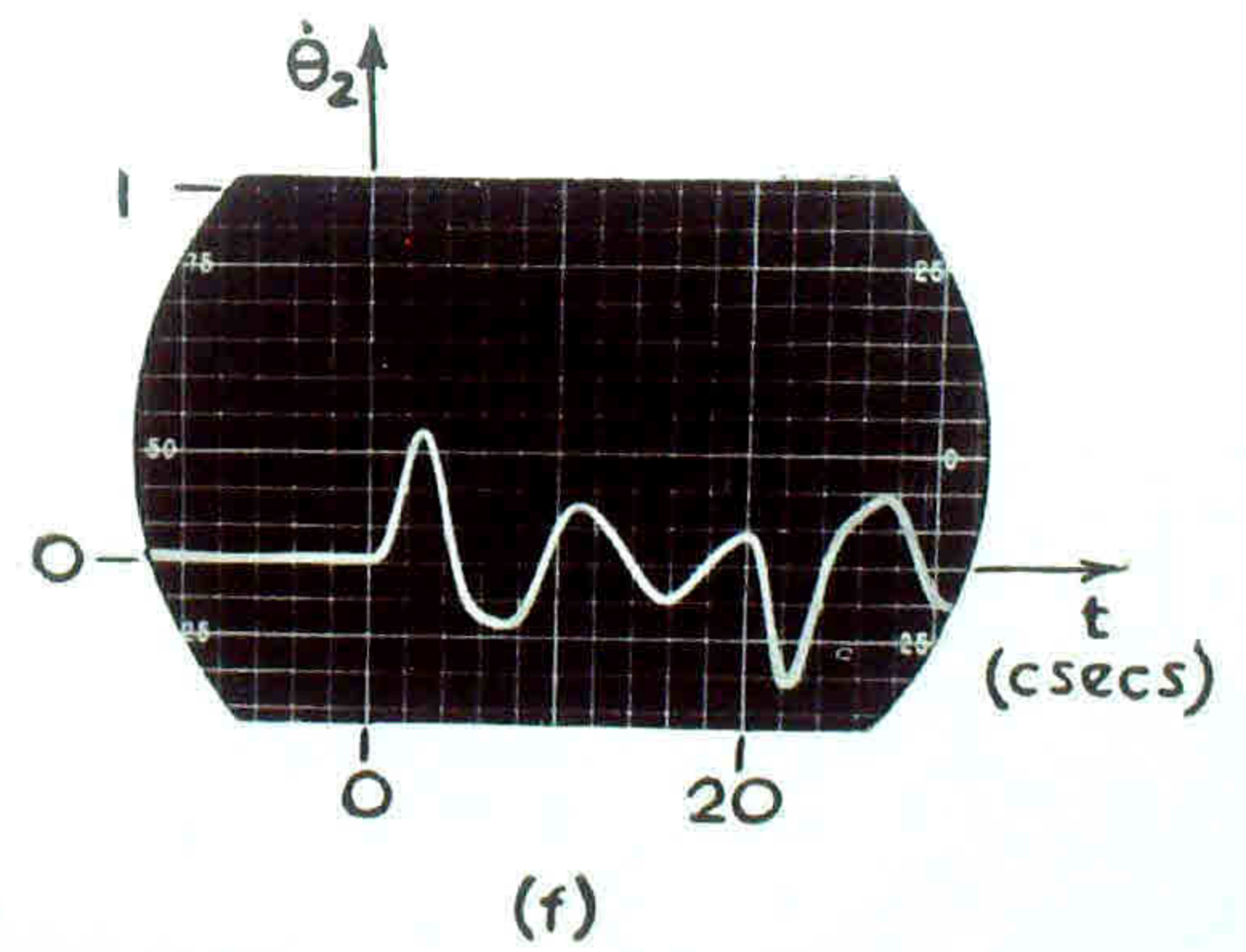
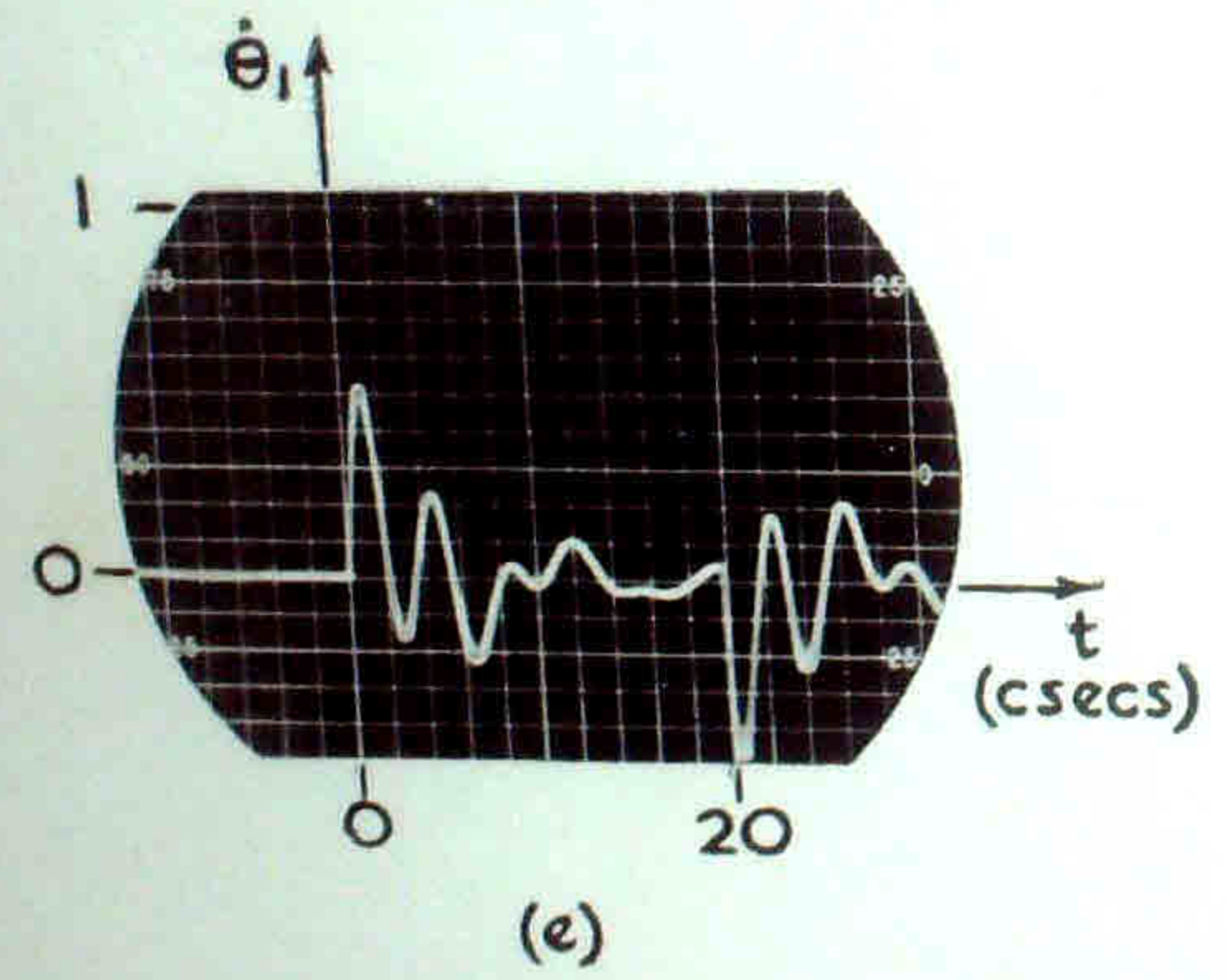
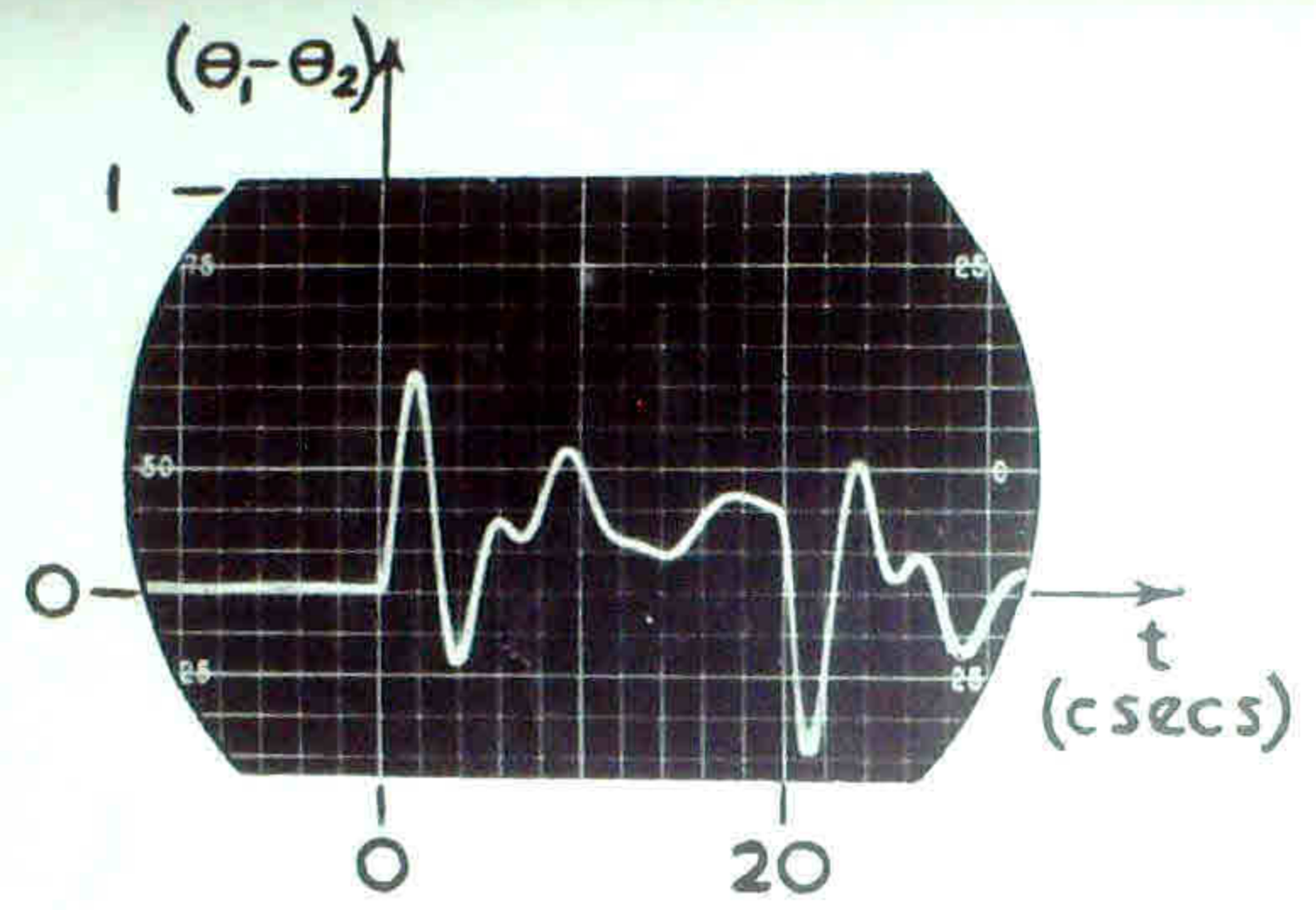

FIG. 10. Photographs of oscilloscope traces of computer solutions for the system of Fig. 8: (d) $(\theta_1 - \theta_2)$, difference of angular positions of the two shafts, (e) $\dot{\theta}_1$, angular velocity of the first shaft, (f) $\dot{\theta}_2$, angular velocity of the second shaft.

7. Soroka, W. W. .. "Analog Methods in Computation and Simulation," McGraw-Hill Book Co., New York, 1954.
8. Korn and Korn .. "Electronic Analog Computers," McGraw-Hill Book Co., New York, 1952.
9. Sprague, R. E. .. "Fundamental Concepts of the Digital Differential Analyzer Method of Computation," Computer Research Corp., Hawthorne, Calif.
10. Philbrick, George, A. and Paynter, Henry, M. "The Electronic Analog Computer as a Lab Tool," *Industrial Laboratories*, May 1952, 3.
11. MacNee, A. B. .. "An Electronic Differential Analyzer," *Proc. I.R.E.*, November 1949, 37, 1315-24.
12. "Catalog and Manual," G. A. Philbrick Researches, Inc., Boston, Mass.
13. MacNee, A. B. .. "Some Limitations on the Accuracy of Electronic Differential Analyzers," *Proc. I.R.E.*, March 1952, 40, 303-08.
14. Bell, H., Jr. and Rideout, V. C. "Precision in High-Speed Electronic Differential Analyzers," *Cyclone Symposium*, II, 1952, University of Wisconsin Engg. Exp. Station, Reprint No. 202.