

Switch mode rectifiers — A status review

MANJUSHA DAWANDE*, V. RAJAGOPALAN** AND G. K. DUBEY***

*Department of Electrical Engineering, University of Roorkee, Roorkee, Formerly with EE Dept. Univ. of Quebec

**CPPE-Hydro-Québec/NSERC, Industrial Research Chair, Département de génie électrique, Université du Québec à Trois-Rivières, Québec à Trois-Rivières, Québec, G9A 5H7, Canada

***Dept. of Electrical Engineering, IIT, Kanpur, 208016.

Abstract

This paper presents various single phase and three phase Switch Mode Rectifiers (SMRs). A comparative evaluation of SMR topologies is provided which helps the design engineer to select the low cost, best choice as per the application requirement. Several active current waveshaping techniques operating with continuous/discontinuous mode of conduction and variable/constant switching frequency operation have been discussed.

Key words: Switch Mode Rectifier(SMR), Active current waveshaping technique.

Discipline: Power Electronics Circuits - Devices, Topology, and Control.

1. Introduction

Since 1980, Switch Mode Rectifiers (SMRs), operating with close to unity power factor, have become the object of increasing interest. SMRs have been used extensively in power supplies, microprocessor development and computer supplies, industrial requirements like relay/digital hardwired/programmable logic controllers performing interlocking, sequencing and monitoring operations in refineries, coal mines, cement/paper/steel mills, telecommunication equipments, space equipments, military equipments etc. These applications require ac to dc uncontrolled converters to handle unidirectional power flow. The unidirectional power conversion has been done using primarily, single phase and three phase diode rectifiers. Today, in most cases single phase and three phase switch mode rectifiers have replaced them in low and medium power applications. Requirements and the limits specified by the IEEE standard 519 and IEC-555 aroused interest in active current waveshaping techniques and their use in SMRs¹⁻⁵. Active current waveshaping techniques are used for current harmonic reduction to satisfy IEEE standards. They overcome the disadvantages of passive current waveshaping techniques and improved the performance of the conventional single phase and three phase uncontrolled rectifiers significantly.

These SMRs are broadly classified as (1) single phase SMRs and (2) three phase SMRs. Variety of SMR circuit configurations have been developed in the past decade. These SMRs have employed different active current waveshaping techniques involving (i) Continuous Mode of Conduction (CMC) and (ii) Discontinuous Mode of Conduction (DMC). Continuous mode of conduction may have operation with (i) Constant Switching Frequency (CSF) or (ii) Variable

Switching Frequency (VSF) while discontinuous mode of conduction generally employs a constant switching frequency operation.

This paper gives a comparative evaluation of the available single phase and three phase SMR topologies and various active current waveshaping techniques used in SMRs.

2. Uncontrolled converters with passive techniques

Single phase and three phase diode rectifiers with output filters (L-C) are commonly used in many applications. These conventional rectifiers have the advantage of simple design, easy implementation and adequate reliability. However, they suffer from a number of disadvantages such as (i) pulsed input currents rich in harmonics (ii) distortion at the source terminals (iii) low power factor (iv) ripple in the output dc voltage etc. Further, the harmonics generated at the source terminals have a number of undesired effects such as malfunction of electronic equipments connected to the line, excitation of system resonances, overloading of capacitors, decrease in efficiency owing to increase in losses due to harmonic current, interference with telephone lines and saturation of transformers. The low power factor has to be compensated with appropriate reactive power compensation. Filters are required to remove input current harmonics. The output dc voltage ripple deteriorates load performance and there is a need for a suitable L-C filter to restrict the ripple content within reasonable limits⁶⁻¹².

Passive current waveshaping techniques were employed in the past¹²⁻¹⁴ to improve the power factor of the conventional single phase bridge rectifier. The techniques employed mainly passive filters such as (i) L-C filter (ii) resonant filter (iii) ferroresonant transformer at the input. An L-C input filter was commonly used with a single phase diode rectifier in the beginning^{12,13}. The power factor obviously improves with an increase in the value of L. However, the large value of L is uneconomical. The addition of capacitor C improves the power factor marginally (0.865) but does not improve efficiency and distorts the supply voltage significantly. The parallel and series resonant input filters have also been employed. The parallel resonant input filter can achieve a maximum power factor of 0.957¹³. The major disadvantages of the series resonant input filter are the large size of the passive elements and high rms current in the capacitor. The technique, hence, is found unsuitable for the normal supply frequency of 50/60 Hz. However, it is more suitable for high supply frequencies (20 kHz) in space platforms¹⁴.

In case of three phase bridge rectifiers with output L-C filter, a good power factor(0.95) can be obtained by maintaining the direct current constant through the inductor L. However, to satisfy these requirements, the value of inductor L required is considerably high. Also, harmonic analysis of the input supply current waveform shows the presence of high values of fifth and seventh harmonic components (20% and 14% of the fundamental respectively). These harmonics also cause distortion in the supply voltage.

Passive waveshaping techniques have been suggested to improve the input supply current distortion and power factor and to reduce input rms current for three phase converters. A three phase uncontrolled converter using a tuned L-C parallel tank circuit in the incoming supply lines has been suggested¹⁵. The tank circuit eliminates specific ac line current harmonics, thus improving input ac line current waveform, power factor and reducing the input supply voltage distortion marginally. As such, input filters are necessary to reduce the harmonics in the supply

lines. The filter size makes these rectifiers unattractive in some applications, although these are widely used in PWM based modern drives.

It should be noted that the output voltage control is not possible without appropriate change in the input supply voltage. The L-C filter at the output also does not provide good regulation of the output dc voltage. The passive current waveshaping techniques though simple, easy to implement and reliable, suffer from many disadvantages such as (i) requirement of large size of passive elements, (ii) improvement of power factor in narrow operating region and (iii) large output dc voltage ripple causing voltage control problems especially in inverter applications. These disadvantages are overcome by the active current waveshaping techniques. The active current waveshaping techniques make use of the self commutated switching devices such as MOSFETs, IGBTs etc. Active current waveshaping techniques show remarkable improvement in the performance. Variety of circuit topologies have been developed for single phase and three phase Switch Mode Rectifiers (SMRs). SMRs employing active current waveshaping techniques have definite advantages over passive current waveshaping techniques. The comparative study of active and passive waveshaping techniques is presented in reference¹⁶. Major advantages of SMRs using active current waveshaping techniques are mentioned below.

1. Very small lower order harmonic components in input current.
2. Small size of output dc voltage filter capacitor.
3. Close to unity power factor operation in wide operating region.
4. High efficiency.
5. Light weight and reduced size and hence could be portable.
6. Economical.

However, active current waveshaping technique has the disadvantage of requiring additional control logic.

3. Single phase SMR

A boost type ac-dc converter is shown as in fig.1. Fig.1 (a) and (b) are well suited for single phase and three phase SMR respectively. Several authors have used this topology extensively¹⁷⁻²⁸ using various approaches. In this converter, switching occurs at a rate substantially higher

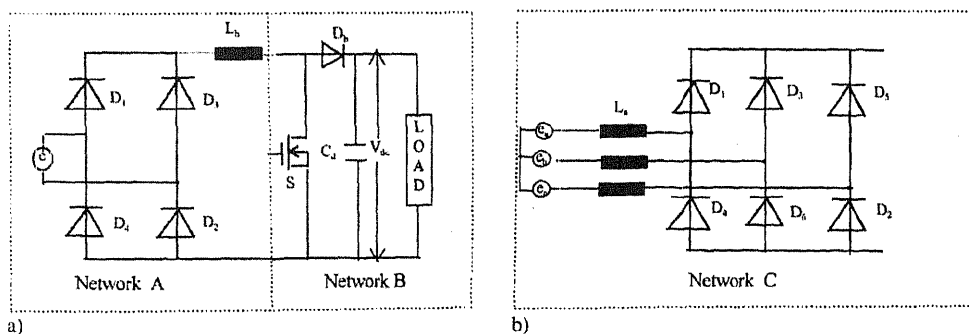

Fig. 1a. Boost type SMR, b) Network C for three phase SMR.

than the line frequency. In a switching cycle, during the ON interval of the switch the inductor connected in line charges up to a current value, which is proportional to the supply voltage and during the OFF interval of the switch it discharges in the load.

The standard single phase SMR is shown in fig.1(a). It is an elementary boost rectifier which consists of a single phase diode bridge, a boost switch S (such as MOSFET), a boost inductor L_b , a blocking diode D_b , and output capacitor C_d ¹⁷⁻¹⁹. This configuration provides the following advantages :

1. Full bridge diode rectifier allows optimum utilization of input voltage and power delivered.
2. The rectifier input voltage has a three-level waveform as seen from the supply side which helps in reducing the input current harmonics. The harmonics can be easily filtered using a small value of capacitor connected across the supply terminals.
3. Single capacitor bank is required.

However, this standard SMR has the following disadvantages.

1. The dc side inductor has to work satisfactorily without saturation. This may constrain the use of an iron core inductor under certain conditions depending upon the ripple current and the switching frequency.
2. A separate blocking diode D_b on the output side is required to avoid discharging of output capacitor C_d during ON mode of the switch.
3. The ON mode losses depend upon the conduction of two diodes of the bridge rectifier and the switch while OFF mode losses depend upon conduction of two diodes of the bridge and the blocking diode D_b . Therefore, conduction losses are considerable.

Various other single phase SMR configurations have been developed. They are shown in fig.2 and fig. 3. These SMRs overcome one or more disadvantages of the standard SMR. Brief description of these SMRs and their comparative study are given below.

SMRs shown in fig.2 (a,b,c,e)²⁰⁻²³ show the notable changes such as dc side inductor is no longer necessary; instead an ac side inductor is required. It helps also in reducing the Electro Magnetic Interference (EMI) effect. The blocking diode D_b is also eliminated. The use of intrinsic diodes of the MOSFETs is done effectively in (a-c) and (e). SMRs shown in fig.2 (a-b) give the additional advantage that lower conduction losses are possible, because the current flows through two semiconductors (one diode, one MOSFET) only in both the modes of operation. Configuration of fig.2 (c)²⁴ with two switches connected at input side has been extrapolated for three phase SMR. SMR with centre-tapped transformer²² is of fig.2 (d) also has low conduction losses. SMR of fig 2 (e) uses only two diodes but requires two output capacitor banks. The banks produce higher ripple voltage compared to a single capacitor bank. The required value of capacitor goes up for the same output power, output dc voltage and ripple voltage. However, this configuration has an added advantage of direct extension to three phase, where a modest value of the output capacitor bank will be required. Multichannel Switch Mode Rectifier (MSMR)^{22,25,26} is shown in fig. 2 (f). It has two channels and each channel can operate independently. Two channels help in reducing the input current ripple. Further ripple reduction of the current is possible by additional channels.

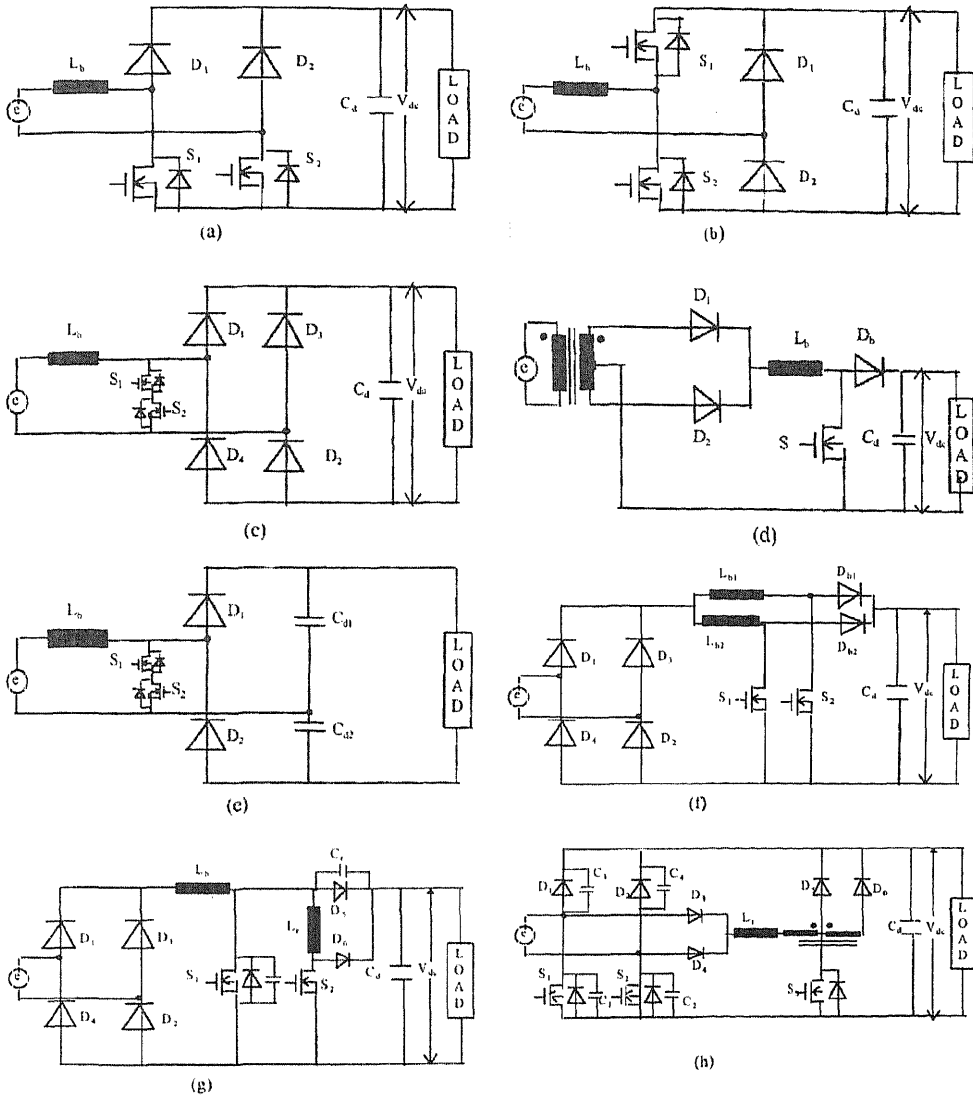

FIG. 2. Single phase SMR configurations.

How to increase the efficiency of the SMR further has become a topic of interest. Going back to the discussions on conduction and commutation losses, it is true that the standard SMR has commutation losses which reduce the overall efficiency of the SMR. Similarly the switch used in standard SMR undergoes hard commutation. The conduction losses are significant, as the current flows through three power semiconductors simultaneously. SMR in fig.2 (g) reduces the commutation losses of standard SMR by using auxiliary commutation circuits^{27,28}. However, the conduction losses continue to be high. Both conduction losses (due to only two devices in current path) and switching losses (due to soft commutation) are reduced in SMR of

fig.2 (h)²⁹. Zero Voltage Switching (ZVS) commutation is composed of auxiliary diodes D_3, D_4, D_5, D_6 , the resonant inductor L_r , the resonant capacitors C_3, C_4 , an auto-transformer and auxiliary switch S_3 . The intrinsic diodes and capacitors of the MOSFETs S_1 and S_2 also involve in the soft commutation process. The basic idea used for reduction of the conduction losses in the device is that the MOSFET that is ON will conduct the current in the reverse direction (from source to load) and the current will not flow through the intrinsic diode of the MOSFET but through the MOSFET itself. Secondly, the voltage stresses for all power semiconductor are fixed under all load conditions. Therefore, a higher efficiency is achieved by ZVS commutation of the main switches and ZCS commutation of the auxiliary switch.

The simple SMR with minimum number of components, low conduction losses, high input power factor and higher efficiency, fig.2 (a), has been adopted easily by the industries. Hybrid power module²³ developed by International Rectifier (IR) of this SMR is shown in fig. 3. Table 1 gives a comparative list of the available SMRs in terms of number of diodes, MOSFETs, inductors and capacitor banks required. It gives the Forward Blocking Voltage (FBV) capability³⁰ required for the switching device in the respective SMR.

4. Active waveshaping techniques

Active current waveshaping techniques are broadly classified in two modes of conduction.

1. Continuous Mode of Conduction (CMC)
2. Discontinuous Mode of Conduction (DMC)

Continuous mode of conduction adopts two ways of operation namely, (i) Constant Switching Frequency (CSF) and (ii) Variable Switching Frequency (VSF), while the discontinuous mode of conduction operates mostly with constant switching frequency operation.

A. Continuous mode of conduction

The various active current waveshaping techniques have been implemented with standard SMR. The major control strategies used are mentioned below.

1. Hysteresis Current Control (HCC) with constant hysteresis current window^{20,30-32}
2. Bang bang Hysteresis Current Control¹⁷⁻¹⁹
3. Constant Switching Frequency current control with error traingulation³³
4. Constant Switching Frequency with predicted current control³⁴
5. Sinusoidal Pulse Width Modulation (SPWM) control²¹
6. Indirect Current Control (ICC)^{35,36}

Control techniques 1 and 2 operate with variable switching frequency, while the other strategies operate at constant switching frequency.

Variable switching frequency techniques

In case of SMR using HCC with constant hysteresis window^{20,30-32}, the input current drawn from the source is maintained within a current window $\pm \Delta i$. The actual current, therefore, follows the reference current closely within the window $\pm \Delta i$. Obviously for small values of $\pm \Delta i$

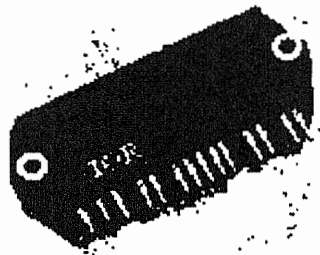
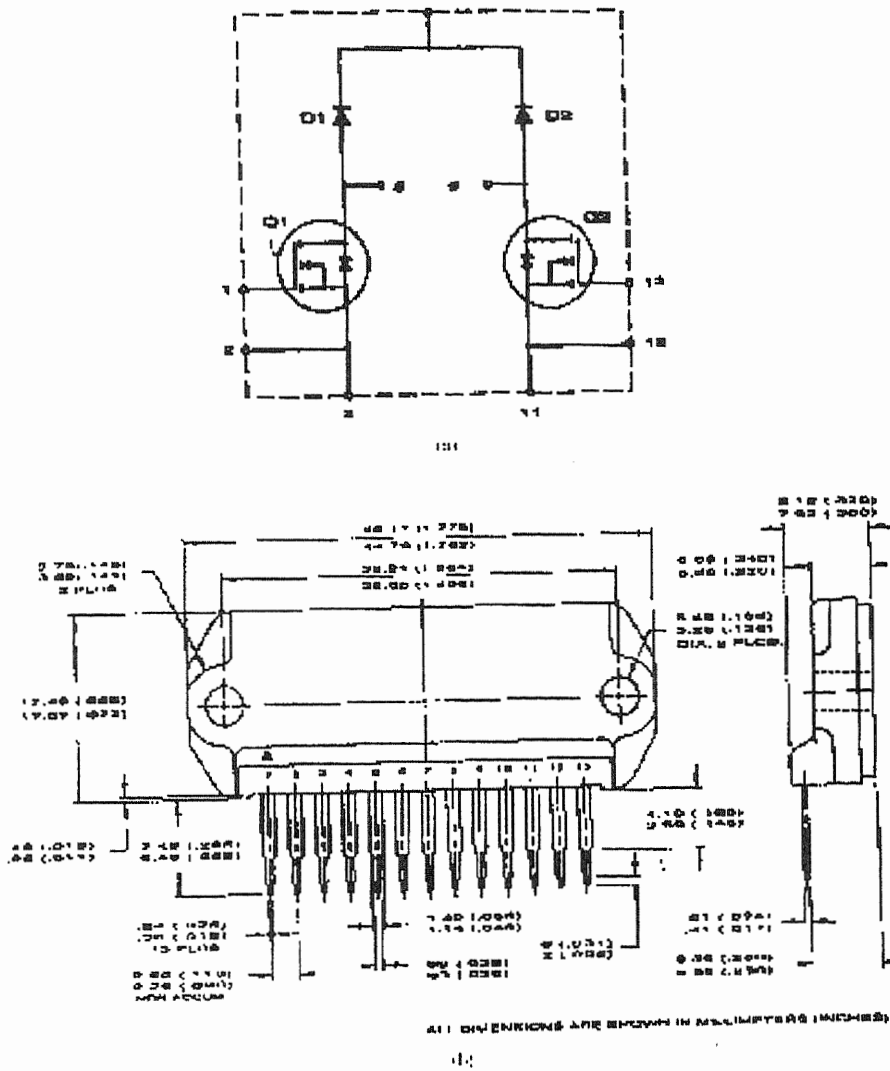

FIG. 3. Hybrid power module of SMR (courtesy International Rectifier).

Table 1.
Single Phase SMRs

Configurations	Diodes		MOSFETs			Inductors		Capacitor banks
	Separate diodes	Intrinsic diodes	AC side	Bridge arm	DC side	AC side	DC side	
Fig.1 and 2								
Fig.1(a)	5				1		1	1
Fig. 2(a)	2	2		2		1		1
(b)	2	2		2		1		1
(c)	4	2	2			1		1
(d)	3				1		1	1
(e)	2	2	2			1		2
(f)	6				2		2	1
(g)	6	1			2		2	3
(h)	6	3		2	1		1	5

the input current drawn is near sinusoidal. The switching frequency is a function of $\pm \Delta i$ and increases considerably for small values of $\pm \Delta i$. SMR with this control strategy is fairly simple.

In case of bang bang hysteresis current control¹⁷⁻¹⁹, the instantaneous value of $\pm \Delta i$ depends upon the instantaneous value of current reference and is a fixed percentage of it. This control strategy yields instantaneous current control which is its main advantage. However, it has the serious disadvantage that the switching frequency is very sensitive to the load conditions. Specifically, the switching frequency is very high near the zero crossover of the current. A digital controller (P and PI) for bang bang current control is realized with standard SMR.

HCC techniques are simple to implement and yield fast dynamic response, however suffer from the disadvantages of non-uniform gating instances, and variable and load dependent switching frequency. The disadvantages of variable switching frequency operation in SMR have been eliminated by constant switching frequency operations which are discussed below.

Constant switching frequency techniques

In case of constant switching frequency current control with error triangulation³¹, the error between the reference and feedback currents is triangulated to get the necessary gating pulses for the control of the boost switch and the error is forced to remain between the maximum and minimum levels of the triangular waveform. In this manner, input current follows the reference current waveform closely. The technique, however, has a restricted current control range, which is a disadvantage.

Constant switching frequency with predicted current control³⁴ operates with the average OFF duty ratio 'd' which is formulated by combining the ON and OFF modes of operation. The quantity d is compared with a triangular waveform of desired switching frequency to obtain the gating signals for the switching device. The value of d varies between 0 and 1 and its instantaneous value is predicted for the next switching cycle. However, the complexity of the control circuitry increases and simplicity is lost.

Conventional SPWM technique^{21,29} is implemented in SMR. It does not require any elaboration here. It is applied at higher carrier frequencies so that the dominant harmonic component

can be easily filtered out with small values of filter components. SPWM being a constant switching frequency operation overcomes the disadvantages of HCC.

The Indirect Current Control is obtained by proportional dc voltage feedback and considering the $L \frac{di}{dt}$ effect in the feedback loop for dynamic compensation^{35,36}. It indirectly controls the phase and magnitude of the supply current. SMR with ICC may use two series connected converters for implementation²². One of the converter is a unidirectional power converter and the other a bi-directional auxiliary converter. SPWM technique is used for the control of both the converters. It eliminates the need of current sensing. However, the requirement of two SMRs is uneconomical.

B. *Discontinuous mode of conduction*

Discontinuous mode of conduction mostly operates with constant switching frequency. It is robust and its implementation cost is low, because it does not require sensing of input voltage. During the ON mode of operation of the boost switch, the input ac current flows through a boost inductor, diodes and switch. Consequently, the input current begins to increase at a rate proportional to the instantaneous value of supply voltage. Since the supply voltage varies sinusoidally, the peaks of input current also vary sinusoidally. The rectifier input current drawn from the supply is in the form of discontinuous pulses. The input current consists of fundamental component of utility mains frequency and a band of unwanted high frequency components centered around the switching frequency of the boost switch. Since the switching frequency is in the order of several kHz, filtering out of the unwanted input harmonics becomes easy with less bulky filter.

It can be noted that the input current control in discontinuous mode of conduction, DMC, can be achieved by following modes of operation of the boost switch:

1. Constant ON time control
2. Constant OFF time control
3. Constant frequency with turn-on at clock time control
4. Constant frequency with turn-off at clock time control

The DMC is discussed in detail with three phase SMRs in the next section.

5. **Three phase SMR**

The three phase SMR can be constructed by replacing the network A of fig.1(a) by network C of fig.1(b). The remaining dc converter network remains unchanged.

A three phase SMR with HCC technique has been realized using three single phase SMRs³⁷. The circuit configuration is shown in fig. 4. It operates with continuous mode of conduction and retains all the advantages of HCC technique mentioned earlier. This configuration, however increases the number of components to three times as compared to a single phase SMR and also generates triplen harmonics in the input supply current. Full utilization of the transformer core and copper for the windings is not possible owing to the use of three individual single phase transformers.

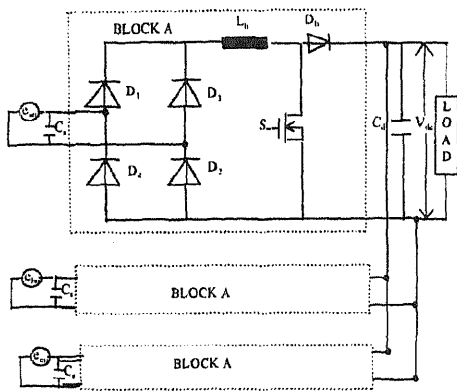

FIG. 4. Three phase SMR using three single phase SMRs.

The three phase SMR operating with DMC³⁸ is shown in fig.5 (a). It uses a single boost switch on dc side to control the load power flow. Each diode in the rectifier conducts for 180 degrees. The ON time of the boost switch and its switching frequency is controlled to give discontinuous current pulses. The peaks of the current pulses show a sinusoidal envelope. Due to the high switching frequency of the boost switch, the lower order harmonics are considerably reduced. The number of components in this SMR are quite less as compared to the three phase SMR using HCC technique as mentioned earlier. This three phase SMR overcomes all the disadvantages of the three phase SMR suggested in fig. 4 while retaining all the advantages. However, it has the following disadvantages.

1. Substantial increase in current stresses of the switching device and diodes due to the discontinuous nature of the current.
2. High ripple content of the switching frequency in the rectifier input currents.
3. Poor power factor at low duty cycle operation of boost switch.
4. No linear relation between reference and actual current. This poses difficulties in obtaining a closed loop control scheme.

Last two disadvantages have been eliminated by developing a technique which operates with DMC and uses Equal Area Criterion (EAC)³⁹. Two techniques are suggested for the discontinuous conduction viz. (1) Variable turn-on time (2) constant turn-on time. Three phase SMR shown in fig.5(a) uses constant turn on time operation. EAC means that it should yield the same area for the discontinuous current pulse as that of the area under reference input current in every switching period. Two programmable methods have been suggested to derive the turn-on time mathematically. This criterion gives the linear relation between reference and actual currents which helps to realize a simple closed loop control system. High power applications are possible, because of good performance achieved even at low switching frequencies, which are within the capabilities of GTO's and IGBTs.

Three phase SMR with DMC, fig.5 (a), has been analyzed by space vector calculus which allows a direct mathematical description of three phase systems. This avoids the use of a single

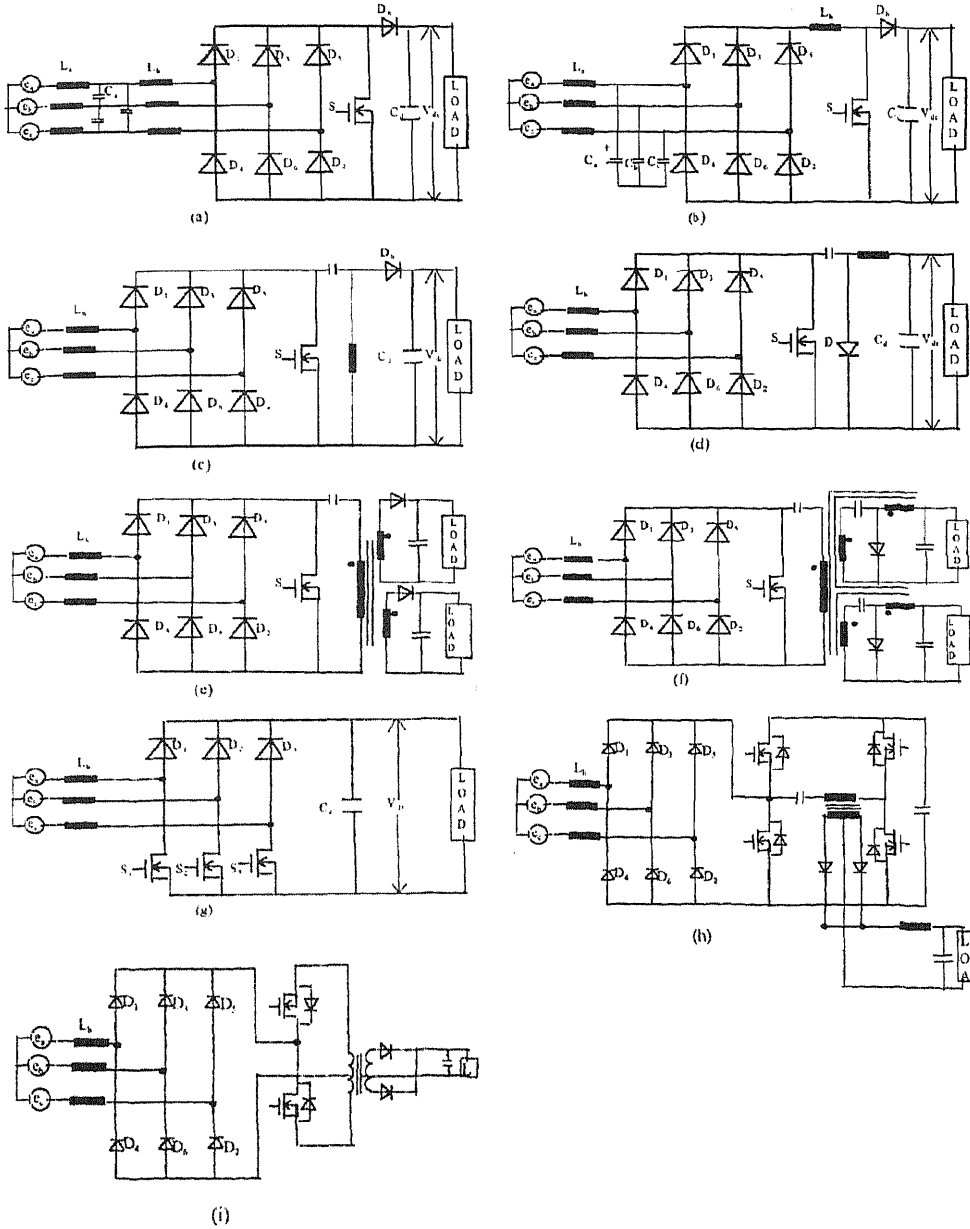

FIG. 5. Three phase SMR configurations with DMC.

phase equivalent circuit. Space vector based analytical analysis shows the effect on the mains of three phase SMR by the dynamics of the output voltage control. This analysis is based on substitution of discontinuous time shapes within a pulse period by quasi-continuous time shapes.

This quasi-continuous space is decided by the average pulse period. The detailed study of the input current shape dependency and voltage transformation ratio is carried out⁴⁰. Method has been evolved to determine the component stresses in a three phase SMR with DMC^{41,42}. Peak, mean and rms values of component currents of three phase SMR with DMC are calculated analytically. This helps in dimensioning of the devices of the input circuit and analyze the behaviour of SMR with DMC.

SMR shown in fig.5 (b) uses the input capacitors Ca, Cb, Cc connected to each phase and the boost inductor is connected to the dc side of SMR⁴³. It operates with DMC. The energy transfer from input capacitor to boost inductor takes place during the ON mode of boost switch. Therefore, the capacitors are discharged by the resonating switch current. Diodes of the bridge start conducting after the discharging of the input capacitors. The energy stored in the boost inductor is delivered to the load during the OFF mode of operation. Input capacitors are charged again with respective phase currents till the ON mode operation. This SMR configuration gives the additional advantage of diode conduction with zero volt/current switching.

The family of SMR topologies operating with DMC have been reported. Three phase SMR with a single switch and inductive input with one inductor and one capacitor or two inductors and two capacitors⁴⁴ produced the variety in three phase SMR topologies. They are shown in fig. 5(c–d). Three phase single switch SMR with isolated multiple output topologies are shown in fig. 5(e–f). Three phase multiple (three-switch) switch SMR is shown in fig. 5(g). The control scheme is simple, though three switches are used, because all the three switches are gated by the same control signal. It reduces further the current stresses on an individual switch. Fig. 5(h) uses the capacitor for internal energy storage. It provides the additional facility of output voltage hold up in the event of ac line voltage failure. Another three phase SMR which uses cascaded push-pull arrangement is shown in fig. 5(i).

SMR with continuous mode of conduction is presented and shown in fig. 6(a). The drawbacks of DMC are eliminated here. Moreover, the drawbacks of SMR of fig. 4, operating with CMC are also overcome by using a single three phase bridge rectifier and not three single phase SMRs. This SMR requires six switching devices on the ac side and allows 180° conduction of the rectifier diodes. HCC is employed for realization of the SMR²⁴.

Few more SMR configurations operating with CMC have been reported. Fig.6 (b-d) use the PWM and HCC waveshaping techniques. These SMRs require six switching devices. The star connected and delta connected bi-directional switches have been shown in SMR in Fig. 6(c) and (d) respectively. Two current control operating modes for the SMR are suggested. These modes are based upon a stacked dual boost converter. A dual current control mode obtains very low current THD⁴⁵.

The techniques discussed above are mostly based on current waveshaping techniques, thus, preventing current harmonic components to be generated. Another approach of dc line current modulation is suggested for line current rectification. It has been shown in the literature that the line current harmonics can be significantly reduced by modulating the dc side current at harmonic frequency and then injecting the modulation current back in to the ac side⁴⁶. To achieve

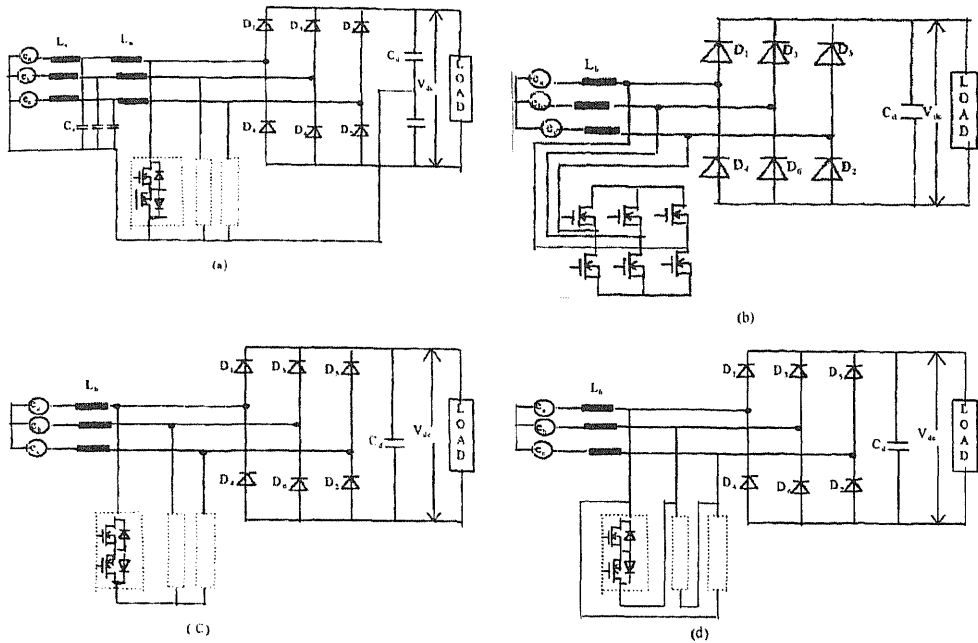

FIG. 6. Three phase SMR configurations with CMC.

nearly sinusoidal line current rectification in three phase SMR, the harmonic injection scheme has been implemented⁴⁷. Fig. 7(a) shows the three phase SMR with third harmonic modulated interface with three phase supply. The reduction of the line current harmonics is obtained by injecting the third harmonic current. The scheme consists of two step up dc-dc boost converters which modulates the current in the dc link and makes it $(i_d + i_3)$ and $(i_d - i_3)$, where i_3 is the third harmonic modulation current flowing in the dc-link inductors. The summed up current $2i_3$ is injected into the ac side of the rectifier by means of a current injection network which comprises three L_i, C_i branches. The injected current subtracts from the rectifier input current and makes the supply current more sinusoidal. However, this is achieved by the addition of one switch and additional control complexity.

Further, the problem due to high frequency operation requires to minimize the EMI and switching losses. This minimization is made possible by incorporating the Zero Voltage Switching (ZVS) or Zero Current Switching (ZCS) techniques. Advantages of ZVS and ZCS techniques include reduction of switching losses in the semiconductor switches and operation at high frequencies, thereby reducing the size of magnetic storage and filter components. A zero current switching in three phase rectification circuit is obtained at an additional cost of Zigzag transformer⁴⁸⁻⁵⁰. SMR in Fig. 7(b) implements the Zero Current Switched Quasi Resonant (ZCS-QR) boost converter instead of using a hard switched boost converter as in Fig. 7(a). It is referred to as “Three Phase Minnesota Rectifier”. The third harmonic injection is done through zig-zag transformer. However the principle remains the same as discussed earlier⁴⁷. Table 2 gives a comparative study of the sixteen three phase SMRs in terms of number of diodes,

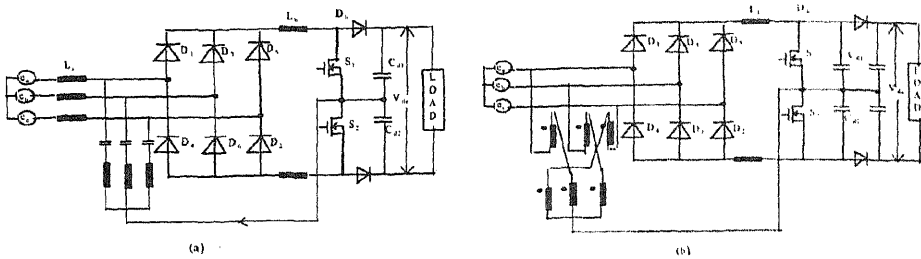

FIG. 7. Three phase SMR configurations with harmonic injections.

MOSFETs, inductors and capacitor banks etc. It also helps in finding the Forward Blocking Voltage(FBV) capability required for the switching device in respective SMR.

6. Conclusions

Single phase and three phase switch mode rectifiers have been used extensively in many applications. Nine single phase SMR configurations and sixteen three phase SMR configurations have been reported here. It gives the ready reference of all possible SMR topologies, required number of semiconductor switches, filter components which help in finding the losses in the devices, device ratings, efficiency, weight, cost etc. Active current waveshaping techniques operating with CMC and DMC are discussed here. Techniques such as HCC operate with variable switching frequency while SPWM, EAC, ICC operate with constant switching frequency. SMR using ZCS/ZVS, space vector calculus ,harmonic injection techniques are also pointed out. It is difficult to evaluate the best active current waveshaping technique as each technique has its own advantages and disadvantages. Similarly, as expected no single SMR configuration is ideal for all applications. However, knowing the application requirements , affordable number of components, desired efficiency, this paper enables the design engineer to make a good choice for the required application.

Table 2.

Configurations	Diodes	MOSFETs	Inductors AC side Dc side	Capacitor banks
Fig. 4	15	3	3	1
Fig. 5 (a)	7	1	3	1
(b)	7	1	3	4
(c)	7	1	3	2
(d)	7	1	3	2
(e)	8	1	3	2
(f)	8	1	3	5
(g)	3	3	3	1
(h)	8	4	3	3
(i)	8	2	3	1
Fig. 6 (a)	6	6	3	2
(b)	6	6	3	1
(c)	6	6	3	1
(d)	6	6	3	1
Fig. 7 (a)	8	2	6	2
(b)	8	2	2	4

7. Acknowledgment

This work is supported from grants received from the Hydro-Québec/NSERC, Canada, Industrial Research Chair at the Département de génie Électrique, University du Québec à Trois-Rivières, Québec, Canada.

References

1. IEEE standard 519
 2. IEC 555-2
 3. GAUGER, D., *et al.*
 4. MANIAS, S., ZIOGAS, P. D. AND OLIVIER, G.,
 5. STIHI, O AND OOI, B. T.,
 6. Dubey, G. K.,
 7. DUBEY, G. K., DORADLA, S. R., JOSHI, A. AND SINHA, R. M. K.,
 8. FUJITA, H. AND AKAGI, H.
 9. Kanetkar, V. R., MANJUSHA DAWANDE, DUBEY, G. K.,
 10. Rajagopalan, V.,
 11. Rajagopalan, V.,
 12. Dewan, S. B.,
 13. PRASAD, A. R., ZIOGAS, P. D. AND MANIAS, S.,
 14. VARPORIAN, V. AND Ridley, R. B.,
 15. PRASAD, A. R., ZIOGAS, P. D. AND MANIAS, S.,
 16. PRASAD, A. R., ZIOGAS, P. D. AND MANIAS, S.,
- EEE Recommended practices and requirements for harmonic control in electric power systems, 1992 by IEEE Industry applications society/power engineering society, April 12, 1993.
- Draft-Revision of publication IEC 555-2: "Harmonics, Equipment for connection to the public low voltage system," IEC SC 77A, 1990.
- A three phase off line switching frequency power supply with unity power factor and low TIF, *IEEE INTELC-86, Conf. Rec.*, 1986, pp. 115-121.
- An ac to dc converter with improved input power factor and high power density, *IEEE Trans. Industry applications*, Vol. IA-22, 6, 1986, pp. 1073-1081.
- A single phase controlled current PWM rectifier, *IEEE Trans. on Power Electronics*, 4, 1988, pp. 453-459.
- Power semiconductor controlled drives, Prentice Hall, Englewood Cliffs, 1989.
- Thyristorised power controllers," Wiley eastern ltd. 1986.
- A practical approach to harmonic compensation in power systems-series connection of passive and active filters, *IEEE Trans. on Industry applications*, Vol. 27, 6, 1991, pp. 1020-1025.
- Recent advances in synchronous link converters, *IETE book series, Vol.1, Power electronics and drives*, 1993, pp. 131-151.
- Computer aided analysis of power electronics systems, Dekker publication, New-York, 1987.
- Modeling and simulation of power electronic converters for power supplies, *IEEE IECON Conf. Rec.1995*, pp. 27-32.
- Optimum input and output filters for a single phase rectifier power supply, *IEEE Trans on Industry applications*, Vol. IA-17, 3, 1989, pp. 282-288.
- A novel passive waveshaping method for single phase diode rectifiers, *IEEE Trans on Industrial Electronics*, Vol IE-37, 6, 1990, pp. 521-530.
- A simple scheme for unity power factor rectification for high frequency ac busses, *IEEE Trans on Power Electronics*, Vol.5, 1, 1990, pp. 77-87.
- A passive input current waveshaping method for three phase diode rectifiers, *IEEE APEC-91 Conf. Rec.*, 1991, pp. 319-329.
- A comparative study of SMR converters with and without active input current waveshaping, *IEEE Trans on Industrial Electronics*, Vol. IE-35, 3, 1988, pp. 461-468.

17. Henze, C. P. AND Mohan, N., A digitally controlled ac to dc power conditioner that draws sinusoidal input current, *IEEE PESC-86 Conf. Rec.*, 1986, pp. 531–540.
18. RICHARD REDL AND SOKAL, N. O., Current mode control, five different types used with the three basic classes of power converters: small signal ac and large signal dc characterization, stability requirements and implementation of practical circuits, *IEEE PESC-85, Conf. Rec.*, 1985, pp. 771–785.
19. Sen, K. K. AND Emanuel, A. E., Unity power factor single phase power conditioner, *IEEE PESC-87, Conf. Rec.*, 1987, pp. 516–524.
20. ITOH, R. AND ISHIZAKA, K., Single phase sinusoidal converter using MOSFETs, *IEE proceeding*, Vol. 136, Pt. B, 5, 1989, pp. 237–242.
21. MANIAS, S., Novel full bridge semicontrolled switch mode rectifier, *IEE Proceedings*, Vol. 138, Pt.B, 1991, pp. 252–256.
22. MANJUSHA DAWANDE, Switch mode power rectification, *Ph.D. thesis*, IIT Kanpur, India, 1994.
23. MARTINEZ, R. AND ENJETI, P. N. A high performance single phase rectifier with input power factor correction, *IEEE Trans. on Power Electronics*, Vol. 11, 2, 1996, pp. 311–317.
24. MANJUSHA DAWANDE, KANETKAR, V. R., AND DUBEY, G. K. Three phase switch mode rectifier with hysteresis current control, *IEEE Trans. on Power Electronics*, Vol. 11, 3, 1996, pp. 466–471.
25. SIMARD, R. AND RAJAGOPALAN, V., Convertisseur CA-CC à courant d'entrée sinusoidal amélioré, *Canadian Journal Elect. And Computer Engg.*, Vol. 19, 3, 1994, pp. 113–121.
26. BUSSE, A. AND HOLTZ, J., Multiloop control of unity power factor fast switching ac to dc converter, *IEEE PESC-82, Conf. Rec.*, 1986, pp. 171–179.
27. STREIT, R. AND TOLLIK, D., High efficiency telecom rectifier using a novel soft switched boost based input current shaper, *IEEE INTELEC Rec.*, 1991, pp. 720–726.
28. Hua, G., LEU, C. S. AND LEE, F. C., Novel zero voltage transition PWM converters, *IEEE PESC Rec.*, 1992, pp. 55–61.
29. FERRARI DE SOUZA, A. AND BABRI, I., A new ZVS PWM unity power factor rectifier with reduced conduction losses, *IEEE Trans. on Power Electronics*, Vol. 10, 6, 1995, pp.746–752.
30. MANJUSHA DAWANDE AND DUBEY, G. K. Single phase switch mode rectifiers, *IEEE PEDES-96 Conf. Rec.*, 1996, pp. 637–643.
31. ITOH, R. AND ISHIZAKA, K., Single phase sinusoidal rectifier with step up/down characteristics, *IEE proceedings*, Vol. 138, Pt.B, 6, 1991, pp. 338–344.
32. Boys, J. T. AND GREEN, A. W., Current forced single phase reversible rectifiers, *IEE*, Vol. 136, Pt.B, 5, 1989, pp. 205–211.
33. KAZERANI, M., JOOS, G. AND ZIOGAS, P. D. A novel active current waveshaping technique for solid state input power factor conditioner, *IECON-89 Conf. Rec.*, Vol. 1, 1989, pp. 99–105.
34. KAZERANI, M., JOOS, G. AND ZIOGAS, P. D., Programmable input power factor correction methods for single phase diode rectifier circuits, *IEEE APEC-90, Conf. Rec.*, 1990 pp. 177–184.

35. DIXON, J. W. AND OOI, B. T., Indirect current control of a unity power factor sinusoidal boost type three phase rectifier, *IEEE Trans. on Industrial Electronics*, Vol. IE-35, 4, 1988, pp. 508–515.
36. DIXON, J. W. AND OOI, B. T., Dynamically stabilised indirect current controlled SPWM boost type three phase rectifier, *IEEE Industrial application Soc. Annual meeting Conf. Rec.*, 1988, pp. 700–705.
37. KOCHER, M. J., AND STEIGERWALD, R. L. An ac to dc converter with high quality input waveforms, *IEEE Trans on Industry Applications*, Vol.IA-19, 4, 1983, pp. 586–599.
38. PRASAD, A. R., ZIOGAS, P. D. AND MANIAS, S., An active power factor correction technique for three phase diode rectifiers, *IEEE Trans. on Power Electronics*, Vol. 6, 1, 1991, pp. 83–92.
39. MANJUSHA DAWANDE AND DUBEY, G. K., Programmable input power factor correction method for SMRs, *IEEE Trans on Power Electronics*, Vol. 11, 4, 1996, pp. 585–591.
40. KOLAR, J. W., ERTL, H., AND ZACH, F. C., Space vector based analytical analysis of the input current distortion of a three phase discontinuous mode boost rectifier system, *IEEE Trans. on Power Electronics*, Vol. 10, 6, 1995, pp. 733–745.
41. KOLAR, J. W., ERTL, H., AND ZACH, F. C., A comprehensive design approach for a three phase high frequency single switch discontinuous mode boost power factor corrector based on analytically derived normalized converter component ratings, *IEEE Trans. on Industry Application*, Vol. 31, 3, 1995, pp. 569–582.
42. KOLAR, J. W., ERTL, H., AND ZACH, F. C., Analysis of different current control concepts for forced commutated rectifier(FCR), *PCI Proc.*, 1986, pp. 195–217.
43. TOU, M., HADDAD, K., OLIVIER, G. AND RAJAGOPLAN, V., Analysis and design of single controlled switch three phase rectifier with unity power factor and sinusoidal input current, *IEEE APEC-1995, Conf. Rec.*, Vol. II, pp. 856–862.
44. ISMAIL, E. H. AND ERICKSON, R., Single switch three phase PWM low harmonic rectifier, *IEEE Trans. on Power Electronics*, Vol. 11, 2, 1996, pp. 338–346.
45. SALMON, J. C., Reliable 3-phase PWM boost rectifiers employing a stacked dual boost converter subtopology, *IEEE Trans. on Industry Applications*, Vol. 32, 3, 1996, pp. 542–551.
46. NED MOHAN, A novel approach to minimize line current harmonics in interfacing power electronics equipment with 3-phase utility systems, *IEEE Power Engineering Society Meeting*, 1992, pp. 1–7.
47. NAIK, R., RASTOGI, M. AND MOHAN, N., Third harmonic power electronics interface with three phase utility to provide a regulated dc output and to minimize line current harmonics, *IEEE IAS Annual meeting Conf. Rec.*, 1992, pp. 689–694.
48. MOHAN, N., RASTOGI, M. AND NAIK, R., Analysis of a new power electronics interface with approximately sinusoidal three phase utility currents and a regulated dc output, *IEEE Trans. on Power delivery*, 1993, pp. 540–546.
49. RASTOGI, M., MOHAN, N. AND HENZE, C. P., Three phase sinusoidal current rectifier with zero current switching, *IEEE Trans. on Power Electronics*, Vol. 10, 6, 1995 pp. 753–759.
50. RUSTOGI, M., NAIK, R. AND MOHAN, N., A comparative evaluation of harmonic reduction techniques in three phase utility interface of power electronics loads, *IEEE Trans. on Industry Applications*, Vol.30, 5, 1994, pp. 1149–1155.