

## CIRCULATING CURRENTS IN WAVE-WOUND ARMATURES.

*By F. N. Mowdawalla and G. K. Pradhan.*

### SYNOPSIS.

Alternating currents circulating in the wave-wound armatures under certain conditions have been observed and traced to the unbalancing of armature electromotive forces due to the presence of dummy conductors. The effect of these circulating currents on the wave shape of the resultant current flowing through the armature conductors under different conditions is studied, and the variation of the resultant current with the position of the coils observed. The circulating currents, however, are found to be so small that the increased rate of heat-production due to them would not be sufficient to affect the capacity of the machine.

It is well known that if the winding of the armature of a rotary converter is cut and the current flowing through it studied by means of an oscillograph, various shapes of current waves are observed depending on the position of the coil cut relatively to the points of connection of the winding to the slip rings. All these wave shapes, however, resemble each other in this respect that they result from the superposition of the direct current drawn from the machine, on the alternating current fed into it through the slip rings, and are due to the fact that both these currents traverse the same winding. During an investigation of the commutating conditions in a rotary converter, a current wave of similar characteristics (Plate 1) was observed even when the machine was running as a direct current motor. Since alternating current was neither supplied to nor drawn from the machine, this points to the existence of an alternating current circulating in the local circuit of the armature. No reference to the existence of these peculiar wave forms or of alternating currents circulating in direct current armatures is to be found in the technical literature. This is probably due to the fact that current waves in direct current armatures are not generally suspected to be capable of assuming shapes other than rectangular and that these peculiarities are to be met with only in special machines.

The machine under test was a 4-pole, interpole type rotary converter with a rated output of 4 to 5 kw. at 100 to 130 volts when

running at 750 r.p.m. It has a wave-wound armature with 582 conductors placed in 49 slots and connected to a commutator of 97 segments. This is equivalent to a distribution of 12 conductors per slot, the spaces corresponding to 6 of these conductors being left blank and filled with dummy conductors for the purpose of obtaining a re-entrant winding. There are 97 active armature coils each consisting of 6 conductors, and one dummy coil. The armature is fitted with 6 slip rings so connected that the machine may be used either as a 2 or 3-phase converter (see Fig. 1). It is also provided with a search coil of 3 turns, the ends of which are brought out to two additional slip rings. For the purpose of the investigation the winding was cut open at two diametrically opposite points,  $a$  and  $b$ , and so arranged that the cut ends of either of these coils could be connected to the search coil slip rings after disconnecting the search coil from them. By this means the wave shapes of current in these coils could be studied by connecting an oscillograph to these slip rings.

Fig. 2 is the diagram of connections of the machine when running as motor. With the oscillograph connected to the coil  $a$  and the machine running light at 750 r.p.m. with 110 volts across the armature and 0.95 ampere through the field, the wave shown in Fig. 3 $a$  was obtained. This wave may be regarded as the resultant of (1) the dotted rectangular wave corresponding to the direct current supplied to the armature and (2) the chain dotted wave representing the alternating current circulating in the winding, there being no external alternating current (Fig. 3 $b$ ).

The circulating component must be due to an unbalancing of the electromotive forces induced in the two halves of the armature winding and this unbalancing may be explained by:—

(1) An inequality of the main flux under cover of the different poles due either to a difference in the number of turns of the field coils or to unequal lengths of the air gaps, or

(2) An asymmetry of the armature winding.

If the circulating current were due to an inequality of the flux the difference in the electromotive forces induced in the two halves of the armature winding would remain constant, so that the circulating current would remain constant in magnitude and direction at all instants and for all positions of the armature, and the superposition of this current on the supply current would give rise to a wave similar to that shown in Fig. 4.

The circulating current must therefore be due to an asymmetry of the armature winding and it can be traced to the presence of dummy conductors. Fig. 5 explains diagrammatically the cause of the

unbalancing of the armature electromotive forces. Each black dot represents a normal element of the armature winding consisting of two coils (12 active conductors) included between two adjacent commutator segments, while the corresponding circle  $d$  represents the element containing the dummy conductors. It is apparent that equal and opposite electromotive forces will be induced in each pair of the diametrically opposite elements and that they will therefore balance each other between the brushes BB. This however does not hold good in the case of the elements  $cd$ . Since  $d$  contains only 6 active conductors instead of 12, the electromotive forces induced in  $c$  and  $d$  are not equal and an unbalancing of these arises, that half of the armature containing the element  $c$  having always a higher electromotive force than the other half. Since the unbalancing is due to the electromotive force induced in 6 of the conductors of the element  $c$  and since the instantaneous value of this is proportional to the rate at which these conductors cut the flux in the air gap, the shape of the wave of unbalanced electromotive force should be similar to that of the flux density in the air gap of the machine.

In order to isolate the circulating current the machine was run light as generator at a speed of 750 r.p.m. with an excitation of 0.95 ampere. The oscillograph was connected as shown in Fig. 6a, and the wave shown in Plate 2 was obtained. This proves the existence of the circulating current although the wave shape obtained does not by any means resemble that of the flux distribution in the air gap of the machine. As it was thought that this difference might be due to the self-induction of the armature the experiment was repeated after inserting 50 ohms in the oscillograph circuit in order to swamp the effect of this self-induction (Fig. 6b) and the wave shown in Plate 3 was obtained. This exactly resembles the shape of flux distribution (Plate 4) obtained by running the machine under similar conditions and connecting the oscillograph to the search coil as shown in Fig. 6c. A self-induction of 0.1 henry was next inserted in the search coil circuit in addition to the 50-ohm resistance and the wave shown in Plate 5 was obtained. The similarity of this to the wave shown in Plate 2 proves that the distortion of the wave of circulating current was caused by the self-induction of the circuit.

It will be seen that the waves shown in Plates 3 and 4 are not only similar in shape, but that their amplitudes are also exactly equal. Since the resistance of the circuit in both cases was 50 ohms, this indicates an equality of the electromotive forces producing the currents, and since the search coil as well as the dummy coil consists of 3 turns each it proves that the circulating current is caused by an unbalancing of the armature electromotive forces due to the absence of 3 active coils substituted by the dummy coils. This is further proved by a

similarity of wave shapes obtained under similar conditions with circuits shown in Figs. 6*b* and 6*c*, but with interpoles instead of the main poles excited.

Returning to the case of the machine working as a motor, the effect of variation of excitation was next studied and the four curves shown in Fig. 7 were obtained with the machine running light with 110 volts across its armature and excitations of 0.5, 0.97, 2.0 and 2.75 amperes respectively through the field. All these curves were obtained with the same value of resistances  $R_1$  and  $R_2$  in the oscillograph circuit (Fig. 2) and therefore give instantaneous values of the current to the same scale. It will be observed that while the maximum positive and negative values of the waves decrease with increasing excitation the sum of  $a$  and  $b$ , which is equal to twice the amplitude of the circulating current, remains constant in all cases. In other words, the direct current component of the wave decreases with increasing excitation, while the alternating component remains unchanged. This is due to the fact that with increasing excitation smaller input currents are capable of producing the required driving torque. At the same time, so long as the supply potential difference remains constant, the electromotive force induced in each conductor must also remain constant, and since the circulating currents are proportional to the electromotive force induced in a coil of 6 conductors, these also must remain unchanged.

In Fig. 8 the curves were obtained with a constant excitation of 0.95 ampere and a supply potential difference of 80 and 140 volts respectively. It will be seen that the alternating current component increases, as would be expected, in direct proportion to the voltage. The slight increase in the direct current component indicated by an increase of the length  $c$  is due to the fact that a larger driving torque becomes necessary at a higher voltage on account of the increase of speed.

Fig. 9 represents curves obtained with a constant supply potential difference, constant excitation and increasing load on the motor, the currents supplied to the motor being 10 and 20 amperes respectively. It will be observed that, as expected, the alternating component remains constant while the direct current component increases with increase of load. It must be mentioned that these curves were obtained with a different value of the resistances  $R_1$  and  $R_2$  in the oscillograph circuit and that their scale therefore differs from that of the previous curves.

All the above curves are concave towards the base line and have a hollow in the positive and negative halves. This results from the alternating current component opposing the direct current component

over the greater portion of the cycle (see Fig. 3*b*). If, however, one of these components is reversed, their relative positions would be as shown in Fig. 10*a* and a wave having a hump instead of a hollow in the positive and negative halves would result (Fig. 10*b*). This would happen if the machine was worked as generator instead of motor, for in that case the direct current component would be reversed. Plate 6 represents the current through the armature coil *a* when the machine was run as generator at 750 r.p.m. and delivered a current of 7.5 amperes under an excitation of 0.95 ampere. The effect of increase of load is found to be the same as in the case of the motor. The direct current component increases in magnitude while the circulating component remains the same.

All the above curves represent currents flowing under different conditions through the coil *a* (Fig. 1). Since the shape of the wave of the resultant current depends on the phase difference between the component waves and since this phase difference varies with the position of the coil with respect to the dummy coil, the resultant wave shape will be different for different coils. In any coil the direct current component of the current wave undergoes reversal at the instant the coil under consideration passes under the brushes. This instant would therefore vary with the position of the coil. On the other hand, the circulating component undergoes reversal when the dummy coil passes under the brushes and this occurs simultaneously in all coils. Considering the coil *a* in Fig. 11, when the machine is running as motor in the clockwise direction, the direct current component of the current through the coil would undergo reversal a little in advance of the alternating current component. At the same time the latter will, over the greater portion of the cycle, be in opposition to the former and consequently the wave shape *a* (Fig. 11) would result. In the coil *b*, the reversal of the direct current component would be retarded by  $90^\circ$  and the wave shape would be as shown in *b*. In the coil *c*, this would be  $180^\circ$  behind that in *a* and the curve *c* would result.

The current through the coil *b* (Fig. 1) was also studied and Plate 7 represents the current wave obtained when the machine was working as motor on no load at 750 r.p.m. with 110 volts across the armature and 0.95 ampere through the field. It will be seen that this closely resembles the curve *c* in Fig. 11. On the other hand when the machine was run as generator at 750 r.p.m. and delivered a load-current of 7.5 amperes with an excitation of 0.95 ampere, the curve shown in Plate 8 was obtained. It was not considered advisable to cut the armature in more than two places, but it may be taken that if the coil were cut in a position corresponding to *b* in Fig. 11, a corresponding curve would be observed.

The effect of load conditions on the magnitude and shape of the circulating current wave (Plate 2) was next investigated. As it was not possible to obtain corresponding curves for pure circulating current waves with the machine working either as motor or generator under load, it was decided to study the change brought about by load in the search coil curve (Plate 5). Plate 9 shows the search coil curve with the machine running as generator at 750 r.p.m. with an excitation of 0.95 ampere and delivering an output current of 15 amperes, while Plate 10 shows the corresponding curve with the machine running as motor at the same speed under the same excitation and drawing 15 amperes from the mains at a potential difference of 110 volts. It can be seen that the magnitude of the current is not materially altered, although the shape has appreciably changed. In the motor curve the top of the wave has become flatter while in the generator curve it has become steeper than in Plate 5. This is due to the fact that the air gap flux tends to crowd towards the leading pole tip when the machine is motoring and towards the trailing pole tip when it is generating. Consequently the wave of the induced electromotive force, instead of having a flat top as in Plate 4, will have it sloping down from the leading to the trailing pole tip in the case of the motor and *vice versa* in the case of the generator; it can be readily understood that the current waves resulting from these will be distorted by the self-induction of the circuit into shapes similar to those of Plates 9 and 10.

It has been seen above that the wave shape of the resultant current through the armature varies from coil to coil with the result that the maximum and root-mean-square values of these currents are in some cases greater (Plate 6) and in others less (Plate 1) than if the direct current alone were present. For this reason the rate of heat-production in the armature varies from coil to coil, and differs from the rate at which heat would be generated uniformly in all the coils in the absence of the circulating current. The root-mean-square value of the circulating current is, however, very small and lies in the neighbourhood of 1.6 amperes as compared with 20 amperes for the direct current component under full load conditions. Thus the root-mean-square value of the resultant wave does not, under full load conditions, differ materially from that of the direct current component. Consequently, although the temperature rise of copper in some of the coils does increase as a result of the presence of the circulating current, this increase is too small to affect the load capacity and therefore the size of the machine.

The preceding curves of the current waves should be divided into two groups:—(a) line drawings and (b) plates. The former were obtained by means of an ordinary Duddell Oscillograph of the electromagnetic pattern by tracing the waves on paper on the tracing-

desk of the instrument. Each of these therefore represents the mean of a succession of waves and is thus perfectly smooth and free from the irregular ripples due to variable causes such as changing brush-contact resistance. The following table gives the data of the various quantities referring to these curves :—

TABLE.

Fig. No.	Machine running as	Armature P.D. volts.	Field Current amps.	Speed r.p.m.	Armature Current amps.	Current through cut armature coil amps.	Oscillograph Circuit	
							Shunt $R_1$ (Fig. 2) set at amps.	Resistance in series with strip $R_2$ (Fig. 2) ohms
7a	Motor	110	0.5	1,370	7.0	1.7	2	3
7b	„	110	0.97	750	4.8	1.0	2	3
7c	„	110	2.0	530	3.5	1.0	2	3
7d	„	110	2.75	480	3.4	1.0	2	3
8a	„	80	0.97	550	4.8	0.76	2	3
8b	„	140	0.97	985	4.8	1.33	2	3
9a	„	110	0.97	750	10.0	3.1	10	...
9b	„	110	0.97	750	20.0	6.85	10	...

The plates, on the other hand, are copies of photographs taken by means of a drum film camera on a Duddell 3-element portable oscillograph and represent shapes of single waves obtained under specified conditions. It will be seen that some of these curves have secondary ripples superimposed on the fundamental waves. In some cases these ripples are quite regular (Plates 3 and 4) and these are due to tooth-effect. They are more or less completely smoothed out in Plates 2 and 5 on account of the preponderating self-induction of the corresponding circuits, but are still slightly visible near the crest of the wave. The ripples in Plates 1, 6, 7 and 8 are not so regular and differ, not only in different curves obtained under identical conditions, but also in some cases in the positive and negative half-waves of the same curve. They are probably due to an irregular cyclic variation of the brush-contact resistance caused by vibration of the brushes in their holders.

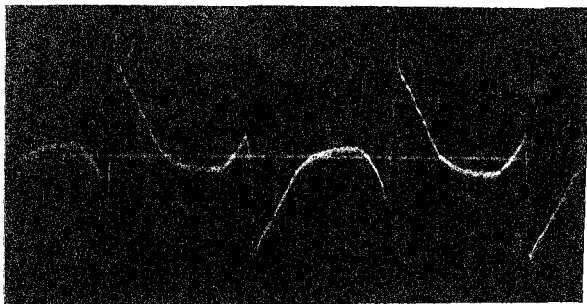
*Department of Electrical Technology,  
Indian Institute of Science,*

[Accepted, 10-8-26.]

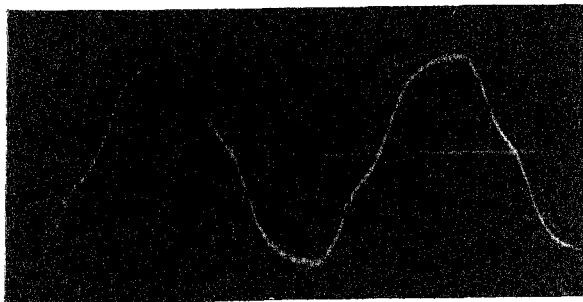
*Bangalore.*

PRINTED AND PUBLISHED  
BY GEORGE KENNETH AT THE DIOCESAN PRESS,  
POST BOX 455, MADRAS--1926. C13540

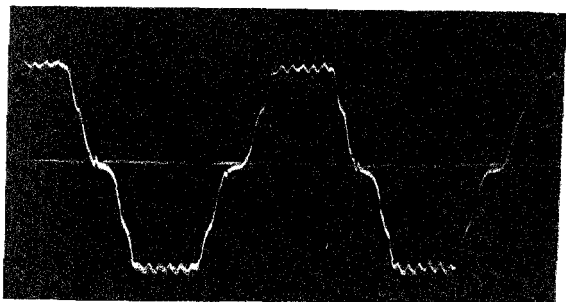




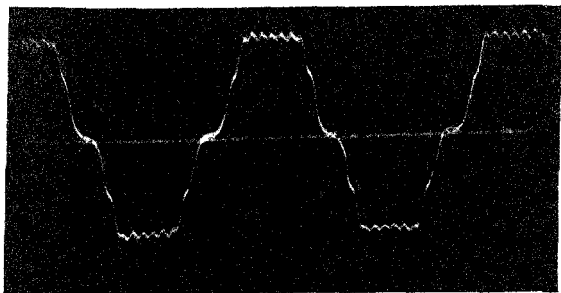
**Plate 1.** *Current through coil a, machine running as a motor on no load.*



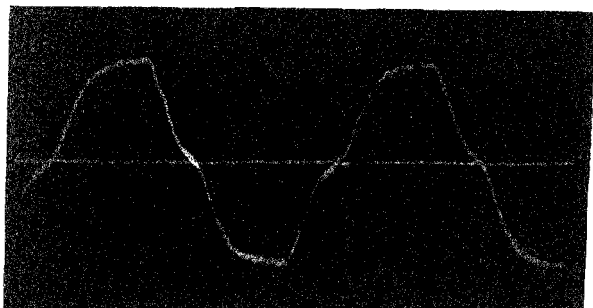
**Plate 2.** *Current through coil a, machine running as generator on no load.*



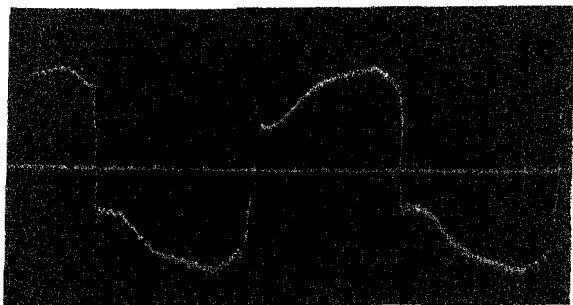
**Plate 3.** *Current throughout coil a, machine running as generator on no load, 50 ohms in oscillograph circuit.*



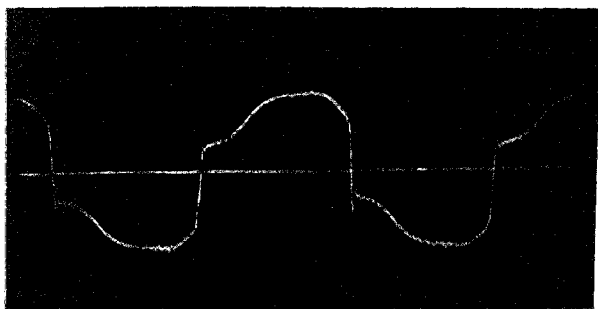
**Plate 4.** *Current through search coil with 50 ohms in series, machine running as generator on no load.*



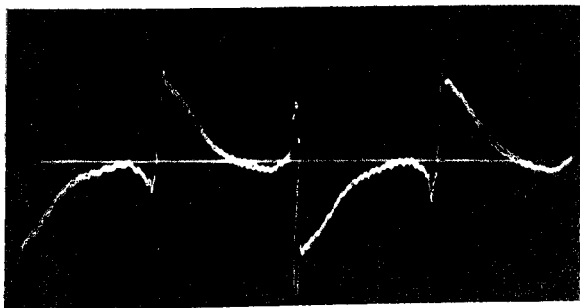
**Plate 5.** *Current through search coil with 50 ohms and 0.1 henry in series, machine running as generator on no load.*



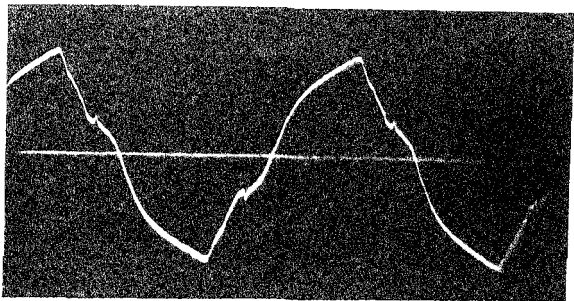
**Plate 6.** *Current through coil a, machine running as generator on load.*



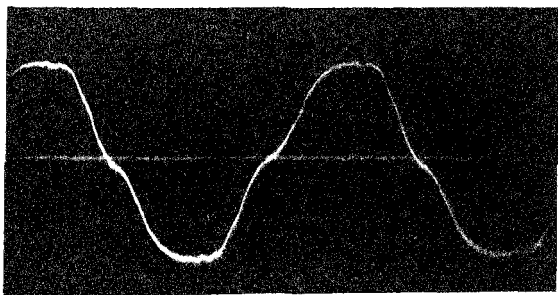
**Plate 7.** *Current through coil b, machine running as motor on no load.*



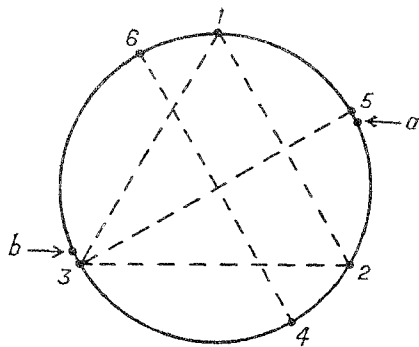
**Plate 8.** *Current through coil b, machine running as generator on load.*



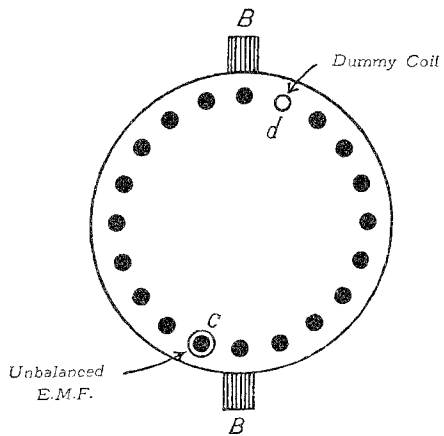
**Plate 9.** *Current through search coil with 50 ohms and 0.1 henry in series, machine running as generator on load.*



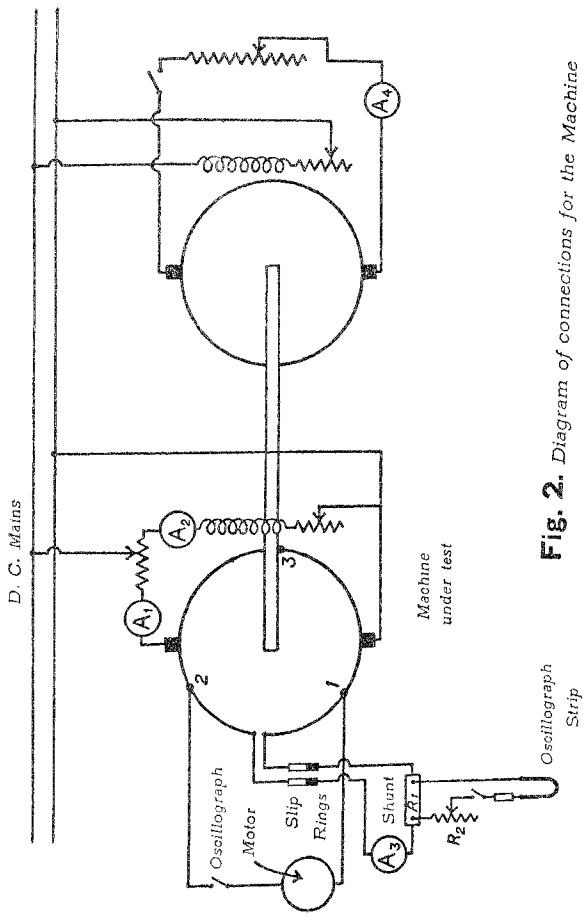
**Plate 10.** *Current through search coil with 50 ohms and 0.1 henry, machine running as motor on load.*



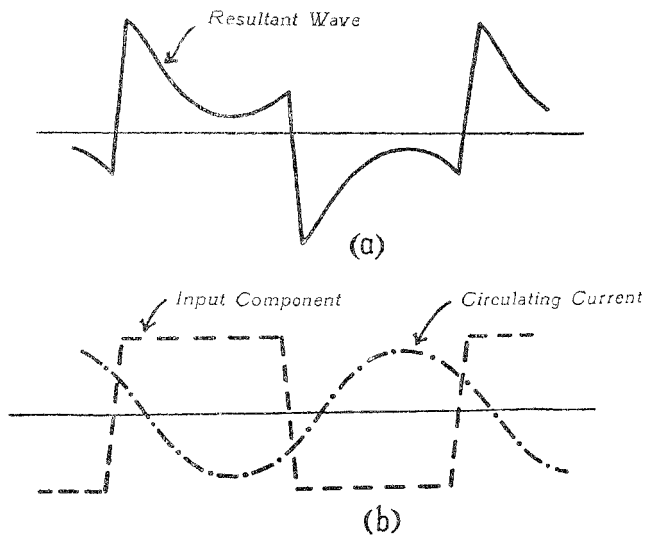
**Fig. 1.** Armature Diagram.



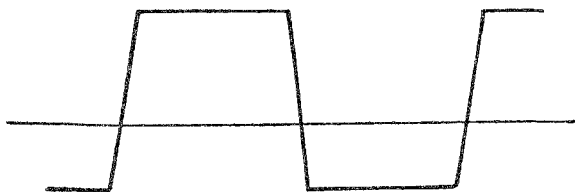
**Fig. 5.**



**Fig. 2.** Diagram of connections for the Machine when running as Motor.

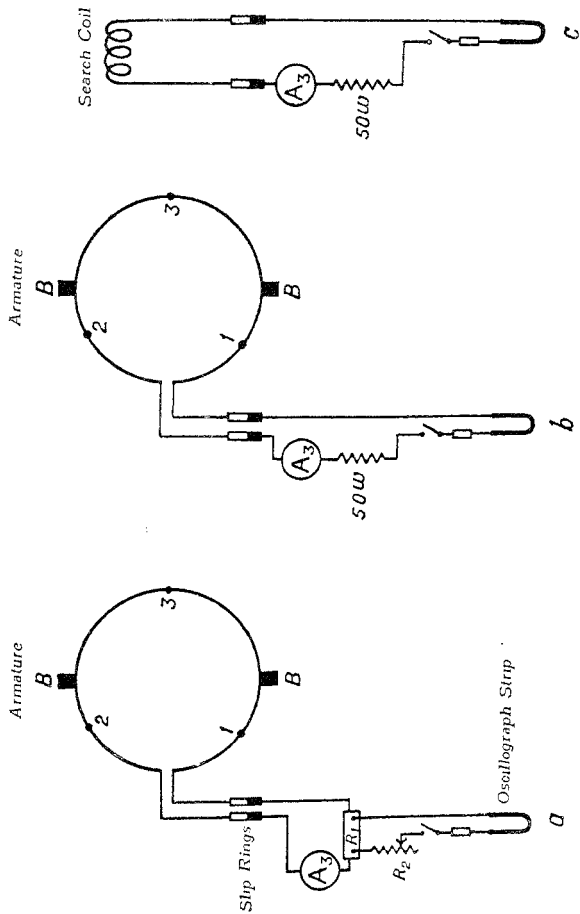


**Fig. 3.** Armature Current Wave and its Components

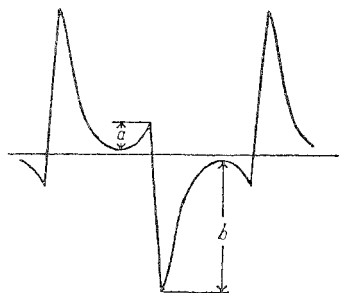


**Fig. 4.** Wave of Current due to unequal Flux under different Poles.

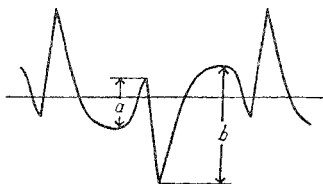




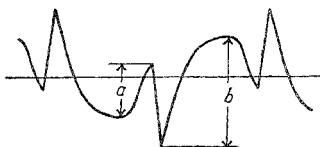
**Fig. 6.** Oscillograph Circuits.



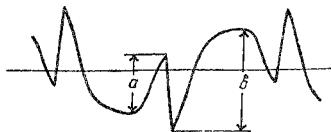
(a) Field Current 0.5 amps



(b) Field Current 0.97 amps.

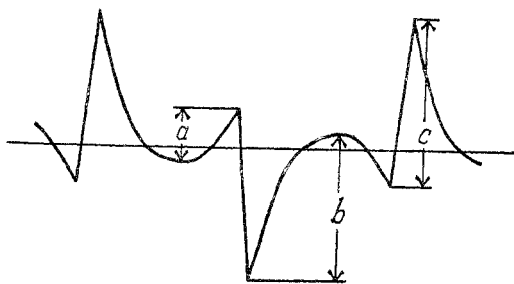


(c) Field Current 2.0 amps.

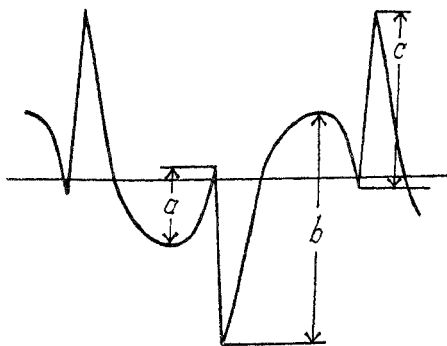


(d) Field Current 2.75 amps.

**Fig. 7.** Variation of Armature Current with Excitation.

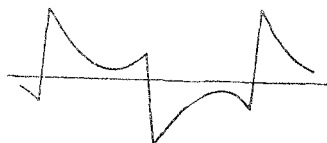


(a)  $P.D. = 80$  volts.

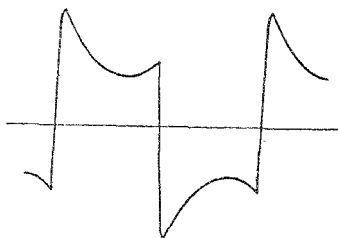


(b)  $P.D. = 140$  volts.

**Fig. 8.** Variation of Armature Current with Impressed P.D.

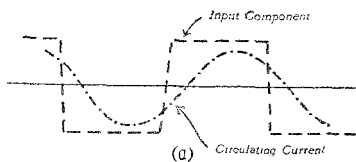


(a) Armature Current 10 amps

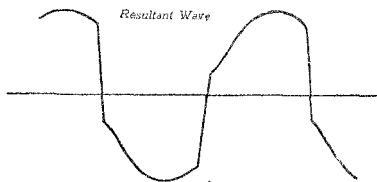


(b) Armature Current 20 amps

**Fig. 9.** Variation of Armature Current with Load.

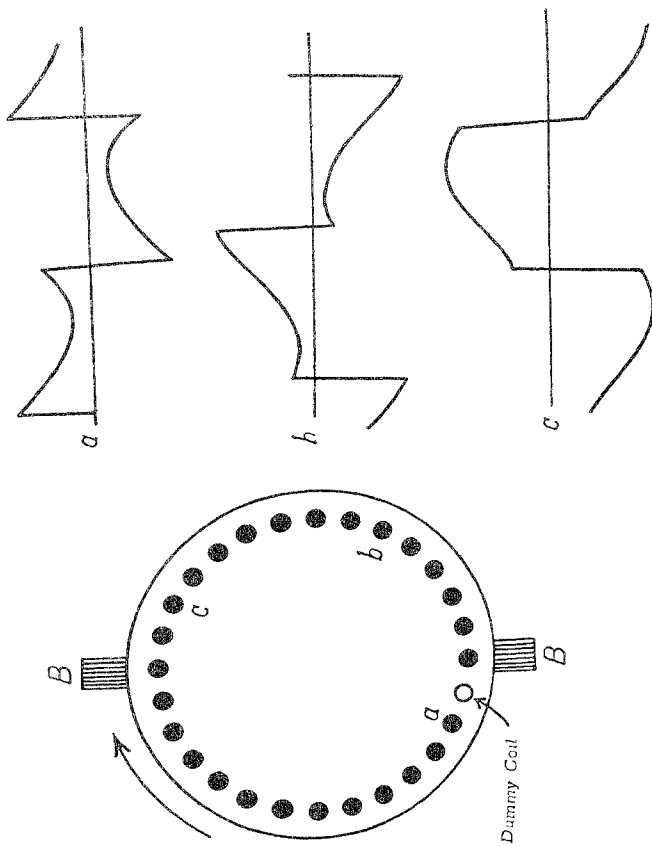


(a) Circulating Current



(b)

**Fig. 10.** Another Wave form of Armature Current



**Fig. 11.** Variation of Wave Shape with position of Coil.