

Experimental and Analytical Investigations of the actions  
taking place in a Synchronous machine during the  
starting period when the starting is effected  
by means of alternating current.

By *A. Hay, D. Sc., M. I. E. E., and F. N. Mowdawalla, M. A., B.Sc.*

INTRODUCTION.

The literature on the subject of the present investigation is somewhat meagre. A rotary converter or synchronous motor not provided with any special starting devices forms, when started from the alternating current side, a type of induction motor whose stator is provided with a polyphase winding, and whose rotor has a single-phase (or single magnetic axis) winding. The earliest reference to this type of motor which the authors have been able to find occurs in a paper published in 1896 by H. Görge,<sup>\*</sup> who describes the peculiar behaviour of such a motor in the neighbourhood of half-synchronous speed, without, however, attempting any explanation of the effects observed. Such an explanation was given in 1898 by F. Eichberg.<sup>\*\*</sup> Nothing further of importance appears to have been published on this subject until comparatively recent times. In 1912, C. J. Fehheimer read a paper before the American Institute of Electrical Engineers on self-starting synchronous motors,<sup>†</sup> in which some attention is given to the occurrences during the starting period; both the paper itself and the discussion thereon serve to emphasise the unsatisfactory state of our knowledge of the occurrences during the starting period. The subject is again dealt with, though in a somewhat cursory manner, by E. Rosenberg, in a paper on self-synchronising machines read in 1913 before the Institution of Electrical Engineers.<sup>‡</sup>

<sup>\*</sup> H. Görge: Ueber Drehstrommotoren mit verminderter Tourenzahl. *Elektrotechnische Zeitschrift*, Vol. 17, p. 517 (1896).

<sup>\*\*</sup> F. Eichberg, *Zeitschrift für Elektrotechnik* (Wien), Vol. 16, p. 578 (1898).

<sup>†</sup> C. J. Fehheimer, *Proceedings of the American Institute of Electrical Engineers*, Vol. 31, pp. 305 and 1942 (1912).

<sup>‡</sup> E. Rosenberg: Self-synchronising Machines. *Journal of the Institution of Electrical Engineers*, Vol. 51, p. 62 (1913).

The latest contribution to the subject is a paper by F. D. Newbury on "The Behaviour of Synchronous Motors during Starting" read before the American Institute of Electrical Engineers in June 1913.<sup>\*†</sup> This paper contains a large number of interesting oscillograms taken during the starting period; the method of investigation is, however, totally different from that adopted in the present paper.

<sup>\*†</sup> *Transactions of the American Institute of Electrical Engineers* Vol. 32, p. 1509.

## I. GENERAL METHOD OF CONDUCTING EXPERIMENTS.

The investigations about to be described have for their object the determination of the stator, p. d. or current, the power supplied to the stator, the e. m. f. induced in the rotor winding when on open circuit, and the current in the rotor when its winding is closed — all expressed as functions of the rotor speed, when the current or p. d. — as the case may be — supplied to the stator is maintained at a constant value. Incidentally, an investigation was carried out of the effect of eddy-currents in the solid portions of the rotor on the magnetic flux distribution in the pole-cores.

Two machines were experimented on. One of these was a 50 kw., 25-cycle, three-phase alternator, whose magnetic circuit is shown in Fig. 1. The machine is designed for a terminal voltage of 130 and a speed of 500 r. p. m. The armature is star-connected. Each phase consists of 36 conductors. The field winding is intended to be supplied at 50 volts; each field coil contains 390 turns.

The other machine was a three-phase, 100-volt, 50-cycle,  $7\frac{1}{2}$  b. h. p. induction motor designed for a speed of 1450 r. p. m., and having a wound rotor. Its magnetic circuit is shown in Fig. 2. Both stator and rotor windings are star-connected; each stator phase contains 20 conductors, and each rotor phase 21 conductors. The object of choosing an induction motor for some of the experiments was to eliminate the complications which arise on account of eddy-currents in the solid cores of the synchronous machine.

In all the experiments, the power supplied to the stator was such that at no speed was it sufficient to provide a torque which would enable the rotor to run against the resistances to its motion, so that additional mechanical power was necessary in order to keep the rotor running. This additional power was supplied by a continuous current motor coupled to the rotor. In this way, stability of running could be secured at all speeds.

The power supplied to the stator was measured by a Drysdale standard polyphase wattmeter. Weston instruments were employed for the measurement of voltages and currents. Speeds considerably removed from either half-synchronism or

full synchronism were measured by a speed counter, while in the immediate neighbourhood of either half or full synchronism the measurement was carried out by a stroboscopic method, a suitable disc being mounted for this purpose on the alternator shaft.

## 2. EXPERIMENTS WITH SYNCHRONOUS MACHINE.

The arrangement of connections employed in the experiments with the synchronous machine is shown in Fig. 3, which is self-explanatory.

*A. Experiments at constant stator current.* Several sets of experiments were carried out with the stator current maintained at a constant value. The results of these experiments are shown graphically in the accompanying curves. In Fig. 4 are given curves showing the variations of the p. d. across the stator terminals, the total power supplied to the stator, and the e. m. f. induced in the rotor or field winding when the stator current is maintained at a constant value, the frequency (25) being the normal frequency of the machine. There is, it will be noticed, a slight hump in the stator p. d. curve, which, however, keeps fairly level until not far from the speed of synchronism, when it begins to rise somewhat steeply. The variations in the stator power curve are more pronounced, there being a very decided hump before the speed of half-synchronism is reached, and the curve continuing on its downward course beyond half-synchronism, passing through a minimum and then rising fairly rapidly to a maximum, beyond which there occurs a very steep drop as synchronism is approached. The e. m. f. induced in the field winding also exhibits remarkable variations, passing through a minimum near half-synchronism and a maximum between half and full synchronism, to drop to a value which closely approaches zero at full synchronism.

In the curves of Fig. 4, the speed was not allowed to exceed the normal speed of synchronism (500 r p. m.). As it was thought desirable to extend the investigation to hypersynchronous speeds, and as such an extension presented difficulties on account of considerations of mechanical safety so long as the frequency was maintained at its normal value, a new set of readings was obtained at half the normal frequency. The results are exhibited in Fig. 5. The speed was carried up to a negative slip of 100 per cent. The general shape of the curves below the new speed of synchronism (250) is the same as that of the curves of Fig. 4. It will be immediately noticed that the curves exhibit a marked dissymmetry about the ordinate of synchronous speed. The least departure from symmetry is exhibited by the



stator p. d. curve. The discontinuity (shown by a dotted line) in the power curve at synchronism is due to the sudden reversal of the hysteresis torque as the rotor passes through synchronism — a well-known effect in induction motors. The field e. m. f. curve exhibits the same depression as before in the neighbourhood of half-synchronism, though this depression is not quite so strongly marked as in the case of the higher frequency curve of Fig. 4.

In Fig. 6 are shown curves obtained at the lower frequency of 12.5, but *with the field circuit closed*. As might have been anticipated, owing to the more powerful reaction due to the closed field circuit, all the curves are more highly distorted than those obtained by running with the field circuit open.

B. *Experiments at constant stator p. d.* In Fig. 7. are given curves obtained at the normal frequency of 25, the terminal stator p. d. being maintained at the constant value of 15 volts. The general shape of the curves is similar to that obtained by maintaining the stator current constant, but the humps on the curves are more strongly marked.

C. *Experiments on the effect of eddy-currents in the solid portions of the magnetic circuit in modifying the flux distribution in the poles.* Owing to the demagnetising effect of the eddy-currents induced in the poles and in the steel hub on which they are mounted, the magnetic flux which enters the poles from the armature is more or less thrust aside as it passes down the pole, crossing the interpolar spaces and giving rise to considerable variations in the total flux distributed over the cross-section of the pole at different depths, as we proceed down its axis. In order to investigate this effect quantitatively, a series of search coils of thin wire were wound round one of the poles of the machine at different depths, and the e. m. f. s. induced in the coils were determined. The arrangement of the search coils is shown in Fig. 8. By temporarily disconnecting the slip-rings from the field winding, and connecting them to the ends of any search coil, the e. m. f. in that coil could be determined. The results of one such set of measurements are shown in Fig. 8. All the curves exhibit the characteristic depression in the neighbourhood of half-synchronous speed, and it will be noticed that the falling off in the total flux as we proceed down the pole is quite appreciable.

The e. m. f. induced in an exploring coil surrounding the pole core is a measure of the maximum value of the surface integral of the magnetic induction over the cross-section of the pole corresponding to the position of the exploring coil. It takes

no account of the instantaneous distribution of the flux, which must be one of great complexity, owing to the phase differences which must exist between the inductions in successive tubular layers surrounding the axis of the pole core and situated at different distances from it.

### 3. EXPERIMENTS WITH INDUCTION MOTOR.

The eddy currents in the solid poles of the synchronous machine giving rise to disturbances of a somewhat complicated nature, it was thought desirable to carry out some experiments with a simpler type of motor having a polyphase stator winding and a single-phase rotor winding. For this purpose, the induction motor already alluded to was employed. The arrangement of connections is shown in Fig. 9, and the results of the experiments are given in Figs. 10 to 14.

Fig. 10 shows the results obtained by keeping the rotor entirely open-circuited. The stator current was maintained at a constant value of 14 amps., the frequency being 25 (this corresponds to a synchronous speed of 750 r p. m.). The slight rise in the stator p. d. with increasing speed is accidental, and is due to a slight rise of frequency during the period of test. The rotor e. m. f. curve is — as might have been expected — symmetrical about the ordinate of synchronous speed.

The curves of Fig. 11 were obtained by closing the circuits of the three rotor phases through an external noninductive three-phase resistance. The stator p. d. and rotor current curves are roughly symmetrical about the ordinate of synchronous speed.

Figs. 12, 13 and 14 have reference to a single-phase or single magnetic axis rotor winding. In the case of Fig. 12, two rotor phases connected in series were closed through an external resistance of 8.84 ohms; in the case of Fig. 13, this resistance was reduced to 1.84 ohms; while Fig. 14 refers to a dead short-circuit of the two phases in series. In all three cases, the appearance of a hump on the curve of rotor current is noticeable; and the hump becomes more marked as the condition of dead short-circuit is approached. The rotor current curves are seen to resemble, in general appearance, the field current curves of the synchronous machine when the field is kept short-circuited, and the most striking feature of such curves is the presence of a hump on the portion of the curve lying to the left of the point of synchronous speed, and its absence in the portion of the curve lying to the right of that point. The hump in the induced current curve corresponds to the hump in the induced e. m. f. curve, such as that shown in Fig. 4.

#### 4. STUDY OF STATOR POWER CURVES.

The stator power curves are of very considerable interest as throwing light on the behaviour of the machine in the neighbourhood of half-synchronism. An examination of these curves shows that, *whereas there is always a discontinuity at the point of synchronism, no such discontinuity occurs at half-synchronism.* This remark is equally applicable to the synchronous and to the induction machine, and its significance will appear presently. A discontinuity in the stator power curve could only result from a sudden change of rotor torque. Such a change occurs at synchronism. At half-synchronism, however, the power curve changes in a perfectly continuous manner, and the steady decrease and ultimate reversal of the rotor torque as half-synchronism is passed also take place in a correspondingly continuous manner. This conclusion is also fully borne out by the behaviour of the machines in the course of the experiments, no difficulty whatever being experienced in running either machine in the immediate neighbourhood of half-synchronous speed. The experiments therefore show conclusively that *during the starting period a synchronous machine does not show any tendency to become locked into half-synchronism.*

Special attention is drawn to this point, as some comparatively recent statements\* show that entirely erroneous notions prevail on this subject. It has been asserted that a synchronous machine does tend to lock into half-synchronism, and attempts have even been made to account for this behaviour. Such statements obviously arise from the fact that in the immediate neighbourhood of half-synchronism there is a rapid (but perfectly continuous) decrease and, in some cases, actual reversal of the rotor torque which tends to make the machine run somewhere in the neighbourhood of (but by no means necessarily at) the speed of half-synchronism.

---

#### PART II—ANALYTICAL.

*By Alfred Hay, D. Sc., M. I. E. E.*

The experimental results described in Part I of the present paper—especially the peculiar shape of the curves in the neighbourhood of half-synchronism—are by no means easy to account for. The following is a complete analytical investigation of the problem by a method which does not appear to have been previously used in connection with alternating current problems.

---

\* See Discussion on Fechheimer's Paper, *loc. cit.*

Owing to the extreme complexity of the problem, it becomes necessary to make the following simplifying assumptions :—

(1) We shall suppose that the armature winding of the machine is so arranged that each phase when traversed by a current gives rise to a simple sine distribution of magnetic flux in space.

(2) We shall neglect the effect of variations in the permeability.

(3) We shall assume that the effect due to eddy-currents in the solid portions of the magnetic circuit may be regarded as equivalent to that of a simple closed single-phase secondary circuit. This equivalent secondary may be conveniently referred to as the “secondary” simply. The field winding forms a tertiary circuit which may be either open or closed. We shall suppose that it is kept open.

(4) The time-variations of certain of the quantities concerned will be supposed to follow the sine law.

It is obvious that during the rotation of the machine the mutual inductance of the secondary with any one phase of the armature winding will undergo periodic fluctuations, and from supposition (1) it follows—as can easily be shown—that such fluctuations will obey the sine law if the speed of rotation is constant. Let  $M_o$  denote the maximum value of the mutual inductance of the secondary and a phase of the armature winding. Then if  $m_a$ ,  $m_b$ , and  $m_c$  denote the instantaneous mutual inductances of the three phases and the secondary at time  $t$ , we may write, since the space displacement of the three oscillating magnetic flux waves due to the armature current is 120 electrical degrees,

$$\begin{aligned}
 m_a &= M_o \sin [(1-s) \omega t + a] \\
 m_b &= M_o \sin \left[ (1-s) \omega t + a + \frac{2\pi}{3} \right] \\
 m_c &= M_o \sin \left[ (1-s) \omega t + a + \frac{4\pi}{3} \right],
 \end{aligned}$$

where  $\omega = 2\pi \times$  frequency of armature current, and  $s =$  slip of rotor ( $= \frac{\text{synchronous speed} - \text{rotor speed}}{\text{synchronous speed}}$ ).

Let the currents in the three armature phases be represented by

$$\begin{aligned}i_a &= I_m \sin \omega t. \\i_b &= I_m \sin \left( \omega t + \frac{2\pi}{3} \right). \\i_c &= I_m \sin \left( \omega t + \frac{4\pi}{3} \right)\end{aligned}$$

If we provisionally assume that the secondary circuit which is supposed to be the equivalent of the solid portions of the magnetic circuit is open, so that it is incapable of reacting on the primary or armature circuits, then in order to maintain the currents  $i_a$ ,  $i_b$  and  $i_c$  in the three phases of the armature we must provide impressed e. m. f. s. which are given by

$$\begin{aligned}e_a &= z_1 I_m \sin (\omega t + \theta_1) \\e_b &= z_1 I_m \sin \left( \omega t + \frac{2\pi}{3} + \theta_1 \right) \\e_c &= z_1 I_m \sin \left( \omega t + \frac{4\pi}{3} + \theta_1 \right)\end{aligned}$$

In the above expressions,  $z_1$  denotes the equivalent impedance of each phase when the three windings are supplied with currents differing  $120^\circ$  in phase. If  $r_1$  = resistance of each phase, and  $L_1$  = true self-inductance of each phase (*i. e.*, flux linkage with phase when unit current is flowing through it and when remaining two phases are devoid of current), then

$$z_1 = \sqrt{r_1^2 + \left( \frac{3}{2} \omega L_1 \right)^2}$$

The fact that the equivalent reactance of a phase is  $\frac{3}{2}$  times its true reactance is due to mutual inductance between phases, and is a consequence of the assumption that the flux distribution in space due to any one phase follows the sine law.\*

The angle  $\theta_1$  in the above expressions is such that

$$\tan \theta_1 = \frac{\frac{3}{2} \omega L_1}{r_1}$$

The total instantaneous flux linked with the secondary due to the armature currents  $i_a$ ,  $i_b$ , and  $i_c$  is

$$F_2 = m_a i_a + m_b i_b + m_c i_c = \frac{3}{2} M_o I_m \cos (s\omega t - a)$$

This flux gives rise to an e. m. f. in the secondary of amount  $e_2 = -\frac{dF_2}{dt} = \frac{3}{2} s\omega M_o I_m \sin (s\omega t - a)$ .

\* Hay, *Alternating Currents*, p. 47 (4th edition).



We shall now assume that the secondary is closed, and that the e. m. f.  $e_2$  is allowed to produce a current in it.

Let  $r_2, L_2$  be the resistance and self-inductance respectively of the secondary. Its impedance is then

$$z_2 = \sqrt{r_2^2 + (s\omega L_2)^2}$$

and the e. m. f.  $e_2$  gives rise to a secondary current

$$i_2 = \frac{3}{2z_2} s\omega M_o I_m \sin (s\omega t - \alpha - \theta_2), \quad \text{where } \tan \theta_2 = \frac{s\omega L_2}{r_2}.$$

For the sake of simplicity, we shall put  $k_2 = \frac{\frac{3}{2} s\omega M_o}{z_2}$

so that we may write  $i_2 = k_2 I_m \sin (s\omega t - \alpha - \theta_2)$

The secondary current reacts on the inducing primary or armature circuits, and gives rise to magnetic fluxes linked with them. The flux linkage with the first phase, whose instantaneous mutual inductance with the secondary is  $m_a$ , is given by  $m_a i_2$ , and the e. m. f. to which this flux gives rise is

$$\begin{aligned} -\frac{d}{dt}(m_a i_2) &= -\frac{d}{dt} \left\{ M_o \sin [(1-s)\omega t + \alpha] \cdot k_2 I_m \sin (s\omega t - \alpha - \theta_2) \right\} \\ &= \left(\frac{1}{2} - s\right) \omega M_o k_2 I_m \sin [(1-2s)\omega t + 2\alpha + \theta_2] - \frac{1}{2} \omega M_o k_2 I_m \sin (\omega t - \theta_2) \end{aligned}$$

Similar expressions (with suitable changes of time-phase) hold good for the remaining two phases.

It will be noticed that each of these e. m. f. s. consists of two components of different frequency. If we wished to maintain the original currents  $i_a, i_b$  and  $i_c$  unaltered, then in addition to the original impressed e. m. f. s.  $e_a, e_b$ , and  $e_c$  we should have to provide e. m. f. s. equal and opposite in phase to those induced in the primaries by the secondary current  $i_2$ . Now since these latter e. m. f. s. consist of two components, one [such as  $-\frac{1}{2} \omega M_o k_2 I_m \sin (\omega t - \theta_2)$  in the first phase of the primary] of fundamental frequency, and the other [such as  $(\frac{1}{2} - s) \omega M_o k_2 I_m \sin [(1-s)\omega t + 2\alpha + \theta_2]$  in the first phase] of a frequency which is a function of the slip, the source

of impressed e. m. f. would have to be capable of a continuous variation of wave-shape in order that the currents  $i_a$ ,  $i_b$  and  $i_c$  might remain unaltered. It is needless to point out that such special continuous variation of wave-shape could not be secured in practice. We shall therefore make an assumption which is much more likely to conform to actual conditions. We shall suppose that the source of impressed e. m. f. continues to supply a pure sine wave, but that the excitation of this source is varied so that it not only provides the original e. m. f. s.  $e_a$ ,  $e_b$  and  $e_c$ , but, in addition, any other sine-wave components of *fundamental frequency* which may be necessary to balance fundamental frequency e. m. f. s. [such as the e. m. f.  $-\frac{1}{2} \omega M_o k_2 I_m \sin(\omega t - \theta_2)$  in the first phase] induced in the primaries by the secondary. The remaining components in the induced e. m. f. s., whose frequency differs from the fundamental, and which are not balanced by corresponding components in the impressed e. m. f. waves, give rise to additional primary currents whose magnitude we proceed to determine.

For the sake of simplicity, we shall assume the impedance of the source of impressed e. m. f. to be negligible in comparison with the impedance of the primaries of the machine under consideration, so that the total impedance of the circuits on which the induced e. m. f. s. of frequency other than the fundamental act will be represented by the impedance of the primaries. The equivalent reactance of each phase of the primary corresponding to e. m. f. s. such as  $(\frac{1}{2}-s) \omega M_o k_2 I_m \sin[(1-2s)\omega t + 2\alpha + \theta_2]$  in the first phase, is  $\frac{3}{2}(1-2s)\omega L_1$ . Hence the corresponding current in the first phase is given by

$$i'_a = \frac{(\frac{1}{2}-s) \omega M_o k_2 I_m}{\sqrt{r_1^2 + [\frac{1}{2}(1-2s)\omega L_1]^2}} \sin[(1-2s)\omega t + 2\alpha + \theta_2 - \theta_3].$$

If for the sake of simplicity we put  $k_1 = \frac{(\frac{1}{2}-s) \omega M_o}{z_3}$ ,

$$\text{then } i'_a = k_1 k_2 I_m \sin[(1-2s)\omega t + 2\alpha + \theta_2 - \theta_3]$$

Similar expressions hold good, with suitable changes of time-phase, for the corresponding currents in the remaining two phases.

Before proceeding further, it will be convenient to collect all the results so far obtained.

In the first phase of the primary, we have the following components of impressed e. m. f. :--

$$e_a = z_1 I_m \sin(\omega t + \theta_1) \dots \dots \dots (1)$$

$$\text{and } e'_a = \frac{1}{2} \omega M_0 k_2 I_m \sin(\omega t - \theta_2) \dots \dots (2)$$

$$\text{where } z_1 = \sqrt{r_1^2 + \left(\frac{3}{2} \omega L_1\right)^2} \dots \dots (3)$$

$$\tan \theta_1 = \frac{\frac{3}{2} \omega L_1}{r_1} \dots \dots (4)$$

$$k_2 = \frac{\frac{3}{2} \omega M_0}{z_2} \dots \dots (5)$$

$$z_2 = \sqrt{r_2^2 + (s \omega L_2)^2} \dots \dots (6)$$

$$\tan \theta_2 = \frac{s \omega L_2}{r_2} \dots \dots (7)$$

Next, in the first phase of the primary we have the current components

$$i_a = I_m \sin \omega t \dots \dots \dots (8)$$

$$\text{and } i'_a = k_1 k_2 I_m \sin[(1 - 2s)\omega t + 2\alpha + \theta_2 - \theta_3] \dots (9)$$

$$\text{where } k_1 = \frac{(\frac{1}{2} - s) \omega M_0}{z_3} \dots \dots (10)$$

$$z_3 = \sqrt{r_1^2 + \left[\frac{3}{2}(1 - 2s) \omega L_1\right]^2} \dots \dots (11)$$

$$\tan \theta_3 = \frac{\frac{3}{2}(1 - 2s) \omega L_1}{r_1} \dots \dots (12)$$

Again, considering the secondary, we have in it the induced e. m. f.

$$e_2 = \frac{3}{2} s \omega M_0 I_m \sin (s \omega t - \alpha) \dots \dots (13)$$

which gives rise to the secondary current

$$i_2 = k_2 I_m \sin (s \omega t - \alpha - \theta_2) \dots \dots (14)$$

We may now proceed with our investigation.

In addition to the e. m. f.  $e_2$  in the secondary, which is due to the original currents  $i_a$ ,  $i_b$  and  $i_c$  in the primaries, and which produces the current  $i_2$ , we now have another e. m. f., due

to currents of the type  $i'_a$  in the primaries. This second e. m. f., in the case of  $e_2$ , may be shown to be

$$e'_2 = \frac{3}{2} s \omega M_o k_1 k_2 I_m \sin (s \omega t - \alpha - \theta_2 + \theta_3) \quad \dots \quad (15)$$

If we were to provide an e. m. f. in the secondary equal and opposite to  $e'_2$ , this latter e. m. f. would be neutralised, and the only currents in the primaries and the secondary would be those already considered and given by (8), (9), and (14).

Since, however, no such neutralisation actually takes place, the e. m. f.  $e'_2$  is free to act, and gives rise to a current in the secondary

$$i'_2 = k_1 k_2^2 I_m \sin (s \omega t - \alpha - 2 \theta_2 + \theta_3) \quad \dots \quad (16)$$

This current, in turn, reacts on the primary, and, proceeding as before, we can show that it induces in the first phase of the primary an e. m. f. given by

$$\left(\frac{1}{2} - s\right) \omega M_o k_1 k_2^2 I_m \sin [(1 - 2s) \omega t + 2\alpha + 2\theta_2 - \theta_3] - \frac{1}{2} \omega M_o k_1 k_2^2 I_m \times \sin (\omega t - 2\theta_2 + \theta_3).$$

This e. m. f. is seen to consist of two terms of different frequency. We shall assume, as before, that the term of fundamental frequency is balanced by an equal and opposite component

$$e''_a = \frac{1}{2} \omega M_o k_1 k_2^2 I_m \sin (\omega t - 2\theta_2 + \theta_3) \quad \dots \quad (17)$$

in the impressed e. m. f. wave of the primary, while the other term, being unbalanced, gives rise to a current in the first phase of the primary

$$i''_a = k_1^2 k_2^2 I_m \sin [(1 - 2s) \omega t + 2\alpha + 2\theta_2 - 2\theta_3] \quad \dots \quad (18)$$

Again, the current  $i''_1$ , like  $i_1$  and  $i'_1$ , induces an e. m. f. in the secondary, given by

$$e''_2 = \frac{3}{2} s \omega M_o k_1^2 k_2^2 I_m \sin (s \omega t - \alpha - 2\theta_2 + 2\theta_3) \quad \dots \quad (19)$$

The e. m. f.  $e''_2$  gives rise to a secondary current

$$i''_2 = k_1^2 k_2^3 I_m \sin (s \omega t - \alpha - 3\theta_2 + 2\theta_3) \quad \dots \quad (20)$$

The current  $i''_2$ , in its turn, reacts on the primary, inducing in the first phase an e. m. f.

$$\left(\frac{1}{2} - s\right) \omega M_o k_1^2 k_2^3 I_m \sin [(1 - 2s) \omega t + 2\alpha + 3\theta_2 - 2\theta_3] - \frac{1}{2} \omega M_o k_1^2 k_2^3 I_m \sin (\omega t - 3\theta_2 + 2\theta_3),$$

the fundamental frequency component of which we shall assume,



as before, to be balanced by a component in the impressed e. m. f equal to

$$e''_a = \frac{1}{2} \omega M_o k_1^2 k_2^3 I_m \sin (\omega t - 3 \theta_2 + 2 \theta_3) \quad \dots (21)$$

while the other component is left free to produce in the first phase of the primary a current

$$i''_a k_1^3 k_2^3 I_m \sin [(1-2s)\omega t + 2a + 3 \theta_2 - 3\theta_3] \quad \dots (22)$$

Proceeding in this way, we ultimately obtain, for each of the quantities under consideration -- primary impressed e. m. f., primary current, secondary induced e. m. f., and secondary current an infinite series of terms.

For the sake of simplicity, we shall put

$$k = k_1 k_2 \quad \dots (23)$$

$$\text{and } \theta = \theta_2 - \theta_3 \quad \dots (24)$$

Considering first the primary impressed e. m. f. in the first phase, we see from (1), (2), (17) and (21), that this is given by

$$z_1 I_m \sin(\omega t + \theta_1) + \frac{1}{2} \omega M_o k_2 I_m [\sin(\omega t - \theta_2) + k \sin(\omega t - \theta_2 - \theta) + k^2 \sin(\omega t - \theta_2 - 2\theta) + k^3 \sin(\omega t - \theta_2 - 3\theta) + \dots] \quad \dots (25)$$

Similar expressions, with suitable time-phase differences, hold good for the impressed e. m. f. s. in the other two phases.

Taking next the primary current in the first phase, and using (8), (9), (18) and (22), we find that this current is given by the infinite series

$$I_m \sin \omega t + k I_m \{ \sin [(1-2s)\omega t + 2a + \theta] + k \sin [(1-2s)\omega t + 2a + 2\theta] + k^2 \sin [(1-2s)\omega t + 2a + 3\theta] + \dots \} \quad \dots (26)$$

Similarly, using (13), (15) and (19), we find for the secondary induced e. m. f.

$$\frac{3}{2} s \omega M_o I_m [\sin(s\omega t - a) + k \sin(s\omega t - a - \theta) + k^2 \sin(s\omega t - a - 2\theta) + \dots] \quad \dots (27)$$

Lastly, using (14), (16) and (20), we obtain the secondary current

$$k_2 I_m [\sin(s\omega t - a - \theta_2) + k \sin(s\omega t - \theta_2 - \theta) + k^2 \sin(s\omega t - a - \theta_2 - 2\theta) + \dots] \quad \dots (28)$$

Each of the four expressions (25), (26) (27) and (28) involves an infinite series of the type

$$\Sigma = \sin \phi + k \sin (\phi \pm \theta) + k^2 \sin (\phi \pm 2\theta) + k^3 \sin (\phi \pm 3\theta) + \dots$$

This series may be summed as follows.

$$\begin{aligned} \text{Putting } \sin \phi &= \frac{1}{2j} (e^{j\phi} - e^{-j\phi}), \text{ and } \sin (\phi \pm n\theta) \\ &= \frac{1}{2j} [e^{j(\phi \pm n\theta)} - e^{-j(\phi \pm n\theta)}], \end{aligned}$$

where  $j^2 = -1$ , we may write

$$\begin{aligned} \Sigma &= \frac{1}{2j} \left\{ e^{j\phi} (1 + ke^{\pm j\theta} + k^2 e^{\pm 2j\theta} + k^3 e^{\pm 3j\theta} + \dots) \right. \\ &\quad \left. - e^{-j\phi} (1 + ke^{\mp j\theta} + k^2 e^{\mp 2j\theta} + \dots) \right\} \\ &= \frac{1}{2j} \left( \frac{e^{j\phi}}{1 - ke^{\pm j\theta}} - \frac{e^{-j\phi}}{1 - ke^{\mp j\theta}} \right), \end{aligned}$$

which, after a number of transformations, may be reduced to the simple form

$$\Sigma = \frac{\sin \phi - k \sin (\phi \mp \theta)}{(1 - k \cos \theta)^2 + (k \sin \theta)^2}$$

If we put

$$a = \sqrt{(1 - k \cos \theta)^2 + (k \sin \theta)^2} \quad \dots (29)$$

$$\text{and } \tan \beta = \frac{k \sin \theta}{1 - k \cos \theta} \quad \dots (30)$$

then, after a further transformation, we may write

$$\Sigma = \frac{1}{a} \sin (\phi \pm \beta) \quad \dots (31)$$

Primary P. D. Applying this result to (25), we find for the primary impressed e. m. f. in the first phase

$$z_1 I_m \sin (\omega t + \theta_1) + \frac{\frac{1}{2} \omega M_o k_2 I_m}{a} \sin (\omega t - \theta_2 - \beta).$$

This may be thrown into the form

$$E \sin (\omega t + \psi) \quad \dots (32)$$

where

$$E = I_m \left\{ \left[ r_1 + \frac{\frac{1}{2} \omega M_o k_2}{a} \cos (\theta_2 + \beta) \right]^2 + \left[ \frac{\frac{3}{2} \omega L_1}{a} - \frac{\frac{1}{2} \omega M_o k_2}{a} \sin (\theta_2 + \beta) \right]^2 \right\}^{\frac{1}{2}} \dots (33)$$

and

$$\tan \psi = \frac{\frac{\frac{3}{2} \omega L_1}{a} - \frac{\frac{1}{2} \omega M_o k_2}{a} \sin (\theta_2 + \beta)}{r_1 + \frac{\frac{1}{2} \omega M_o k_2}{a} \cos (\theta_2 + \beta)} \dots (34)$$

**Primary Current.** Similarly, using (31) and (26), we obtain for the primary current in the first phase

$$I_m \left\{ \sin \omega t + \frac{k}{a} \sin [(1-2s) \omega t + 2\alpha + \theta + \beta] \right\} \dots (35)$$

It will be noticed that, with a pure sine wave of impressed e. m. f., the primary current wave is a distorted one.

**Secondary Current.** Proceeding in a similar manner with (27) and (28), we obtain the following expressions for the secondary induced e. m. f. and secondary current :—

$$\text{Secondary induced e. m. f.} = I_m \frac{\frac{3}{2} s \omega M_o}{a} \sin (s \omega t - \alpha - \beta) \dots (36)$$

$$\text{Secondary current} = I_m \frac{k_2}{a} \sin (s \omega t - \alpha - \theta_2 - \beta) \dots (37)$$

Both the above waves are pure sine waves.

**Tertiary E. M. F.** We next proceed to determine the e. m. f. induced in the open field winding, which we may term the tertiary circuit. This e. m. f. is the resultant of the two e. m. f.s. induced by the primary and secondary currents. Let  $m'_a$ ,  $m'_b$  and  $m'_c$ , denote the instantaneous mutual inductances between the tertiary and the three phases of the primary. Then we may write

$$\begin{aligned} m'_a &= M_1 \sin [(1-s) \omega t + \alpha] \\ m'_b &= M_1 \sin [(1-s) \omega t + \alpha + \frac{2\pi}{3}] \\ m'_c &= M_1 \left[ \sin (1-s) \omega t + \alpha + \frac{4\pi}{3} \right] \end{aligned}$$

The total instantaneous flux linkage with the tertiary due to the joint action of the currents in the three phase of the primary is

$$\begin{aligned} & M_1 I_m \sin [(1-s)\omega t + a] \left\{ \sin \omega t + \frac{k}{a} \sin [(1-2s)\omega t + 2a + \beta] \right\} \\ & + M_1 I_m \sin [(1-s)\omega t + a + \frac{2\pi}{3}] \left\{ \sin (\omega t + \frac{2\pi}{3}) \right. \\ & \quad \left. + \frac{k}{a} \sin [(1-2s)\omega t + \frac{2\pi}{3} + 2a + \beta] \right\} \\ & + M_1 I_m \sin [(1-s)\omega t + a + \frac{4\pi}{3}] \left\{ \sin (\omega t + \frac{4\pi}{3}) \right. \\ & \quad \left. + \frac{k}{a} \sin [(1-2s)\omega t + \frac{4\pi}{3} + 2a + \beta] \right\} \end{aligned}$$

This, after simple transformations, is reducible to the form

$$\frac{3}{2} M_1 I_m \cos (s\omega t - a) + \frac{3}{2} \frac{k}{a} M_1 I_m \cos (s\omega t - a - \beta),$$

and the tertiary e. m. f. due to this flux is

$$\frac{3}{2} s\omega M_1 I_m \sin (s\omega t - a) + \frac{3}{2} s\omega M_1 I_m \frac{k}{a} \sin (s\omega t - a - \beta)$$

Next, if we denote by  $M_2$  the mutual inductance between the tertiary and the secondary, the flux linkage with the tertiary due to the current in the secondary is

$$M_2 I_m \frac{k_2}{a} \sin (s\omega t - a - \theta_2 - \beta),$$

and the tertiary e. m. f. due to it is

$$-s\omega M_2 I_m \sin \frac{k_2}{a} \cos (s\omega t - a - \theta_2 - \beta).$$

Thus the total tertiary e. m. f. is given by

$$\begin{aligned} s\omega I_m \left\{ \frac{3}{2} M_1 \sin (s\omega t - a) + \frac{3}{2} M_1 \frac{k}{a} \sin (s\omega t - a - \beta) \right. \\ \left. - M_2 \frac{k_2}{a} \cos (s\omega t - a - \theta_2 - \beta) \right\} \end{aligned}$$

This may be exhibited in the form

$$e_3 = E_3 \sin (s\omega t - a - \gamma) \quad \dots (38),$$



where

$$E_3 = I_m s \omega \left\{ \left[ \frac{3}{2} M_1 \left( 1 + \frac{k}{a} \cos \beta \right) - M_2 \frac{k_2}{a} \sin (\theta_2 + \beta) \right]^2 + \left[ \frac{3}{2} M_1 \frac{k}{a} \sin + \beta M_2 \frac{k_2}{a} \cos (\theta_2 + \beta) \right]^2 \right\}^{\frac{1}{2}} \dots (39)$$

and

$$\tan \gamma = \frac{\frac{1}{a} \left[ \frac{3}{2} k M_1 \sin \beta + k_2 M_2 \cos (\theta_2 + \beta) \right]}{\frac{3}{2} M_1 \left( 1 + \frac{k}{a} \cos \beta \right) - M_2 \frac{k_2}{a} \sin (\theta_2 + \beta)} \dots (40)$$

**Primary Power.** We shall next consider the power impressed on the primary. Since the variable frequency component in the primary current wave (35) is incapable of contributing to the power, the only effective component is that of fundamental frequency, and this yields an amount of power in the first phase give by

$$\frac{1}{2} E I_m \cos \psi,$$

so that the total primary power in all three phases is

$$\frac{3}{2} E I_m \cos \psi \dots (41)$$

**Power Factor.** The r. m. s. value of the primary current (35) being

$$\frac{I_m}{\sqrt{2}} \left[ 1 + \left( \frac{k}{a} \right)^2 \right]^{\frac{1}{2}}$$

the volt-amperes per phase are given by

$$E I_m \frac{1}{2} \left[ 1 + \left( \frac{k}{a} \right)^2 \right]^{\frac{1}{2}}$$

so that the power factor of the primary is

$$\frac{\cos \psi}{\left[ 1 + \left( \frac{k}{a} \right)^2 \right]^{\frac{1}{2}}} \dots \dots (42)$$

**Mechanical Power.** We shall now consider the total *mechanical power* transmitted to the rotor of the machine. In the preceding investigation, we have supposed the resistance and self-inductance of the equivalent secondary to have been so chosen that the values of the primary currents for given impressed primary e. m. f. s. are identical with those obtaining in the

actual machine. The losses due to hysteresis and eddy-currents are therefore represented by the copper losses in the equivalent secondary. If, then, we subtract the primary and secondary copper losses from the total primary power, the balance gives us the mechanical power available. A consideration of the mechanical power is, it is needless to point out, of very great interest in connection with the self-starting qualities of the machine.

**Torque.** The value of the torque exerted by the rotor is easily determined from the mechanical power by dividing the latter by the angular velocity.

Up to the present, we have supposed the tertiary to be on open circuit. If now we imagine it to be closed, tertiary currents will appear which will react on both primaries and secondary. The same general principle as that already used might be employed for investigating the reactions of the various circuits on each other. But if we are concerned only with the general nature of the results obtained, it is simpler to suppose the secondary and tertiary circuits replaced by a single equivalent secondary. Thus the general law of variation of the tertiary current will be the same as that of the secondary, which we have already investigated.

The method used in the above investigation is, it will be observed, identical in principle with Lord Kelvin's method of electrical images as applied to problems in electrostatics. It may possibly be found to be of great use in connection with certain types of alternating current problems.

The results obtained above have been applied to a particular case which corresponds approximately to the synchronous machine experimented on. The following numerical values (at a frequency of 12.5) have been assumed for the various constants:—

$$\begin{array}{llll} r_1 = \cdot 006 & r_2 = \cdot 004 & \omega M_o = \cdot 043 & \omega M'_1 = 4\cdot 2 \\ \omega L_1 = \cdot 0513 & \omega L_2 = \cdot 046 & I_m = 48\cdot 3 & \omega M_2 = 2\cdot 3 \end{array}$$

By the aid of the formulae established above, values of the primary p. d., primary current, secondary current, tertiary e. m. f., primary power, mechanical power, torque, power factor and phase angle were calculated for various values of  $s$  and a constant value of 48.3 for  $I_m$ . Since all the variables involving  $I_m$  are directly proportional to it, we can immediately find their values for any other value of  $I_m$ . Accordingly, we can find the values corresponding to those values of  $I_m$  for various values of  $s$  which yield a constant value for the primary current. This will

give us the variations of the quantities with  $s$  when the *primary current is maintained constant*. The values so calculated are given in Table I, and some of them are plotted in Fig. 15. Similarly, we may obtain the values of the variables for different values of  $s$  when the values of  $I_m$  are so chosen as to yield a constant value of the primary p. d. We thus obtain the results given in Table II., which corresponds to a *constant primary line P. D.* of 10 volts. and from which the curves of Fig. 16 have been plotted.

The theoretical curves of Figs. 15 and 16 may be compared with the experimental curves given in Part I. It will be noticed that the general shapes of the curves correspond in the two cases, and that the peculiarities of shape are satisfactorily accounted for by theory. The experimental curves, however, do not exhibit such very pronounced peaks and valleys as do the theoretical ones. In this connection it must be remembered that the theoretical curves are based on a number assumptions which are not quite realised in practice. Among others, the assumption has been made that the primary p. d. retains its pure sine wave form, and remains unaffected by the variable frequency component of the primary current. In the actual experiments, the generator was a machine of smaller output than the synchronous motor, and its e. m. f. would certainly suffer distortion.

From a practical point of view, the most interesting result is the reversal of torque which occurs in the neighbourhood of half-synchronism. This effect has been well known for a long time, and the tendency of synchronous machines to "stick at half-synchronism" has frequently been noticed by operators.

When starting up a synchronous machine by applying an alternating voltage to its terminals, the field winding may be left open or closed. If the torque at half-synchronism due to the squirrel-cage winding is less than the peak of the negative torque which the closed field winding would, in accordance with the above investigations, develop in the neighbourhood of half-synchronous speed, then closing the field winding will prevent the machine from running up to synchronous speed, and the final speed reached by the machine will not much exceed that of half-synchronism; if now the field winding be opened, the negative torque due to the field winding will be eliminated, and the machine will be enabled to run up to full synchronism. Thus in certain cases closing the field winding may result in the impossibility of running the machine up to synchronous speed, although the initial starting torque may thereby be increased. It is well to remember in this connection that in the case of a solid field structure the eddy current paths practically form a single-phase winding, and are capable of giving rise to effects similar to those obtained with the single-axis field winding.



TABLE I.

$r_1 = .006$ ;  $\omega L_1 = .0513$ ;  $r_2 = .004$ ;  $\omega L_2 = .046$ ;  $\omega M_o = .043$ ;  $\omega M_1 = 4.2$ ;  $\omega M_2 = 2.3$ ;  
frequency = 12.5.

Primary current maintained constant at 48.3 amperes.

Speed, r. p.m.	Primary Terminal P. D.	Secondary Current	Tertiary E. M. F.	Power supplied to Pr. mary	Power Factor	Phase Angle*	Mechanical Power	Torque, in $10^7$ c.g.s. units
0	2.34	92.2	125	75.9	.388	67°26'	0	
25	2.42	91.8	113	82.3	.405	66°5'	6.6	25.05
50	2.60	91.0	100	92.5	.426	64°47'	17.4	33.2
75	2.78	89.2	86.8	103.7	.446	63°31'	29.8	37.9
100	3.29	84.3	70.6	124	.451	63°11'	53.8	51.4
105	3.47	81.9	65.7	128	.441	63°49'	59.4	54.0
110	3.70	78.5	60.2	131	.422	65°3'	64.1	55.6
115	3.96	73.7	55.8	127	.384	67°24'	63.6	52.8
120	4.16	68.3	59.9	108.5	.312	71°49'	47.8	38.0
122.5	4.18	66.7	67.9	95.9	.275	74°4'	36.1	28.2
125	4.10	66.7	77.7	77.6	.226	76°55'	17.8	13.6
127.5	3.92	68.8	86.1	59.7	.182	79°30'	— 1.2	— 9.3
130	3.67	72.3	91.2	45.7	.149	81°26'	— 17.2	— 12.6
135	3.13	80.0	93.4	35.4	.135	82°14'	— 32.1	— 22.7
140	2.75	85.2	91.2	41.1	.179	79°42'	— 29.9	— 20.4
145	2.56	87.9	88.1	52.0	.243	75°57'	— 20.9	— 13.8
150	2.50	89.3	85.1	63.4	.303	72°22'	— 10.4	— 6.6
162.5	2.61	89.8	77.3	88.1	.408	66°14'	13.8	8.1
175	2.86	88.7	69.2	110	.457	62°48'	36.1	19.7
187.5	3.23	86.4	60.9	131	.483	61°5'	58.8	29.9
200	3.71	82.3	52.4	153	.492	60°31'	83.5	39.9
212.5	4.36	74.9	43.1	173	.474	61°42'	108.3	48.7
220	4.85	67.9	36.7	181	.445	63°33'	120.3	52.2
225	5.21	61.3	31.9	181	.415	65°30'	123.5	52.4
230	5.58	53.0	26.4	174	.373	68°6'	120.8	50.1
235	5.93	42.6	20.3	157	.317	71°31'	108.2	44.0
240	6.33	29.9	13.5	129	.248	75°39'	88.6	33.3
245	6.42	15.5	6.5	89.2	.166	80°26'	46.2	18.0
250	6.46	0	0	42.1	.078	85°32'	0	0
255	6.33	15.3	5.5	— 5.2	— 0.098	90°34'	— 48.1	— 18.0
260	6.08	29.2	9.7	— 45.6	— 0.897	95°9'	— 91.0	— 33.4
275	5.74	41.2	12.9	— 75.6	— 1.157	99°3'	— 134.4	— 44.8
270	5.37	51.0	15.4	— 94.7	— 2.11	102°10'	— 147.1	— 52.0
275	5.00	58.8	17.7	— 105	— 2.51	104°34'	— 161.0	— 55.9
280	4.66	65.0	19.8	— 109	— 2.81	106°18'	— 168.2	— 57.4
287.5	4.20	71.8	22.9	— 108	— 3.08	107°58'	— 171.0	— 56.8
300	3.62	79.2	28.3	— 98.3	— 3.25	108°57'	— 165.4	— 52.6
325	2.82	86.1	39.8	— 71.3	— 3.03	107°37'	— 142.9	— 42.0
350	2.55	89.2	51.5	— 54.7	— 2.56	104°50'	— 128.5	— 35.0
400	2.21	91.4	76.1	— 30.9	— 1.67	99°36'	— 106.4	— 25.4
450	2.09	92.3	100.5	— 17.1	— 0.98	95°38'	— 93.2	— 19.8
500	2.03	92.7	124.8	— 8.4	— 0.496	92°51'	— 84.8	— 16.2

\*Angle of lag of primary current behind primary p. d.



TABLE II.

$r_1 = .006$  ;  $\omega L_1 = .0513$  ;  $r_2 = .004$  ;  $\omega L_2 = .046$  ;  $\omega M_o = .043$  ;  $\omega M_1 = 4.2$  ;  $\omega M_2 = 2.3$  ;  
frequency = 12.5

Primary P. D. maintained constant at 10 volts.

Speed, r. p. m.	Primary current	Secondary current	Tertiary E. M. F.	Power supplied to Primary	Power Factor	Phase angle*	Mechanical Power	Torque, in $10^7$ c.g.s. units
0	206	394	534	1885	.388	67°26'	0	...
25	199	378.5	465	1400	.405	66°5'	112	426
50	186	350.5	386	1370	.426	64°47'	258	493
75	174	321	312	1340	.446	63°31'	386	492
100	147	256	214	1146	.451	63°11'	496	474
105	139	236	189	1060	.441	63°49'	492	448
110	130.4	212	163	952	.422	65°3'	467	405
115	122	186	141	812	.384	67°24'	405	387
120	116	164	144	625	.312	71°49'	276	219
122.5	115.6	160	163	550	.275	74°4'	207	161
125	118	163	190	462	.226	76°55'	106	81
127.5	123	176	220	389	.182	79°30'	-8	-6
130	132	197	249	340	.149	81°26'	-128	-93.9
135	154	255	298	361	.135	82°14'	-327	-231.5
140	176	310	332	545	.179	79°42'	-395	-270
145	189	343	344	793	.243	75°57'	-319	-210
150	193	357	340	1013	.303	72°22'	-166	-106
162.5	185	344	296	1290	.403	66°14'	203	119
175	169	310	241	1335	.457	62°48'	440	240
187.5	150	267.5	189	1250	.483	61°5'	563	237
200	130	222	141	1110	.492	60°31'	608	290
212.5	111	172	99	910.5	.474	61°42'	571	256
220	99.6	140	76	769	.445	63°33'	512	222
225	92.8	118	61	666	.415	65°30'	456	194
230	86.5	95	47.4	559	.373	68°6'	388	161
235	81.4	71.7	34	447	.317	71°31'	307	125
240	77.5	48.1	21.7	332	.248	75°39'	215	85.6
245	75.2	24.1	10.2	217	.166	80°26'	112	43.8
250	74.8	0	0	101	.078	85°32'	0	0
255	76.3	24.1	8.7	-13	-.0098	90°34'	-120	-45
260	79.4	48	16	-123	-.0897	95°9'	-246	-90.4
265	84.1	71.7	22.5	-229	-.157	99°3'	-377	-136
270	89.9	94.9	28.7	-328	-.211	102°10'	-509	-180
275	96.5	118	35.3	-420	-.251	104°34'	-644	-223
280	104	139.5	42.4	-504	-.281	106°18'	-775	-264
287.5	115	171	54.5	-614	-.308	107°58'	-969	-322
300	133.5	219	78.2	-750	-.325	108°57'	-1260	-402
325	171	306	141	-898	-.303	107°37'	-1800	-519
350	189	349	202	-838	-.256	104°50'	-1970	-537
400	218	413	344	-630	-.167	99°36'	-2170	-518
450	231	442	481	-393	-.098	95°38'	-2140	-454
500	238	456	614	-204	-.050	92°51'	-2055	-392

\*Angle of lag of primary current behind primary p. d.

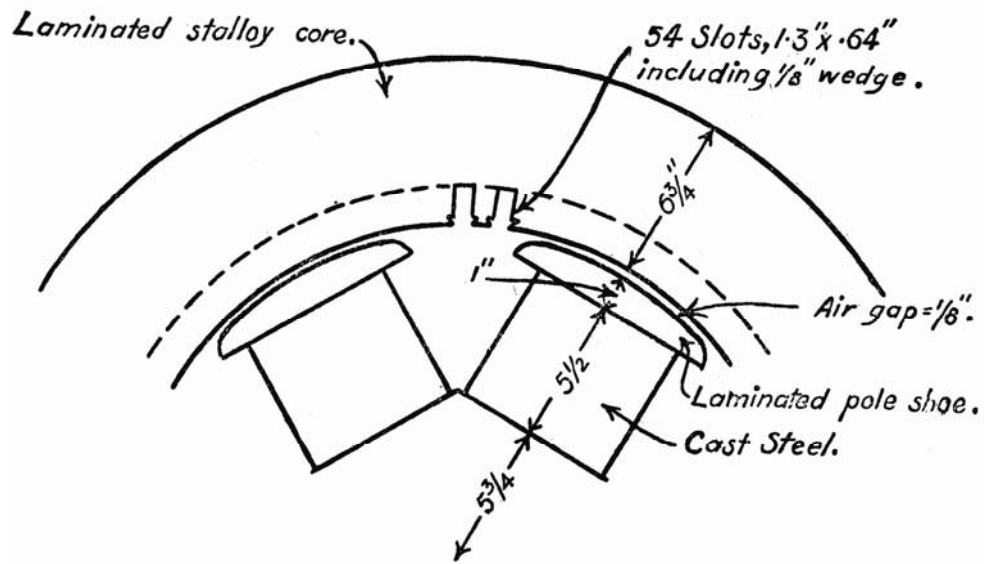

Fig. 1.—Magnetic circuit of synchronous machine.

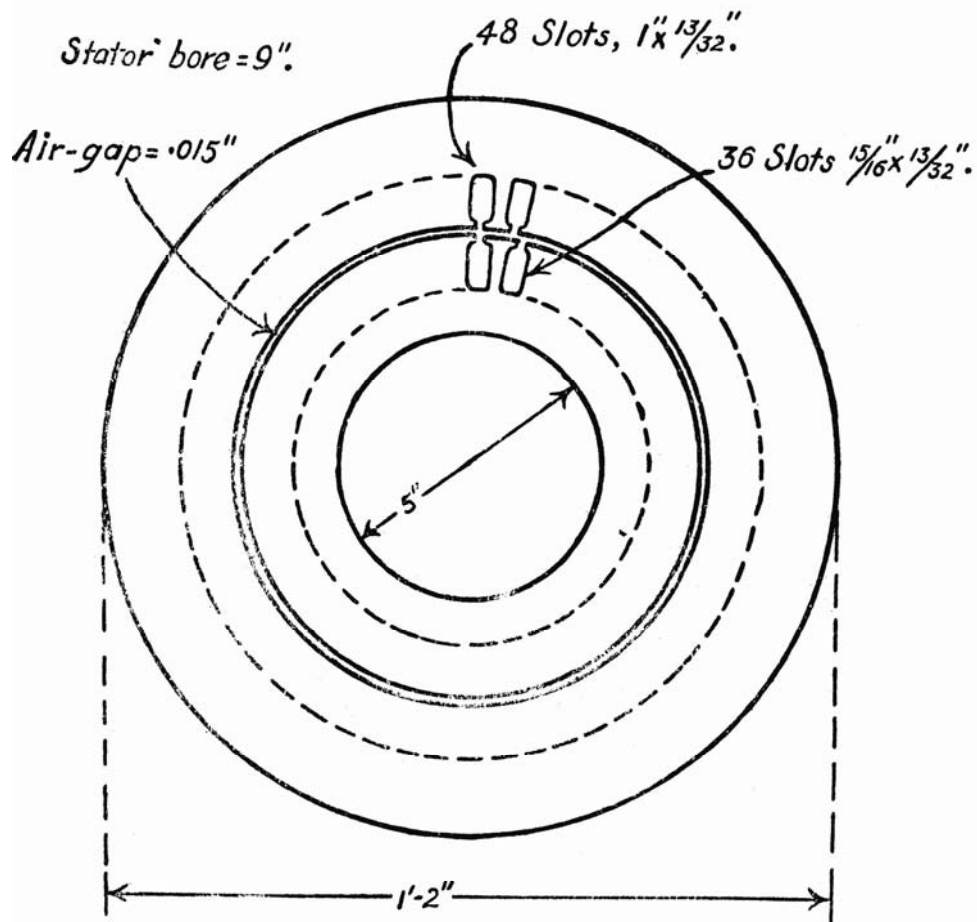

Fig. 2.—Magnetic circuit of induction motor.

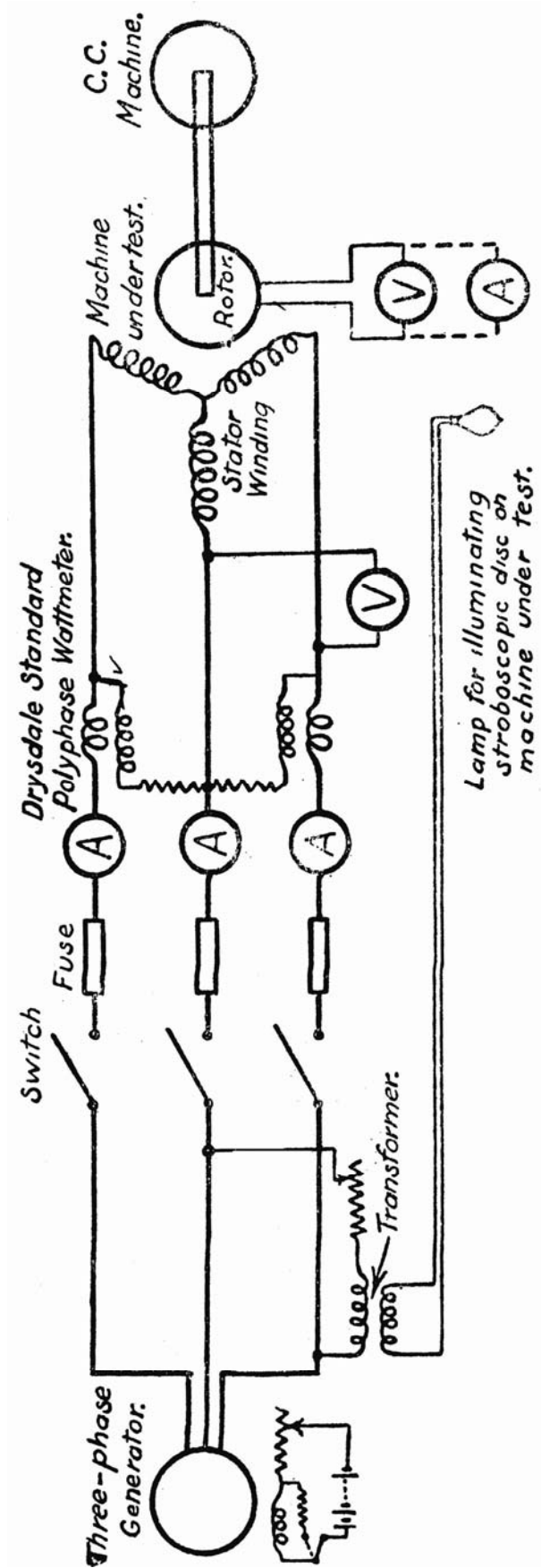

Fig. 3.—Arrangement of connections in synchronous machine tests

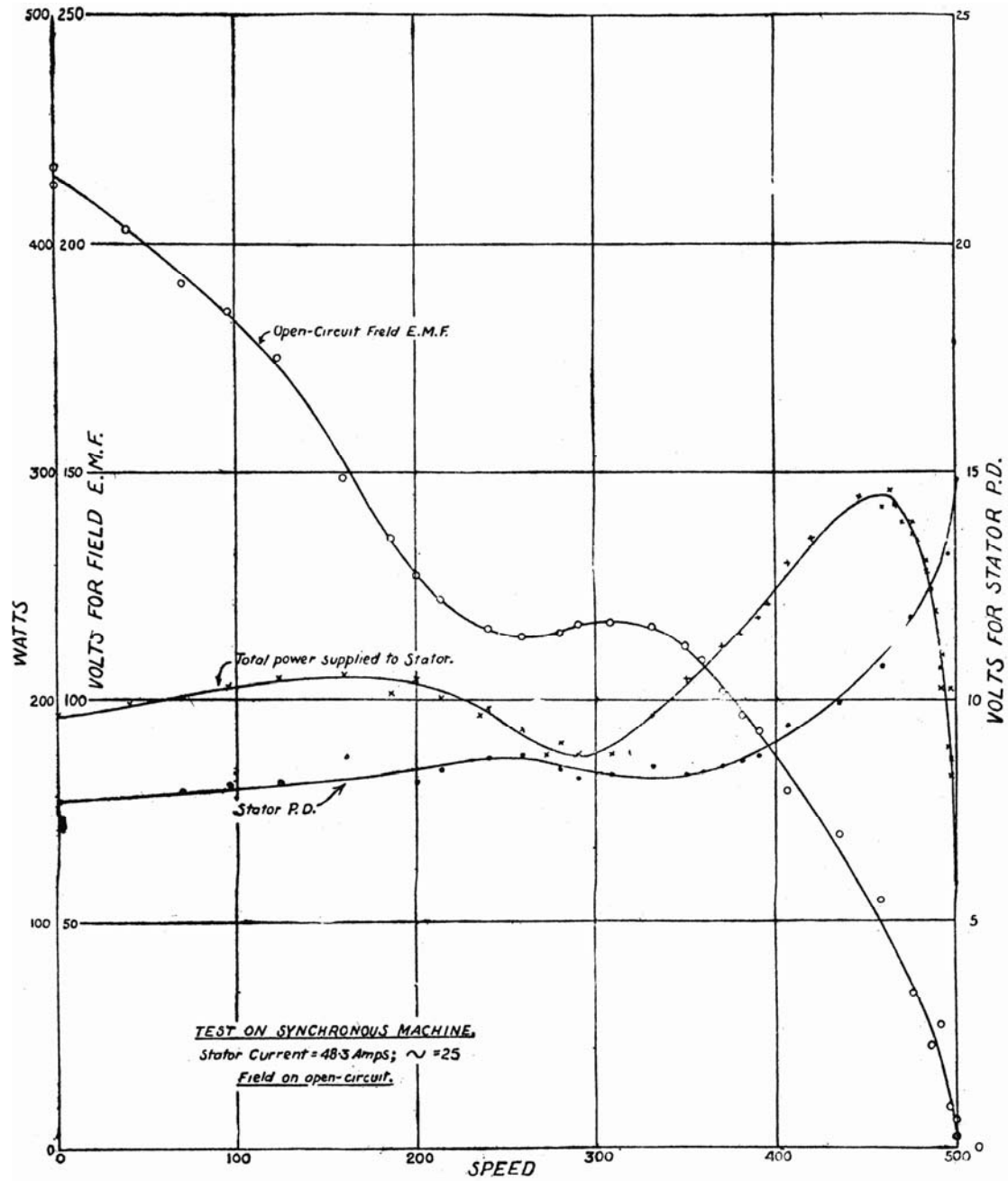

Fig. 4.—Stator p. d., stator power and rotor e. m. f. curves for a constant value of the stator current = 48.3 amps., at a frequency of 25.

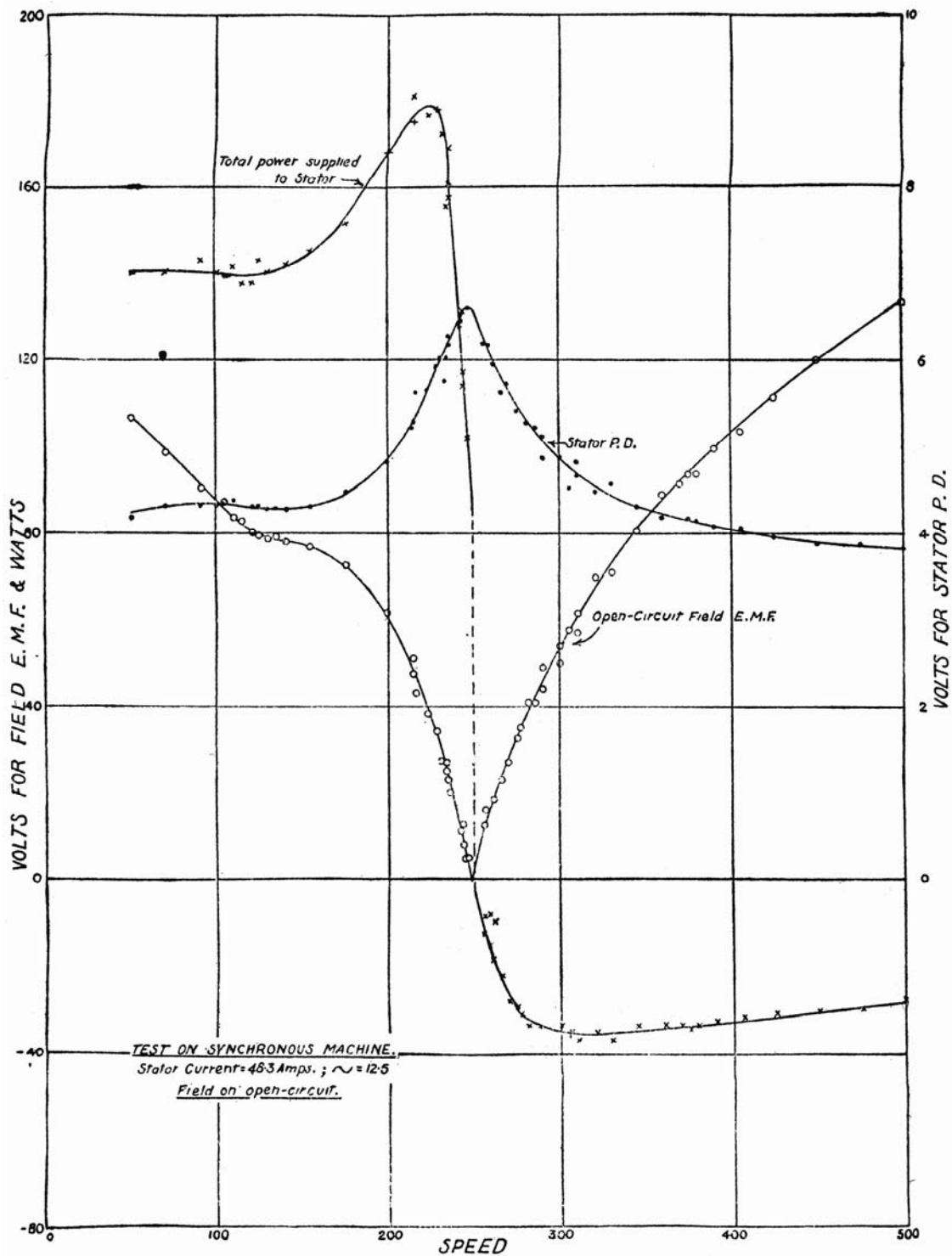

Fig. 5.—Stator p d., stator power and rotor e. m. f. curves corresponding to a constant stator current=48.3 amps., at a frequency of 12.5.



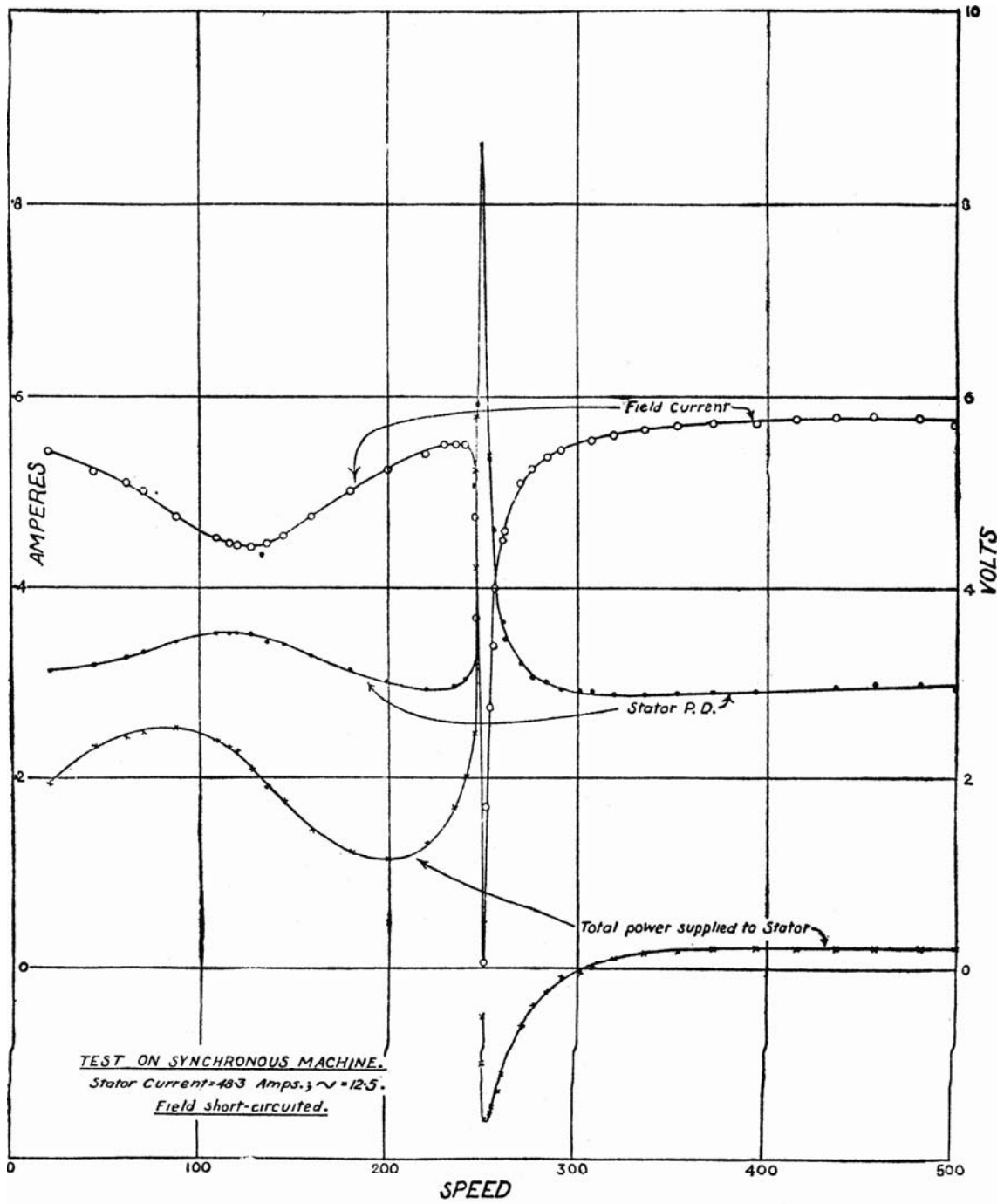

Fig. 6.—Stator p. d., stator power and rotor current curves corresponding to a constant stator current=48.3 amps., at a frequency of 12.5.

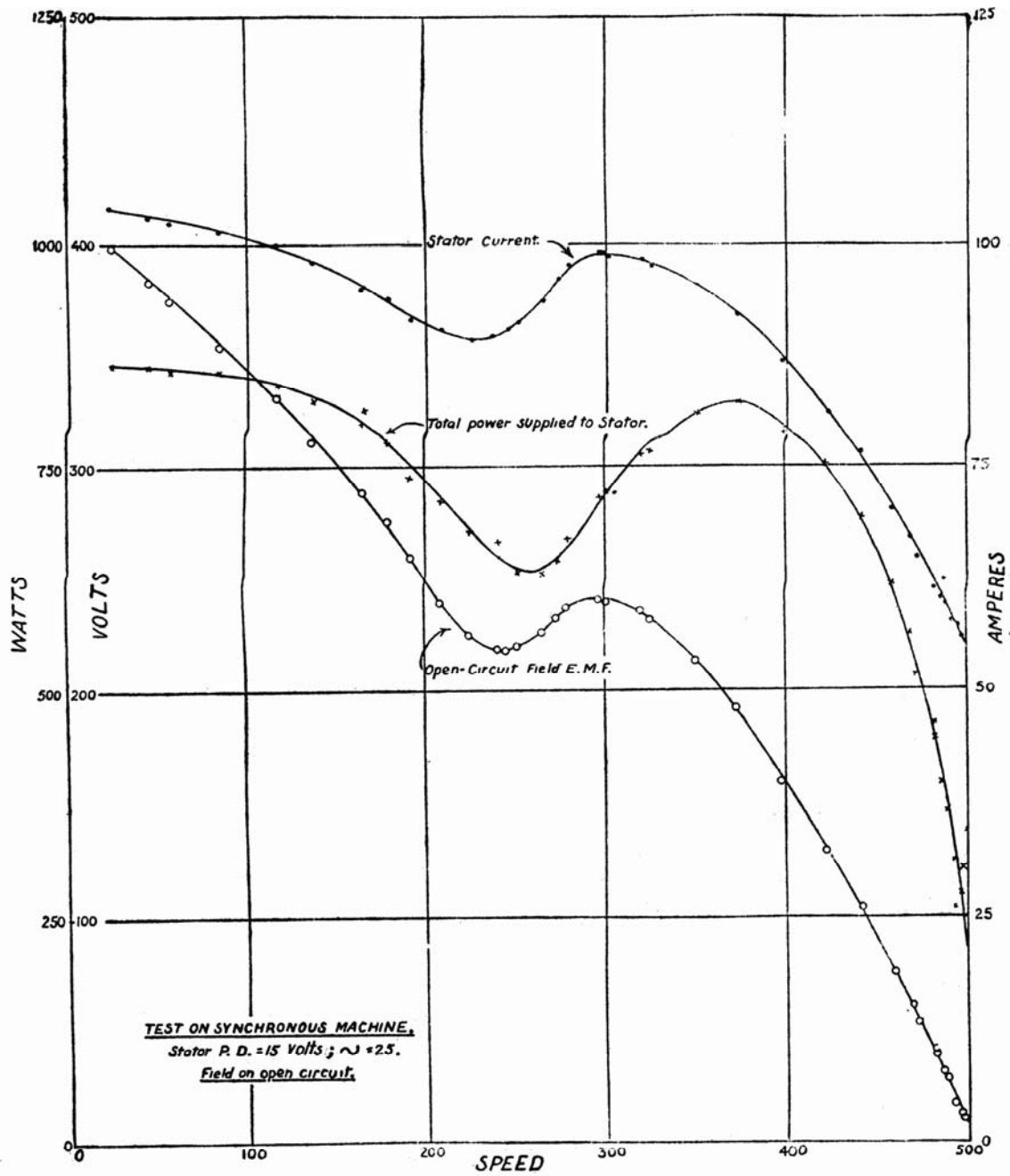

Fig. 7.—Stator current, stator power and rotor e. m. f. curves corresponding to a constant value of the stator p. d.=15 volts, at a frequency of 25.

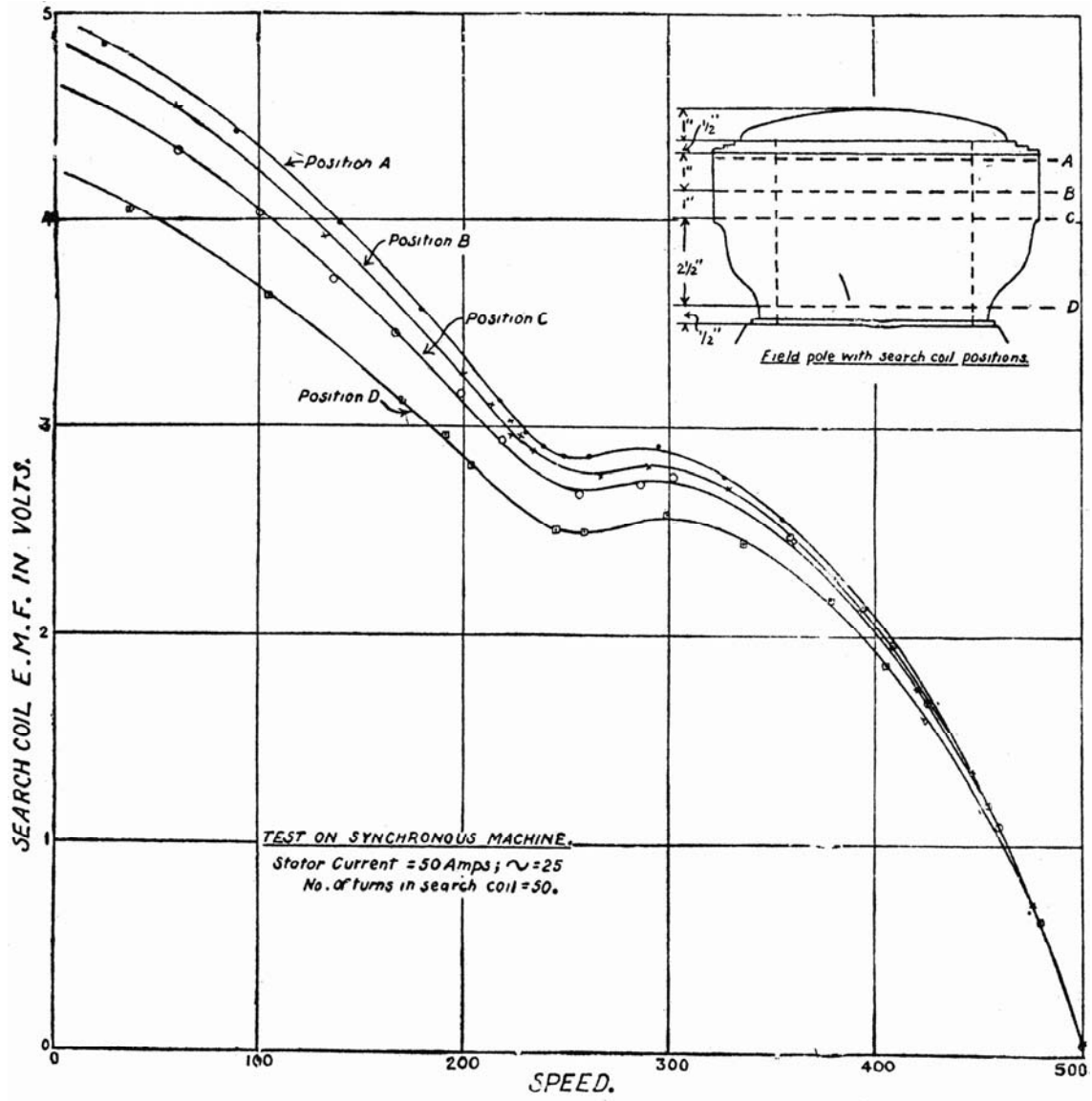

Fig. 8.—Curves showing variations of e. m. f. s induced in search coils.

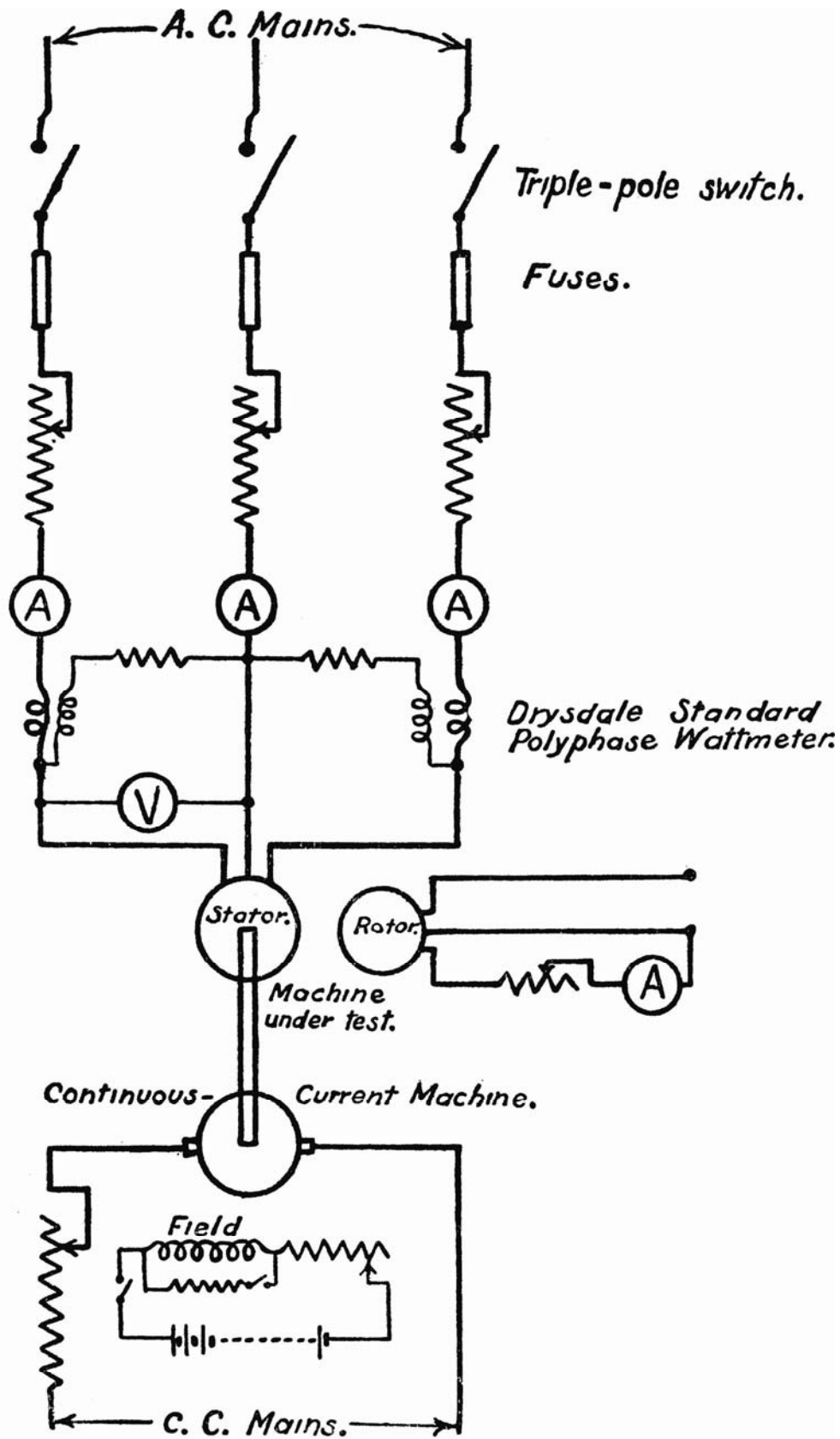

Fig. 9.—Arrangement of connections in induction motor tests.

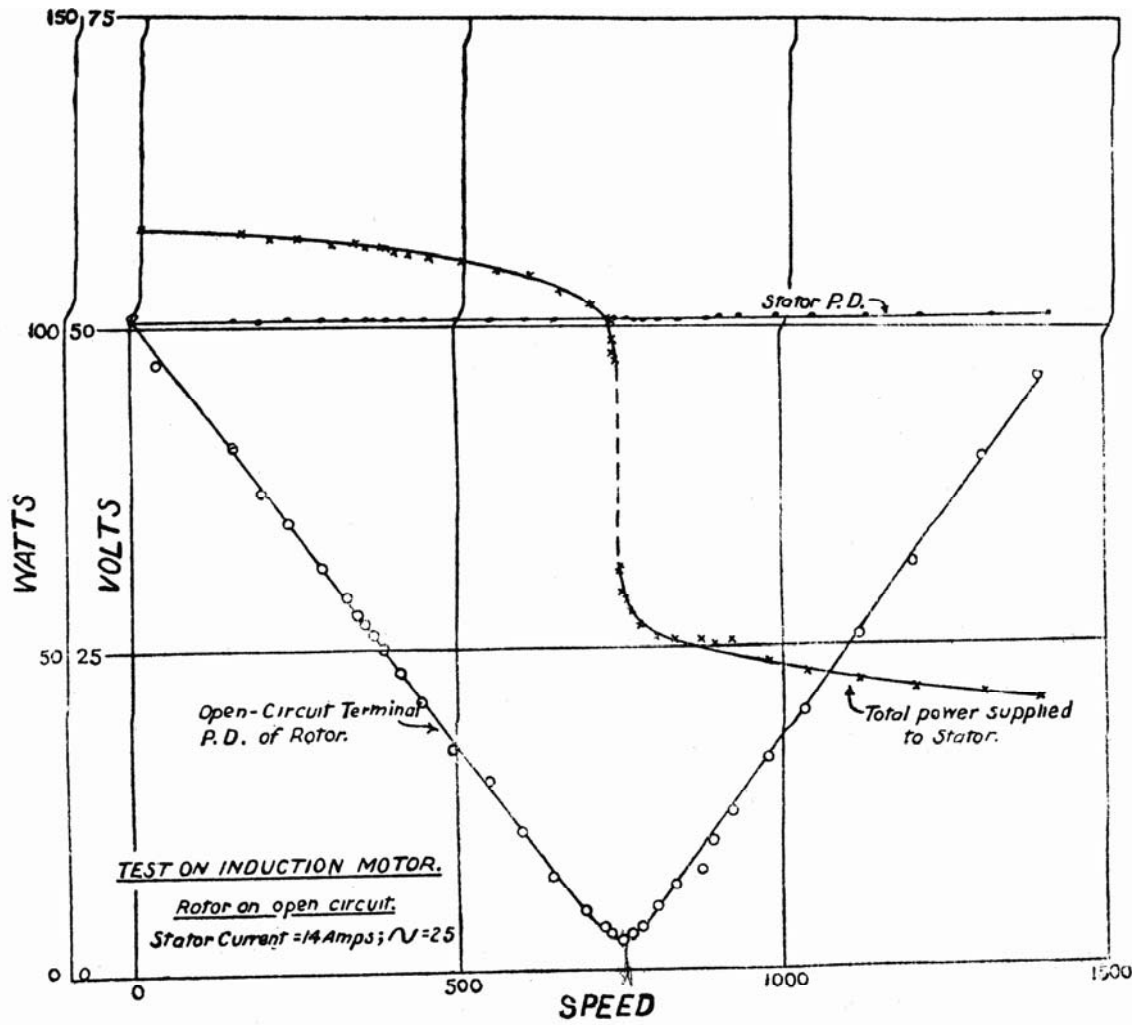

Fig. 10.—Results of induction motor tests with rotor open-circuited.



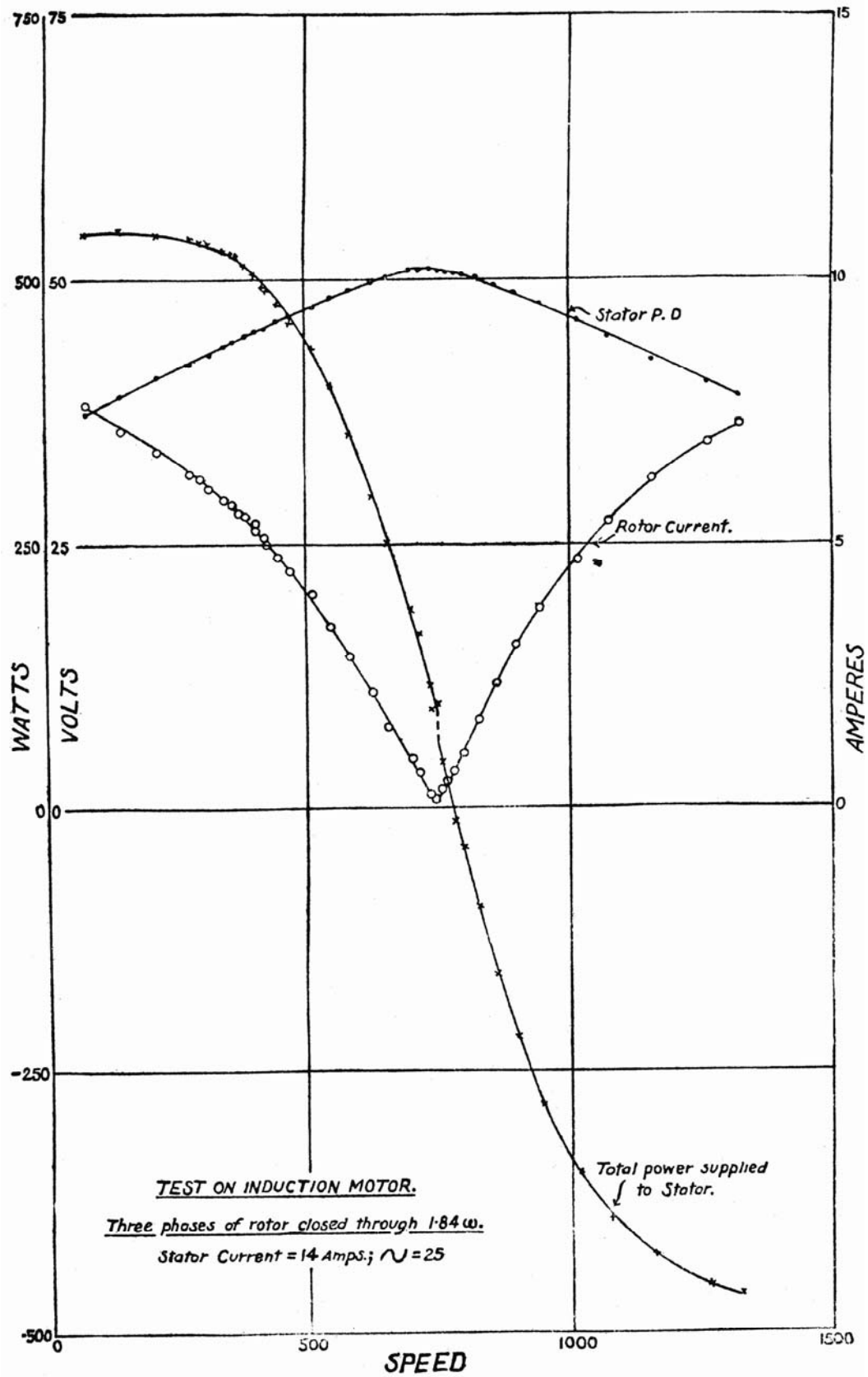

Fig. 11.—Results of induction motor tests with three phases of rotor closed

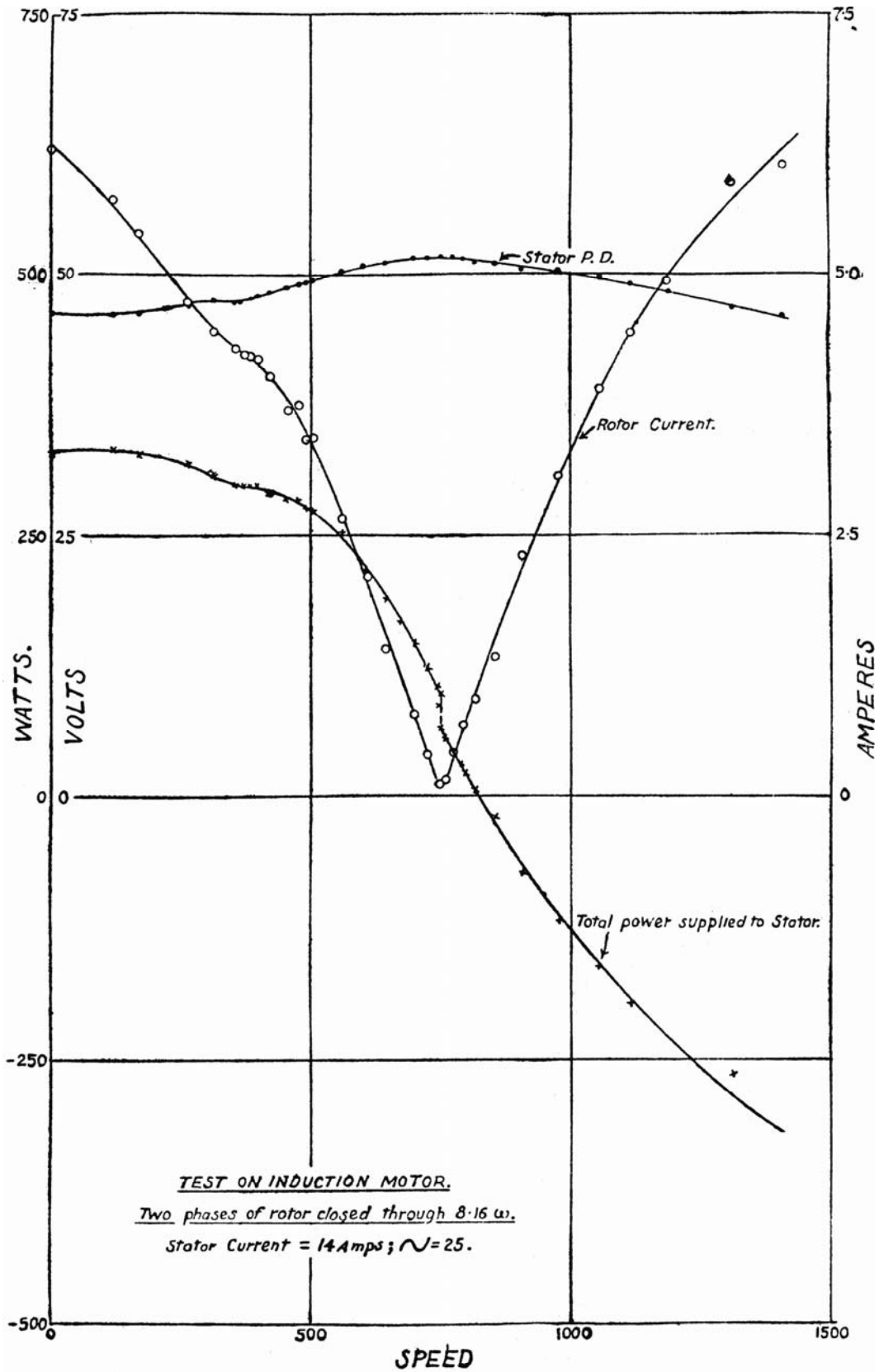

Fig. 12.—Results of induction motor tests with two rotor phases in series closed through external resistance.

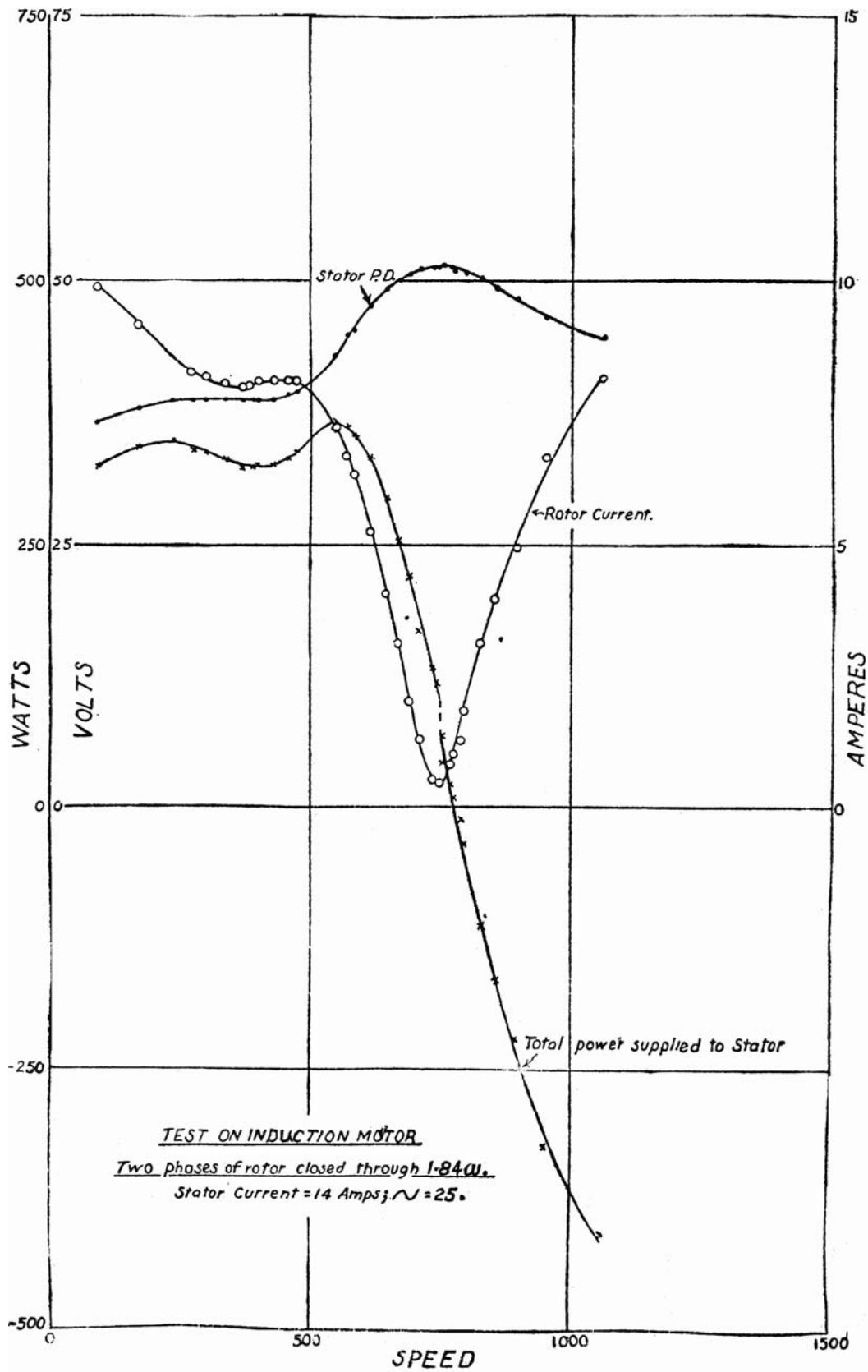

Fig. 13.—Results of induction motor tests with two rotor phases in series closed through external resistance.

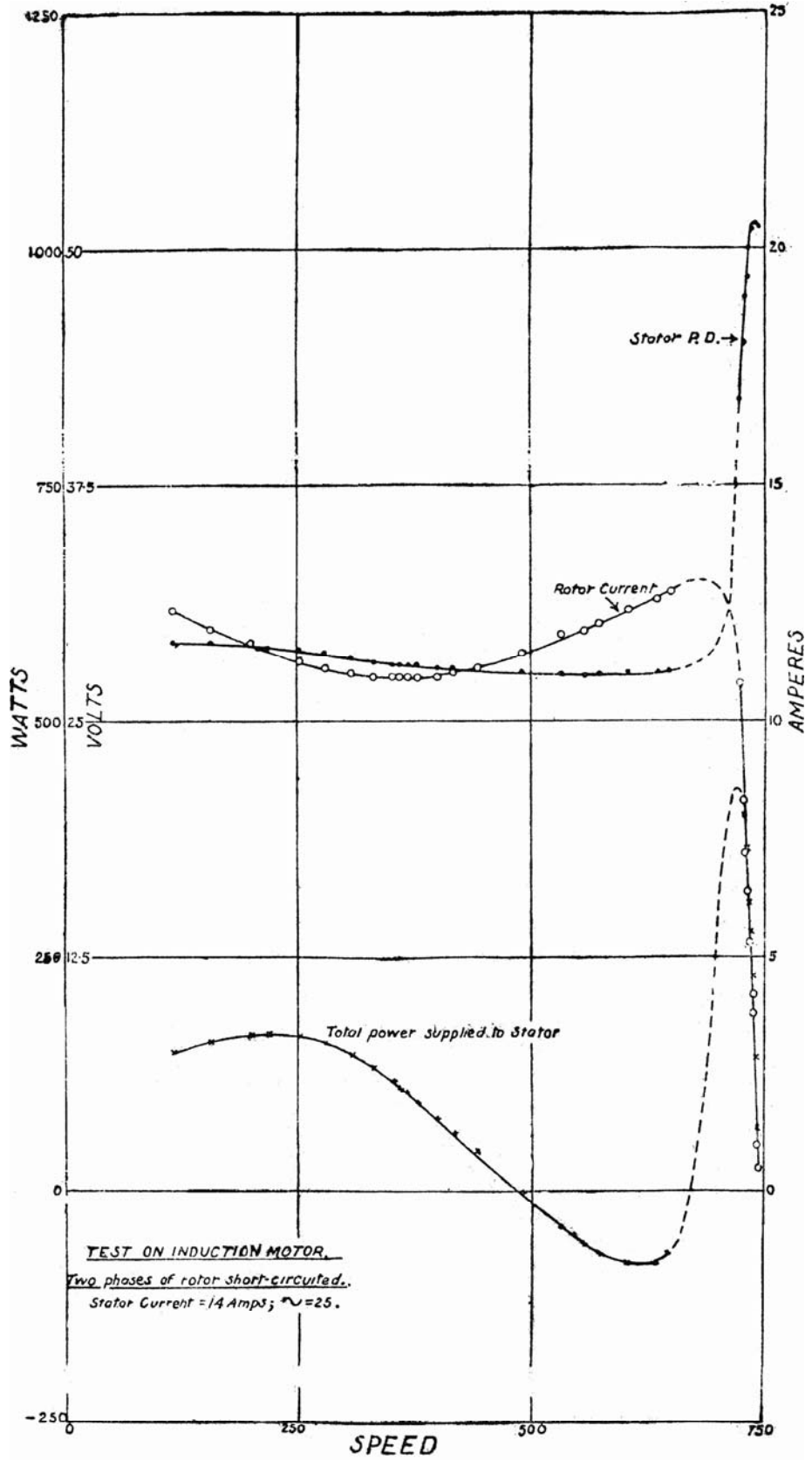

Fig. 14.—Results of induction motor tests with two phases of rotor series short-circuited.

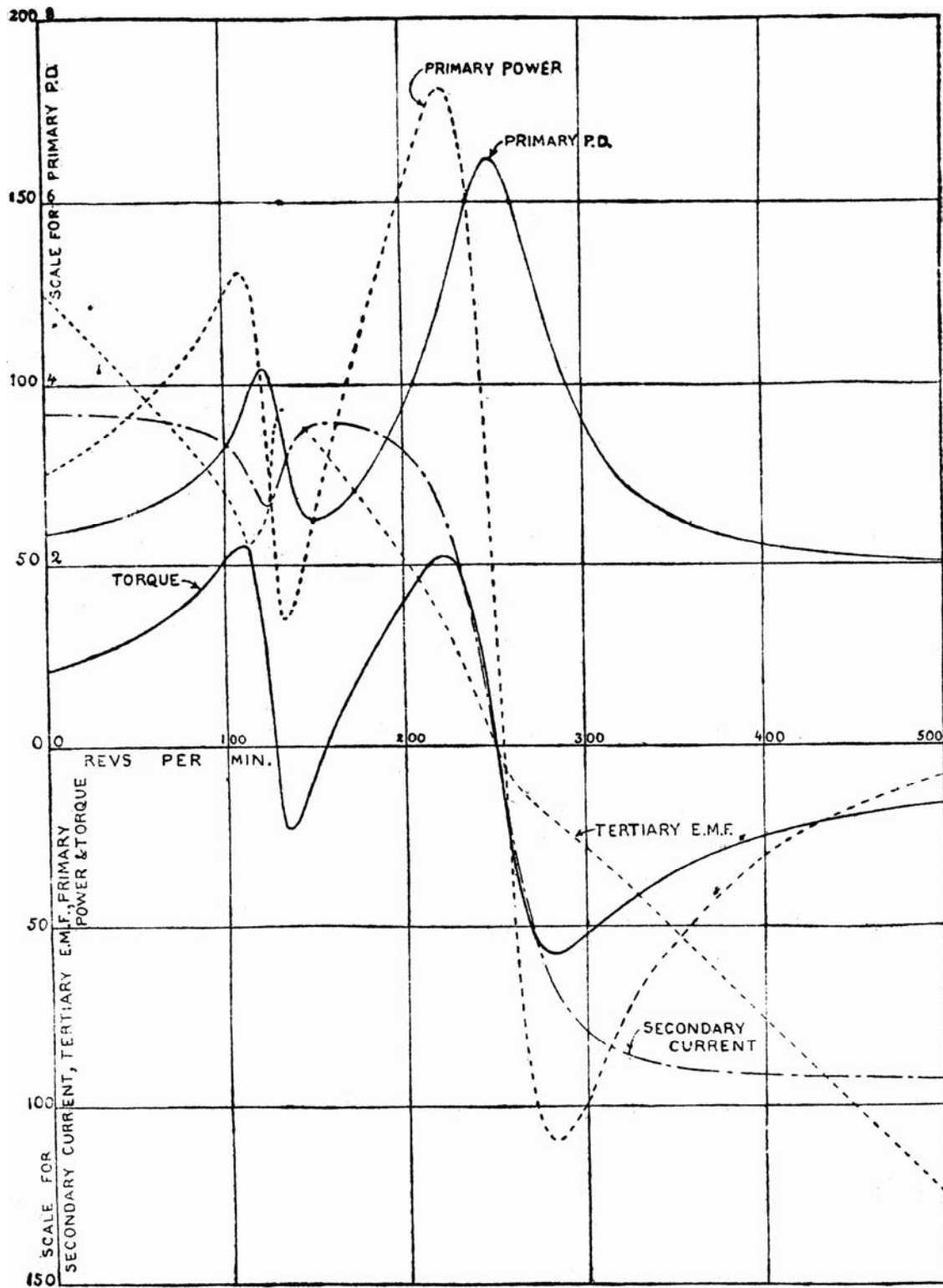

Fig. 15.—Curves connecting primary p. d., primary power, secondary current, tertiary e. m. f. and torque with speed when the primary current is maintained at a constant value.



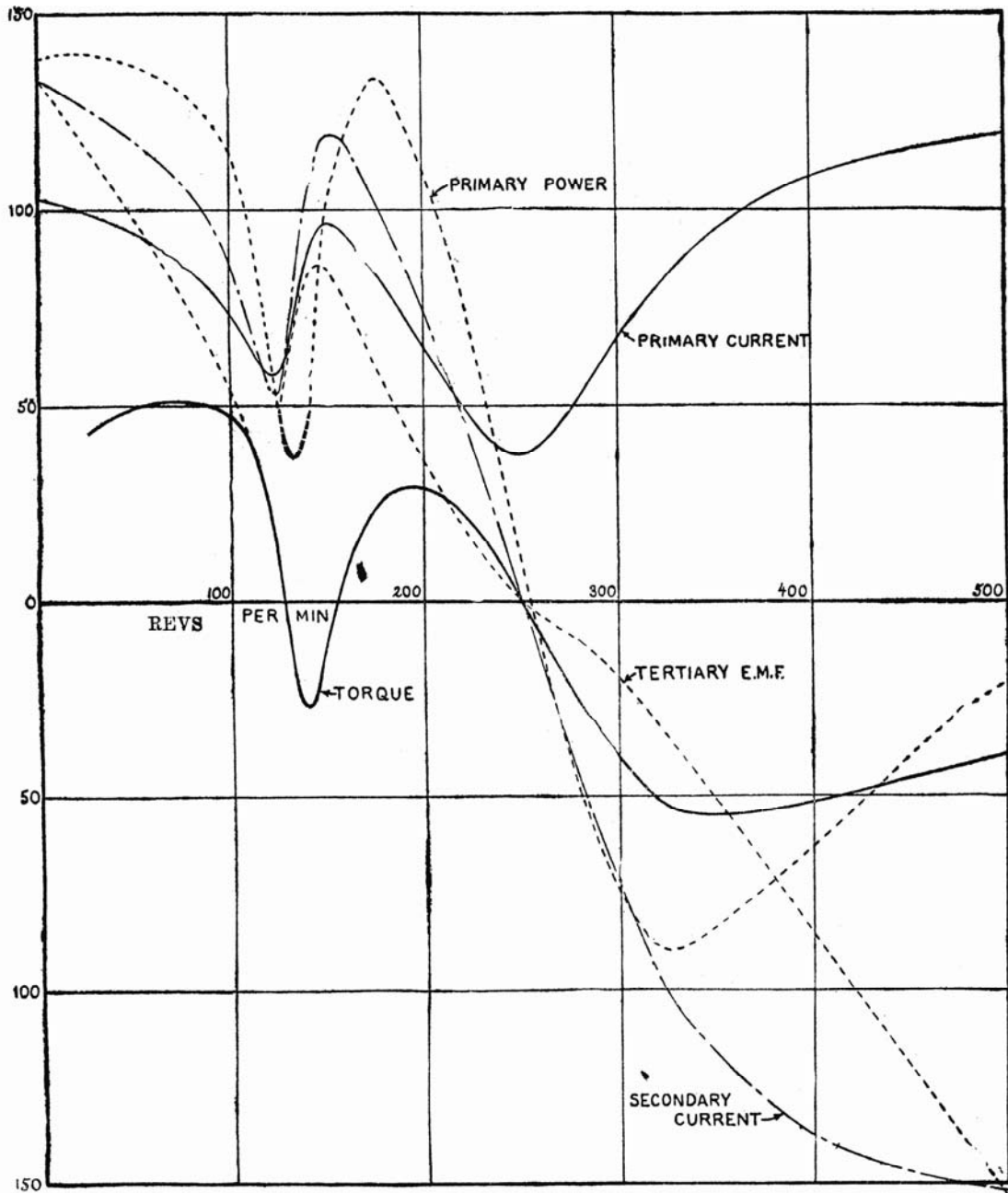

Fig. 16.—Curves connecting primary current, primary power, secondary current, tertiary e. m. f. and torque with speed when the primary p. d. is maintained constant.

For primary current curve, multiply vertical scale readings by	2
„ primary power	10
„ secondary current	3
„ tertiary e. m. f.	4
„ torque	10